

710

DATA BASE FOR LIGHT-WEIGHT
AUTOMOTIVE DIESEL POWER PLANTS
Volume III: Miscellaneous Data

B. Wiedemann, R. Schmidt, et al.
Volkswagenwerk
Research Division
3180 Wolfsburg
Federal Republic of Germany



1979
FINAL REPORT

DOCUMENT IS AVAILABLE TO THE PUBLIC
THROUGH THE NATIONAL TECHNICAL
INFORMATION SERVICE, SPRINGFIELD,
VIRGINIA 22161

Prepared for

U.S. DEPARTMENT OF TRANSPORTATION
NATIONAL HIGHWAY TRAFFIC SAFETY ADMINISTRATION
Office of Passenger Vehicle Research
Washington DC 20590

NOTICE

This document is disseminated under the sponsorship of the Department of Transportation in the interest of information exchange. The United States Government assumes no liability for its contents or use thereof.

NOTICE

The United States Government does not endorse products or manufacturers. Trade or manufacturer's names appear herein solely because they are considered essential to the object of this report.

NOTICE

The views and conclusions contained in the document are those of the author(s) and should not be interpreted as necessarily representing the official policies or opinions, either expressed or implied, of the Department of Transportation.

1. Report No. DOT-HS-805 278		2. Government Accession No.		3. Recipient's Catalog No.	
4. Title and Subtitle DATA BASE FOR LIGHT-WEIGHT AUTOMOTIVE DIESEL POWER PLANTS, Volume III: Miscellaneous Data				5. Report Date December 1979	
				6. Performing Organization Code	
7. Author(s) B. Wiedemann, R. Schmidt, et al.				8. Performing Organization Report No. DOT-TSC-NHTSA-79-62.III	
9. Performing Organization Name and Address Volkswagenwerk* Research Division 3180 Wolfsburg Federal Republic of Germany				10. Work Unit No. (TRAIS) HS017/R0411	
				11. Contract or Grant No. DOT/TSC-1193	
12. Sponsoring Agency Name and Address U.S. Department of Transportation National Highway Traffic Safety Administration Office of Passenger Vehicle Research Washington DC 20590				13. Type of Report and Period Covered Final Report June 30 '76-July 30 '77	
				14. Sponsoring Agency Code	
15. Supplementary Notes *Under contract to:		U.S. Department of Transportation Research and Special Programs Administration Transportation Systems Center Cambridge MA 02142			
16. Abstract <p>The effects of fuel economy, emissions, passenger car safety and other variables due to the installation of light-weight Diesel powerplants were studied. Experimental data was obtained on naturally aspirated and turbocharged Diesel engines installed in subcompact and compact passenger vehicles. The data includes fuel economy as a function of engine type and horsepower, as a function of vehicle inertia weight and as a function of regulated emission constraints. Unregulated emissions have been characterized during the course of the work. The compatibility of the Diesel engine studied with passenger car structures incorporating advanced frontal crashworthiness capabilities was also verified.</p> <p>The report consists of three volumes. Volume I, the Executive Summary, presents a summary of the data obtained and a review of the important conclusions. Volume II, the main body of the report, provides a discussion of the fuel economy and emissions obtained, a description of the engine/vehicle systems tested and the results of factory driveability tests. Volume III, the appendixes, presents miscellaenous data used during the program.</p>					
17. Key Words Diesels, CI-Engines, Passenger Cars, Fuel economy, Safety, Emissions, Automobiles			18. Distribution Statement DOCUMENT IS AVAILABLE TO THE PUBLIC THROUGH THE NATIONAL TECHNICAL INFORMATION SERVICE, SPRINGFIELD, VIRGINIA 22161		
19. Security Classif. (of this report) Unclassified		20. Security Classif. (of this page) Unclassified		21. No. of Pages 206	22. Price

PREFACE

In support of the National Highway Traffic Safety Administration, Office of Passenger Vehicle Research, the Department of Transportation-Transportation Systems Center contracted with Volkswagenwerk AG, Federal Republic of Germany to develop a data base on light-weight Diesel engines suitable for passenger cars. Volkswagen research, pre-production and production Diesel engines were used for the test portion of the work and for the 'analytical extrapolation.'

A Volkswagen research vehicle with advanced crashworthiness characteristics was provided by Volkswagen to demonstrate and document compatibility with an advanced diesel engine design (Integrated Research Vehicle). Through the effort the Diesel engines were evaluated in the context of an integrated vehicle system with the aspects of fuel economy, environment, consumer requirements and cost in mind.

The authors wish to acknowledge the guidance provided by Mr. H.Gould and Dr.R.John of the Department of Transportation-Transportation Systems Center and Dr. K. Digges of the Department of Transportation-National Highway Traffic Safety Administration.

Our working team consisted of the following persons:

Miss C. Schwarz, Messrs. R. Graupmann, W. Lange, K.-J. Lemke, H. Leptien, Dr. G. W. Schweimer and M. Willmann.

They were supported by:

Miss J. Dommschack and Messrs. H.-D. Beckmann, P. M. Deja, P. Jirousek, W. Kiegeland, W. Kurpiers, Dr. K.-H. Lies, J. Nitz, E. Pommer, K.-H. Schneider and P. Seifert together with members of the staff from the VW prototype shop, the VW transmission development department and the VW measuring and testing department.

METRIC CONVERSION FACTORS

Approximate Conversions to Metric Measures

Symbol	When You Know	Multiply by	To Find	Symbol
LENGTH				
in	inches	*2.5	centimeters	cm
ft	feet	30	centimeters	cm
yd	yards	0.9	meters	m
mi	miles	1.6	kilometers	km
AREA				
in ²	square inches	6.5	square centimeters	cm ²
ft ²	square feet	0.09	square meters	m ²
yd ²	square yards	0.8	square meters	m ²
mi ²	square miles	2.6	square kilometers	km ²
	acres	0.4	hectares	ha
MASS (weight)				
oz	ounces	28	grams	g
lb	pounds	0.45	kilograms	kg
	short tons (2000 lb)	0.9	tonnes	t
VOLUME				
tsp	teaspoons	5	milliliters	ml
Tbsp	tablespoons	15	milliliters	ml
fl oz	fluid ounces	30	milliliters	ml
c	cups	0.24	liters	l
pt	pints	0.47	liters	l
qt	quarts	0.95	liters	l
gal	gallons	3.8	liters	l
ft ³	cubic feet	0.03	cubic meters	m ³
yd ³	cubic yards	0.76	cubic meters	m ³
TEMPERATURE (exact)				
°F	Fahrenheit temperature	5/9 (after subtracting 32)	Celsius temperature	°C

* 1 in = 2.54 (exactly). For other exact conversions and more detailed tables, see NBS Misc. Publ. 286, Units of Weights and Measures, Price \$2.25, SD Catalog No. C13.10 286.

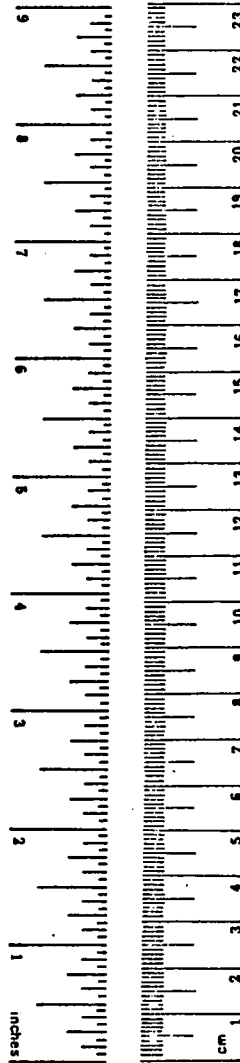

Approximate Conversions from Metric Measures

Symbol	When You Know	Multiply by	To Find	Symbol
LENGTH				
mm	millimeters	0.04	inches	in
cm	centimeters	0.4	inches	in
m	meters	3.3	feet	ft
m	meters	1.1	yards	yd
km	kilometers	0.6	miles	mi
AREA				
cm ²	square centimeters	0.16	square inches	in ²
m ²	square meters	1.2	square yards	yd ²
km ²	square kilometers	0.4	square miles	mi ²
ha	hectares (10,000 m ²)	2.6	acres	
MASS (weight)				
g	grams	0.035	ounces	oz
kg	kilograms	2.2	pounds	lb
t	tonnes (1000 kg)	1.1	short tons	
VOLUME				
ml	milliliters	0.03	fluid ounces	fl oz
l	liters	2.1	pints	pt
l	liters	1.06	quarts	qt
l	liters	0.26	gallons	gal
m ³	cubic meters	35	cubic feet	ft ³
m ³	cubic meters	1.3	cubic yards	yd ³
TEMPERATURE (exact)				
°C	Celsius temperature	9/5 (then add 32)	Fahrenheit temperature	°F

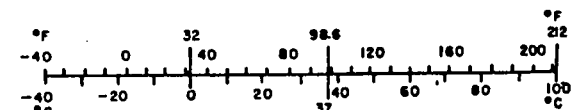
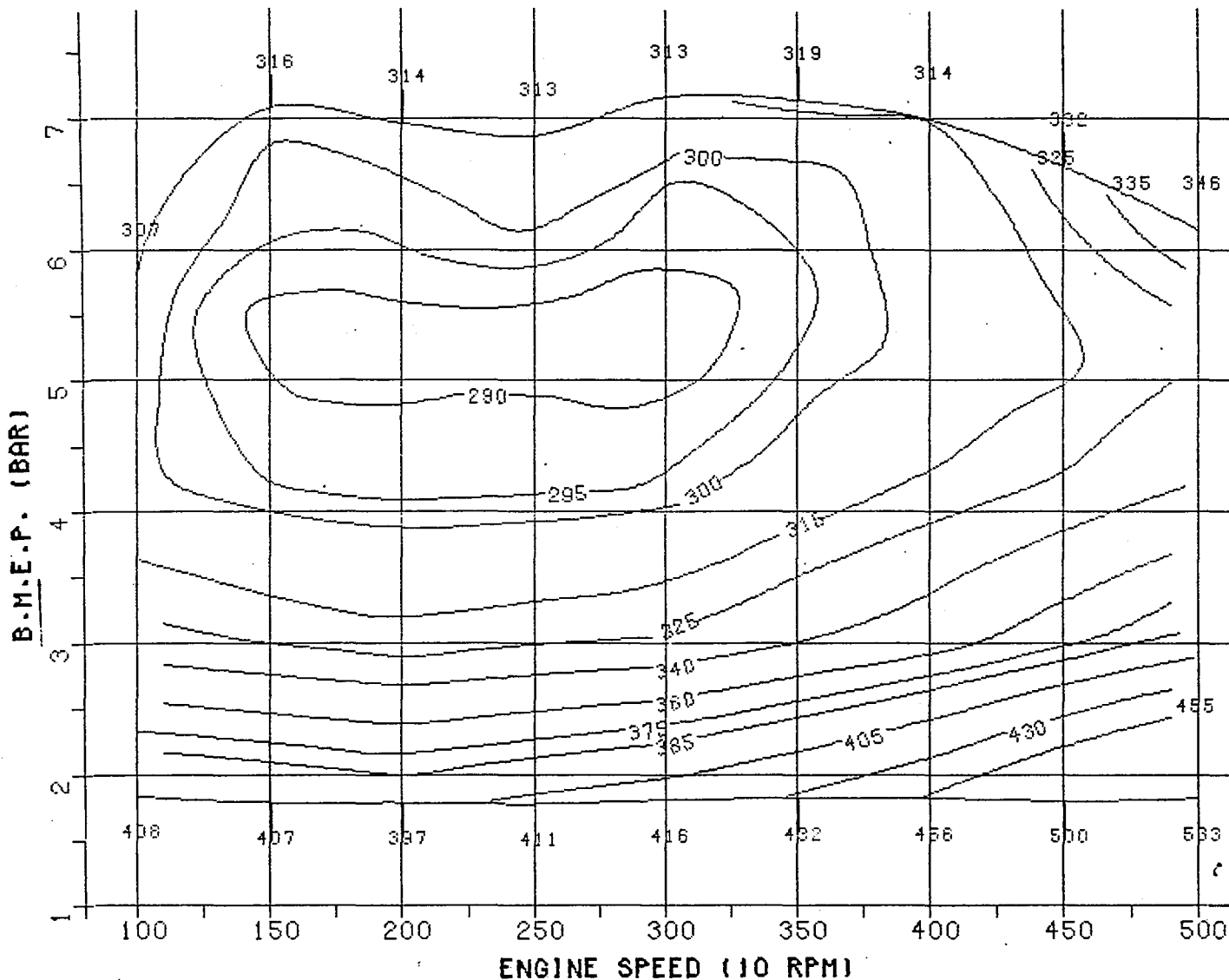

TABLE OF CONTENTS

<u>Section</u>	<u>Page</u>
APPENDIX A - MISCELLANEOUS DATA.....	1
APPENDIX B - REPORT OF NEW TECHNOLOGY.....	201

APPENDIX A
MISCELLANEOUS DATA



SPECIFIC FUEL CONSUMPTION (G/KWH)
 50 HP N.A. 90 CID PRODUCTION DIESEL ENGINE

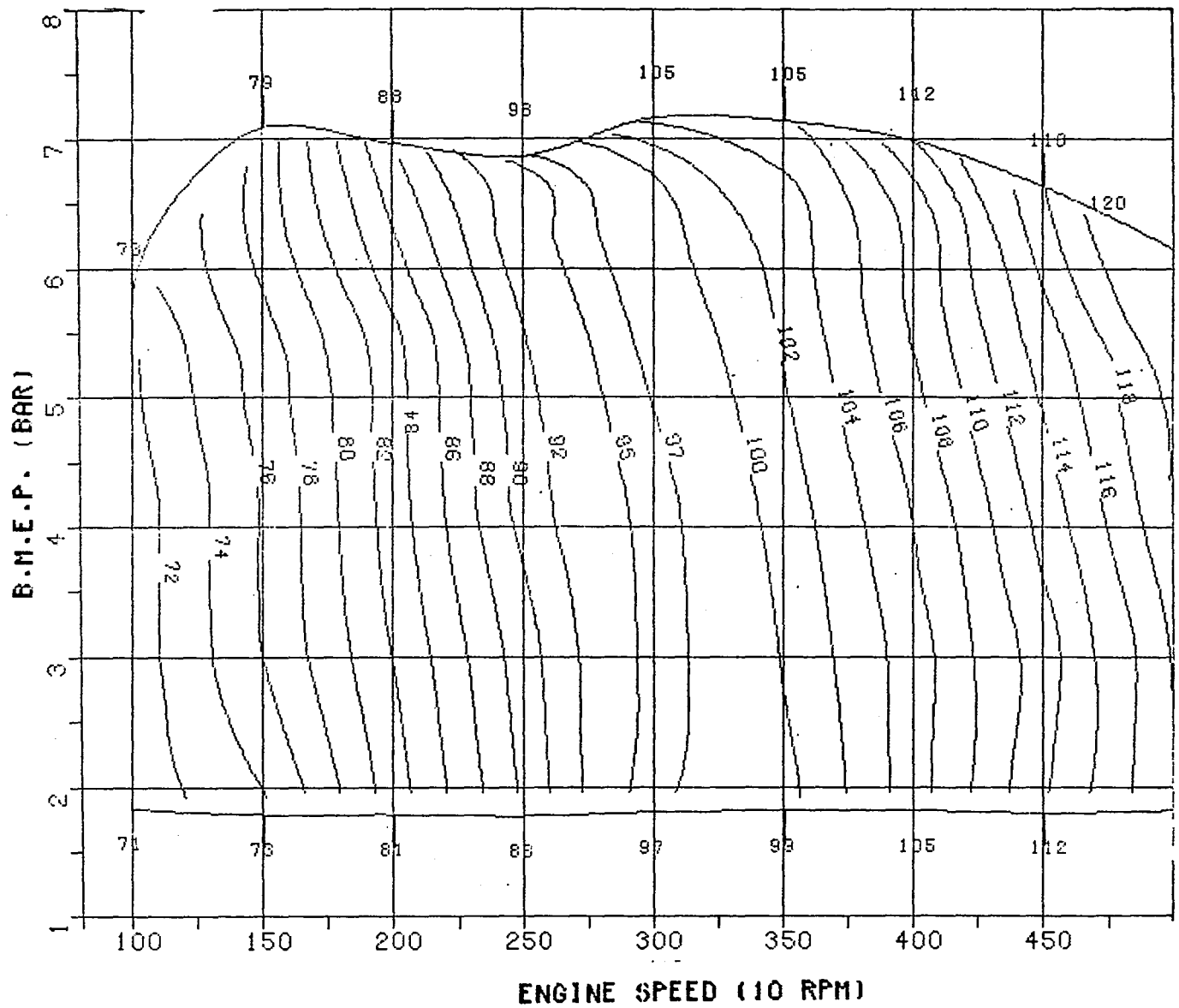

OIL TEMPERATURE (CELSIUS)
 50 HP N.A. 90 CID PRODUCTION DIESEL ENGINE

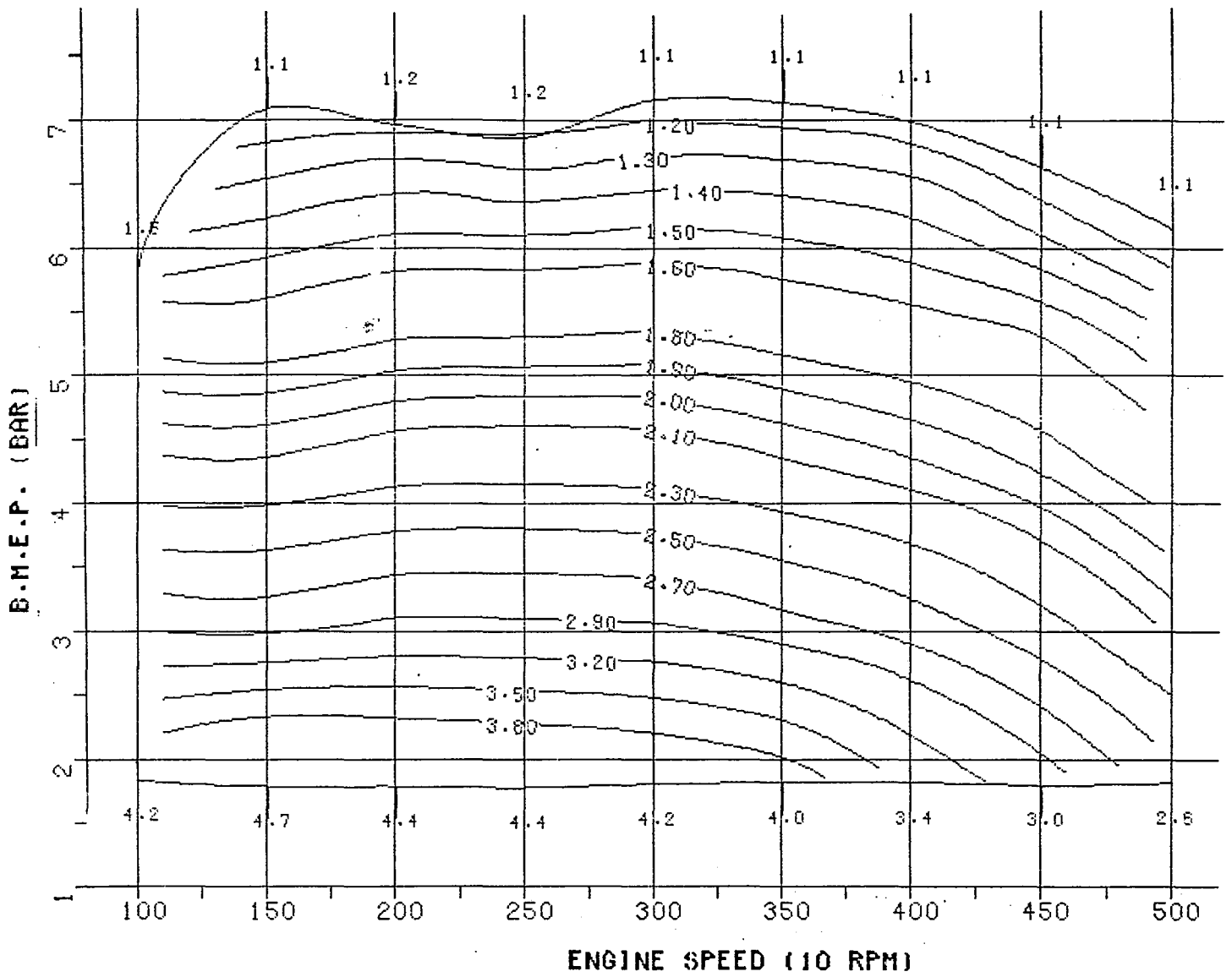

AIR TO FUEL RATIO
 50 HP N.A. 90 CID PRODUCTION DIESEL ENGINE

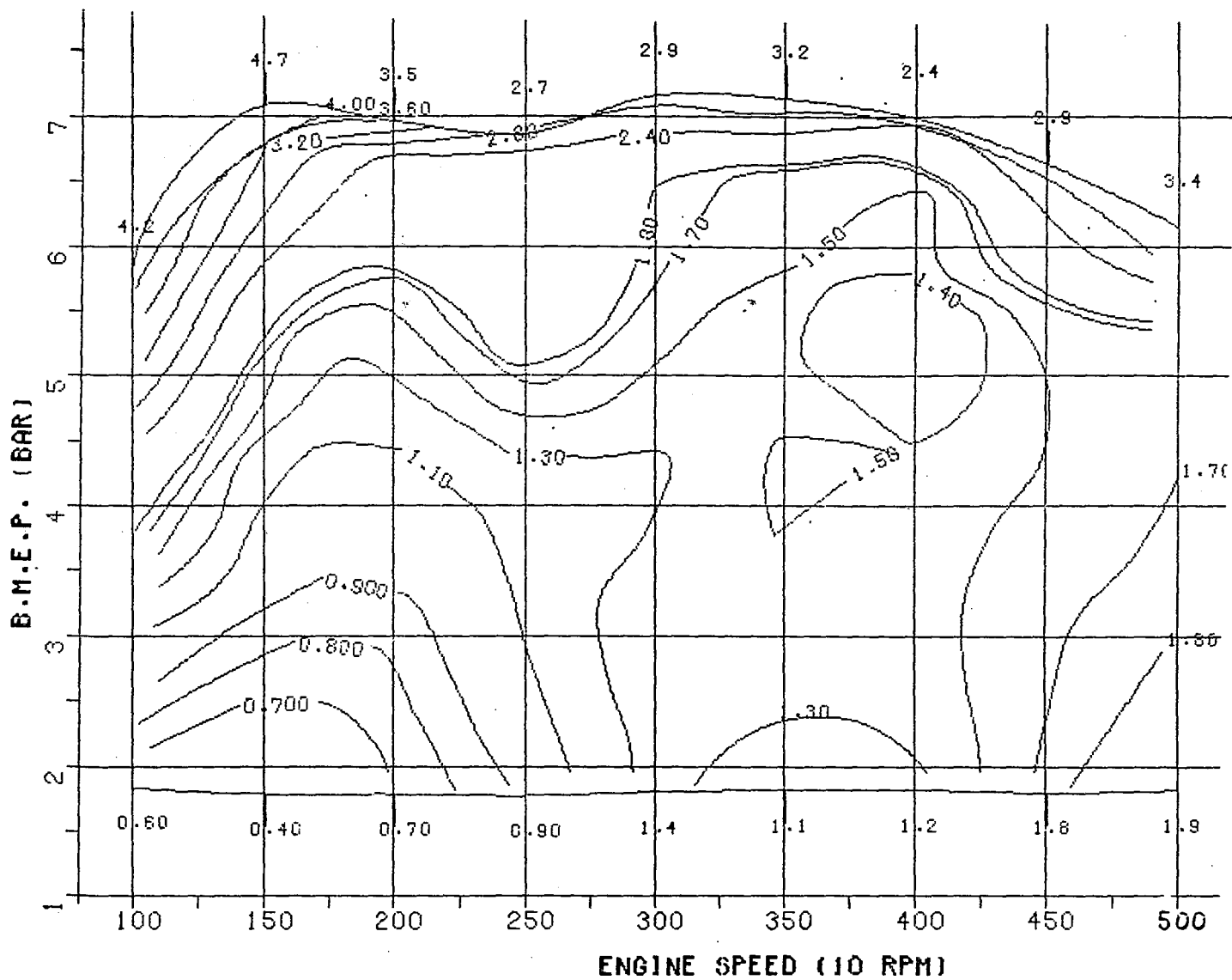

SMOKE (BOSCH NUMBER)
 50 HP N.A. 90 CID PRODUCTION DIESEL ENGINE

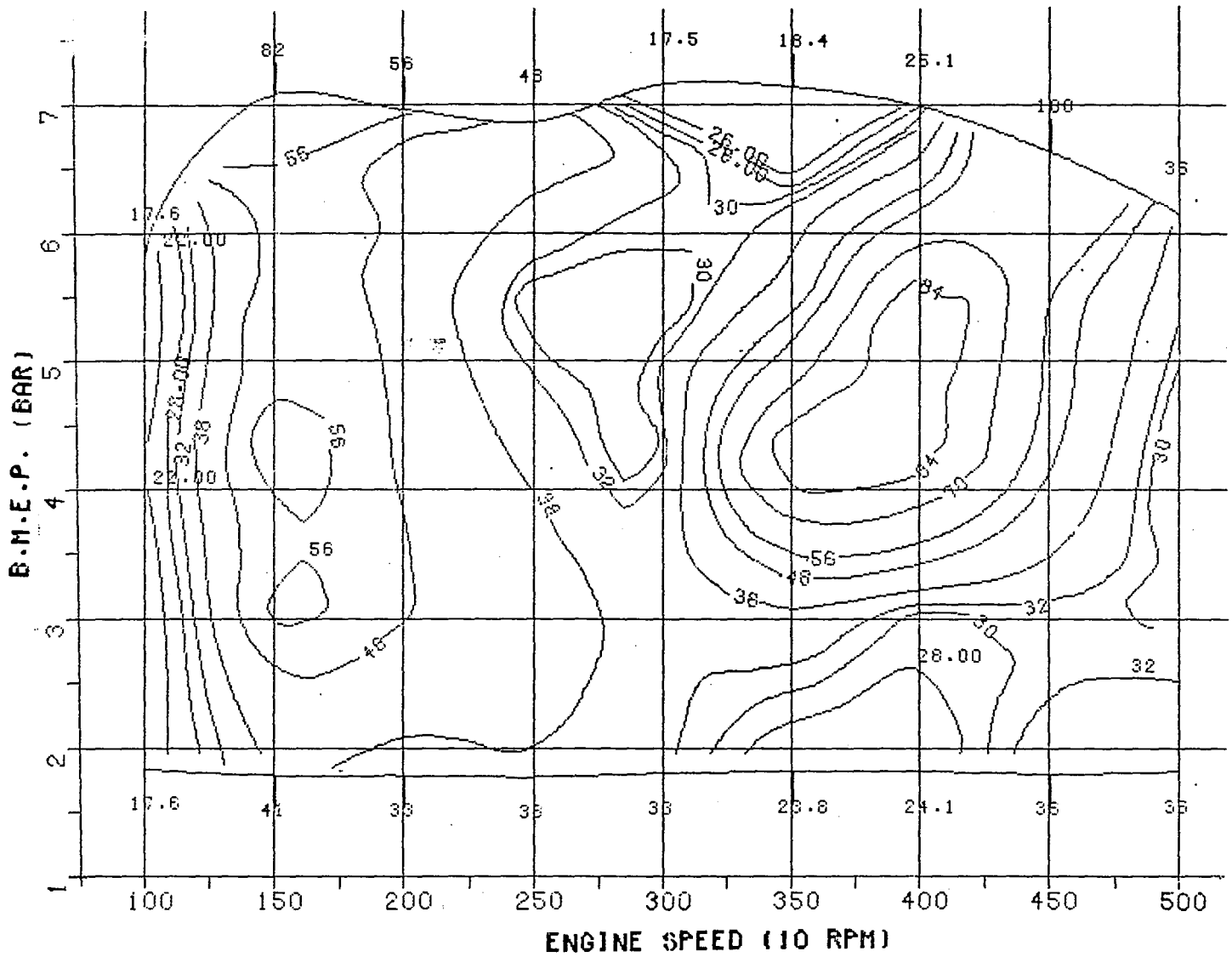

HC CONCENTRATION (PPM)
 50 HP N.A. 90 CID PRODUCTION DIESEL ENGINE

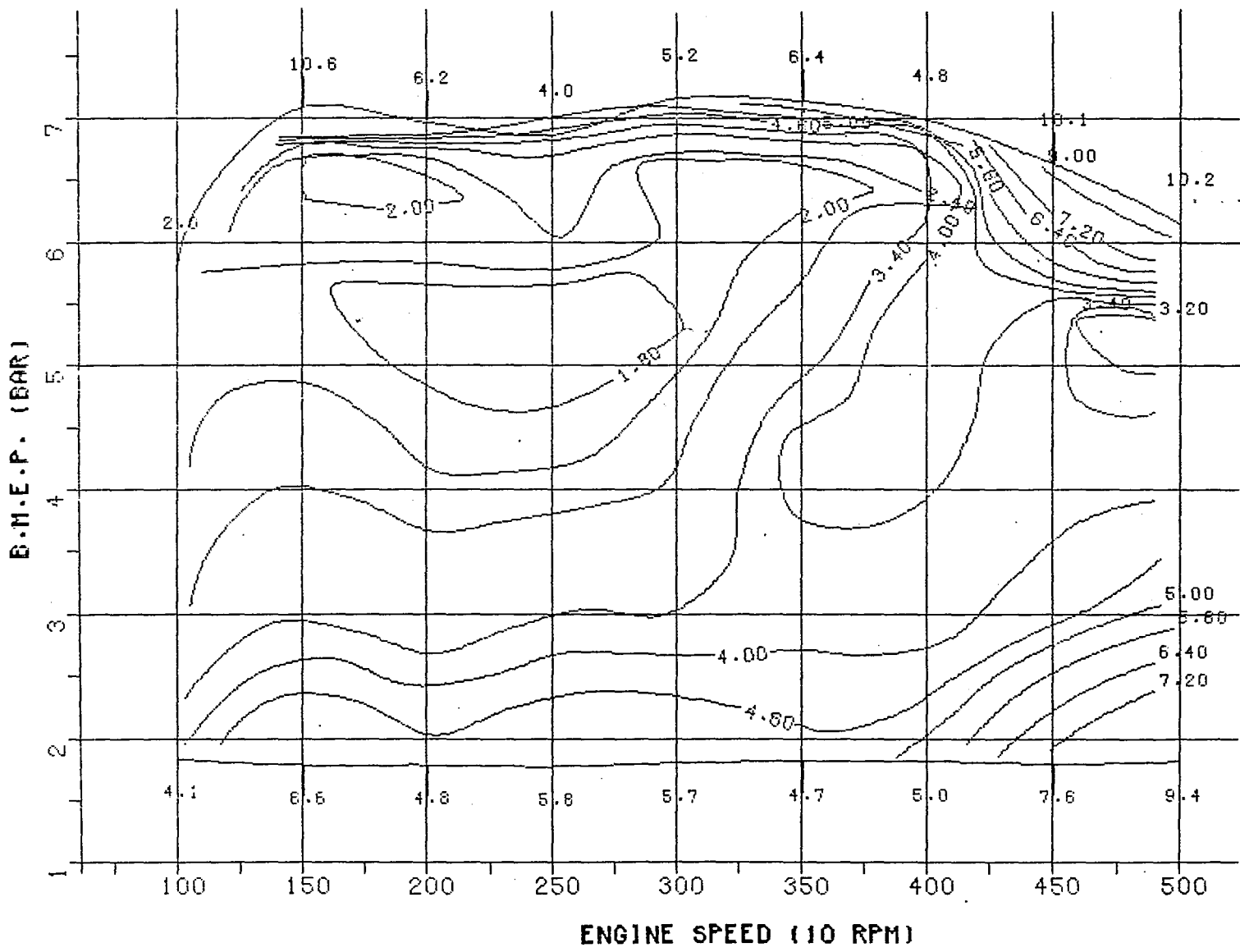

CO EMISSION (G/KWH)
 50 HP N.A. 90 CID PRODUCTION DIESEL ENGINE

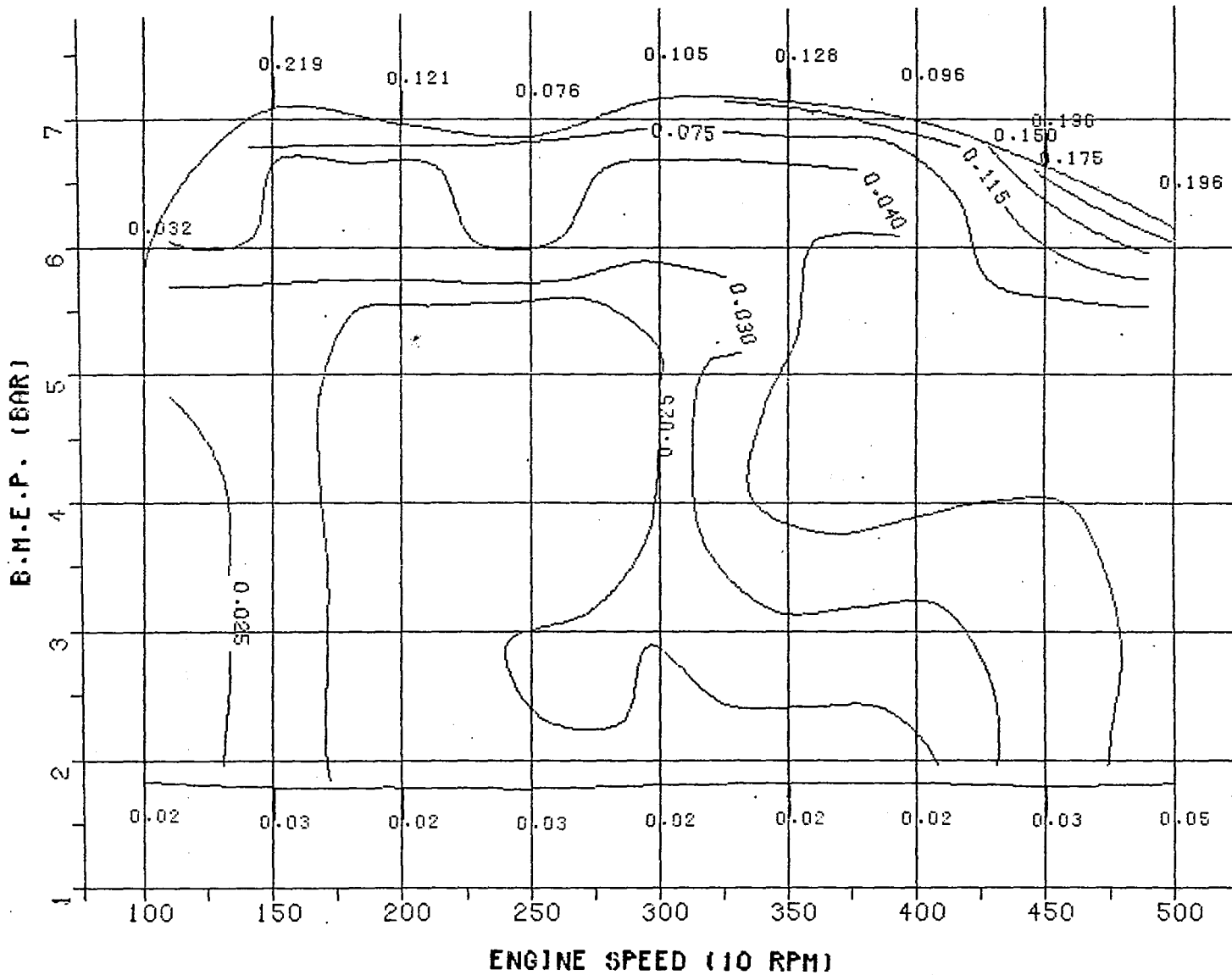

CO CONCENTRATION (%)
 50 HP N.A. 90 CID PRODUCTION DIESEL ENGINE

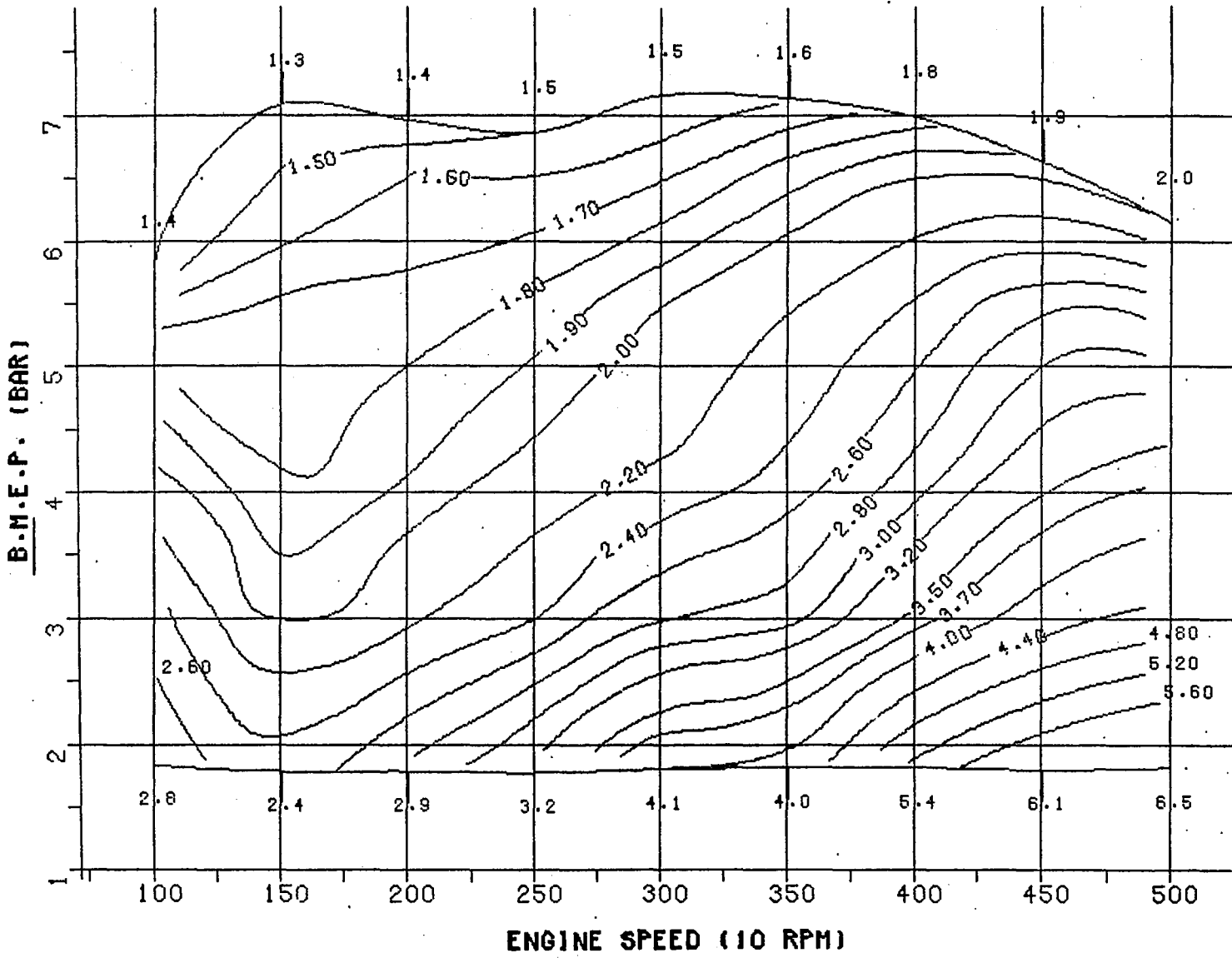

NO EMISSION (G/KWH)
 50 HP N.A. 90 CID PRODUCTION DIESEL ENGINE

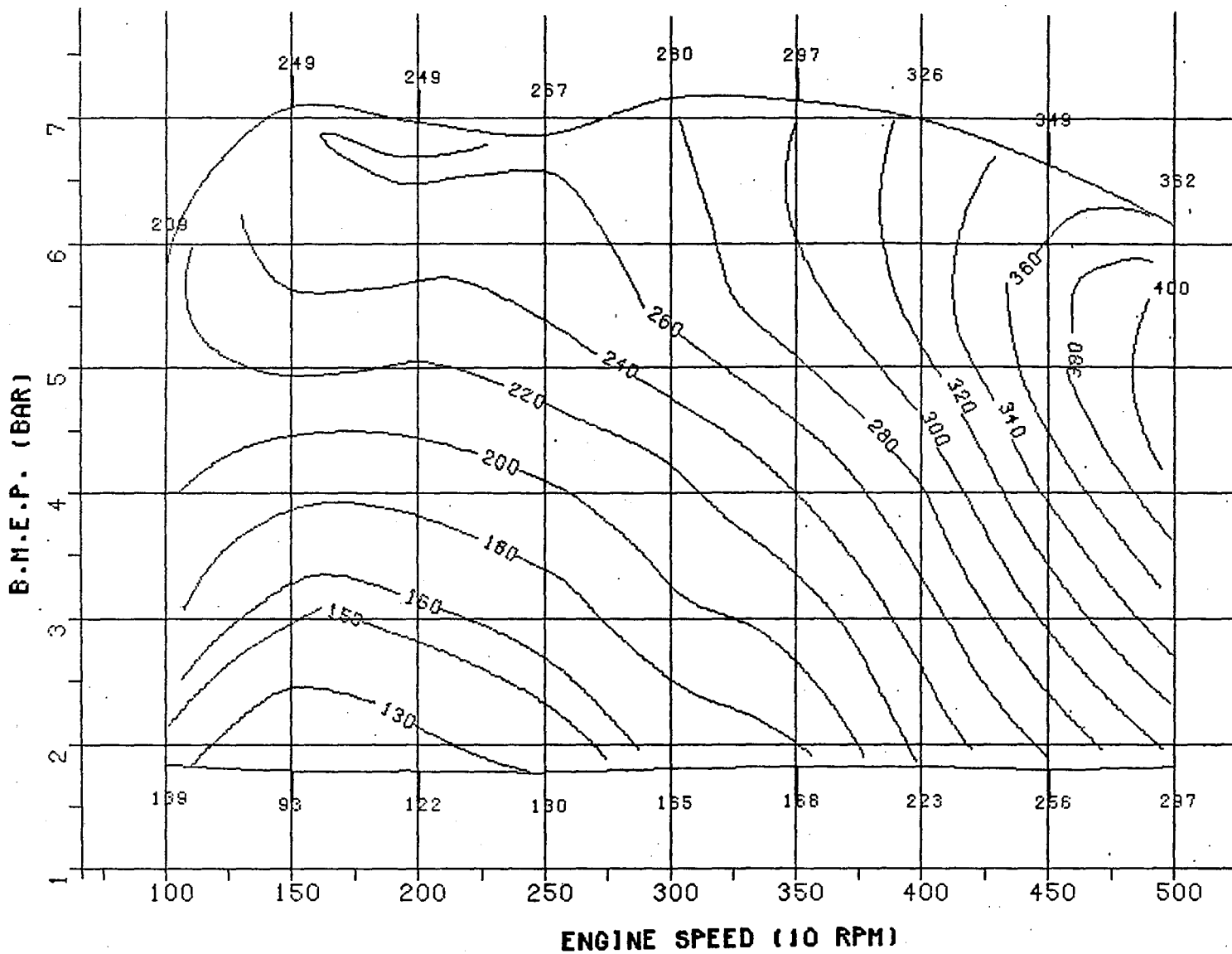

NO CONCENTRATION (PPM)
 50 HP N.A. 90 CID PRODUCTION DIESEL ENGINE

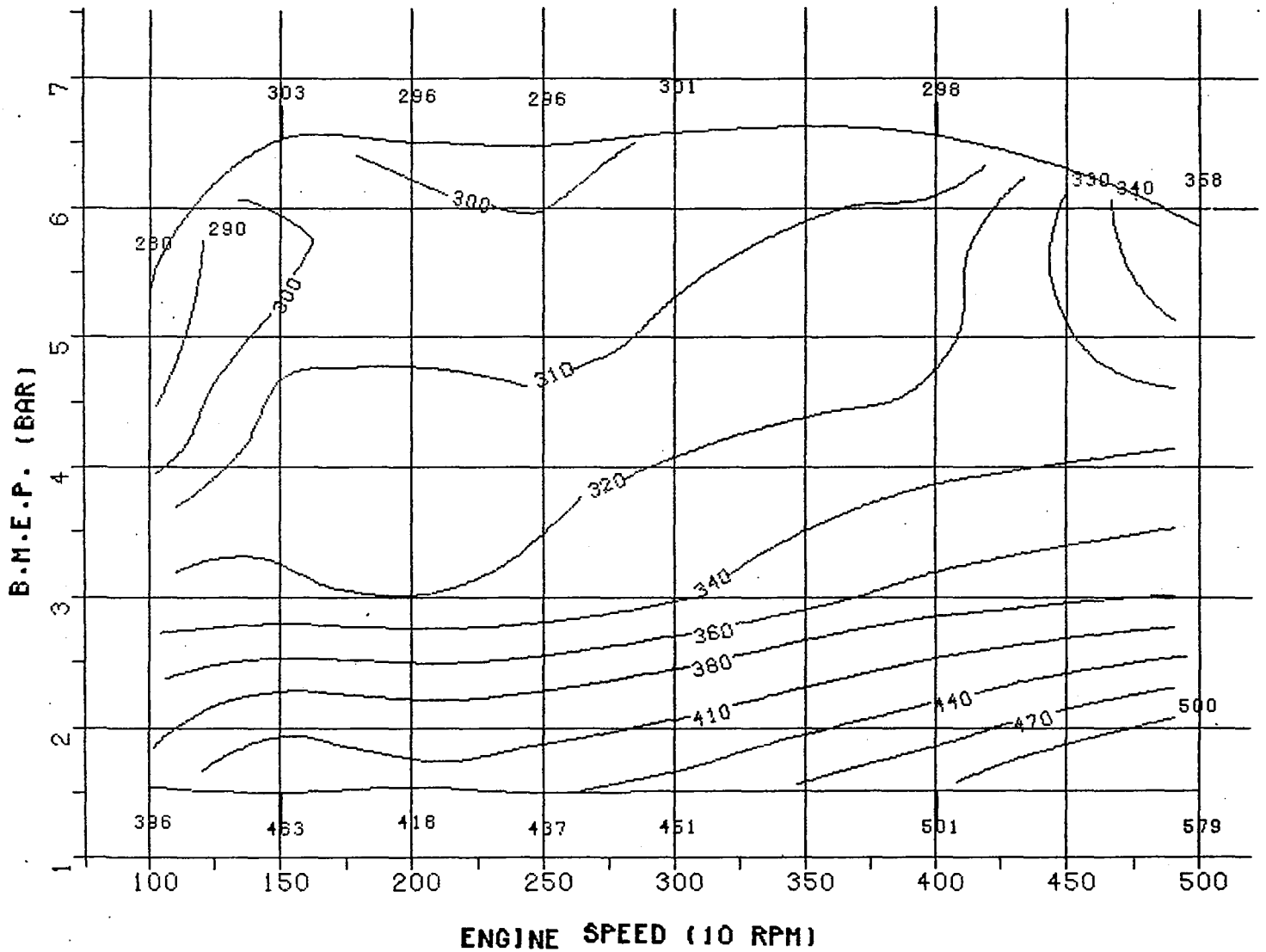

SPECIFIC FUEL CONSUMPTION (G/KWH)
 50 HP N.A. DIESEL ENGINE WITH MODULATED E.G.R.

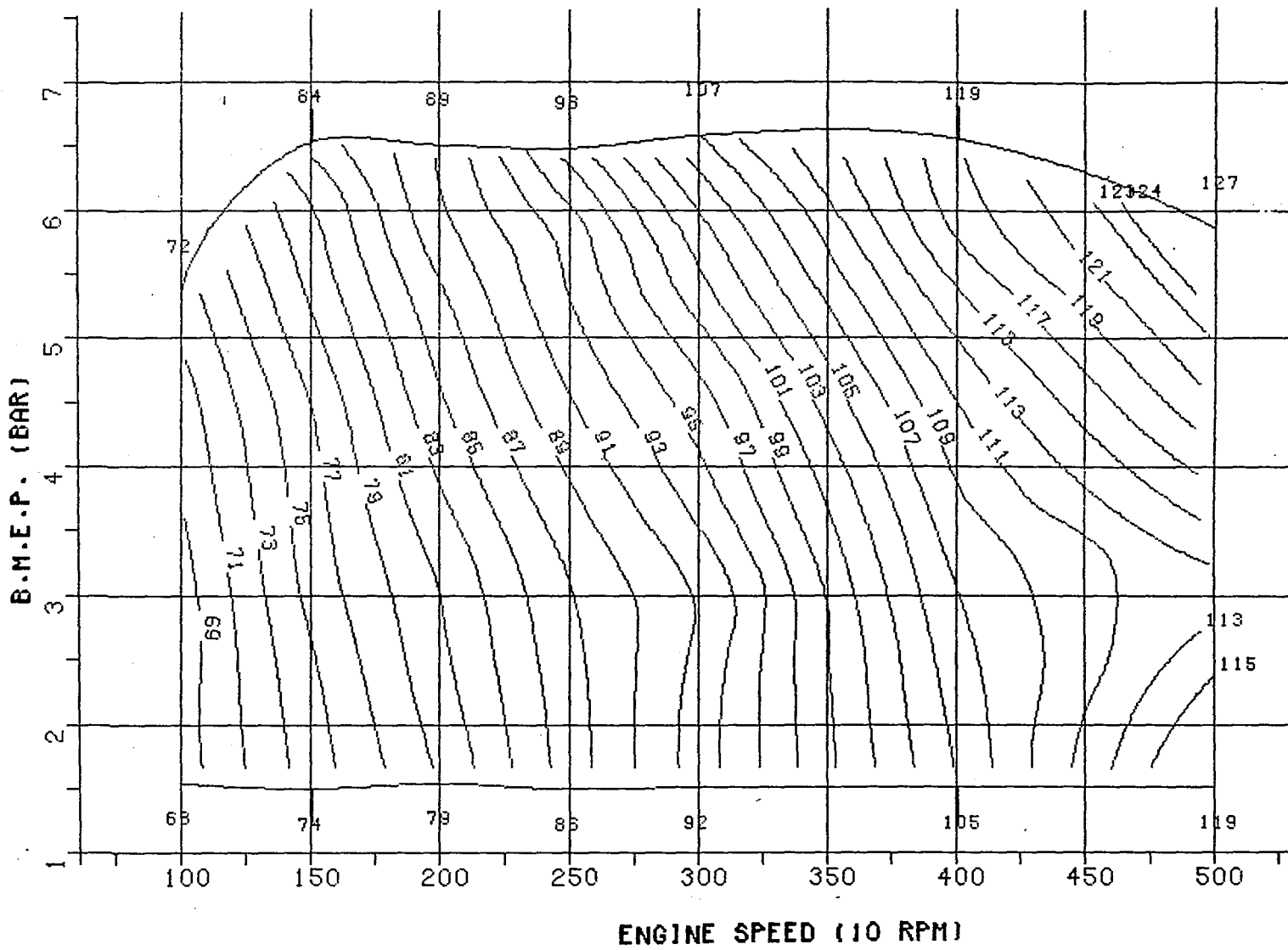

OIL TEMPERATURE (CELSIUS)
 50 HP N.A. DIESEL ENGINE WITH MODULATED E.G.R.

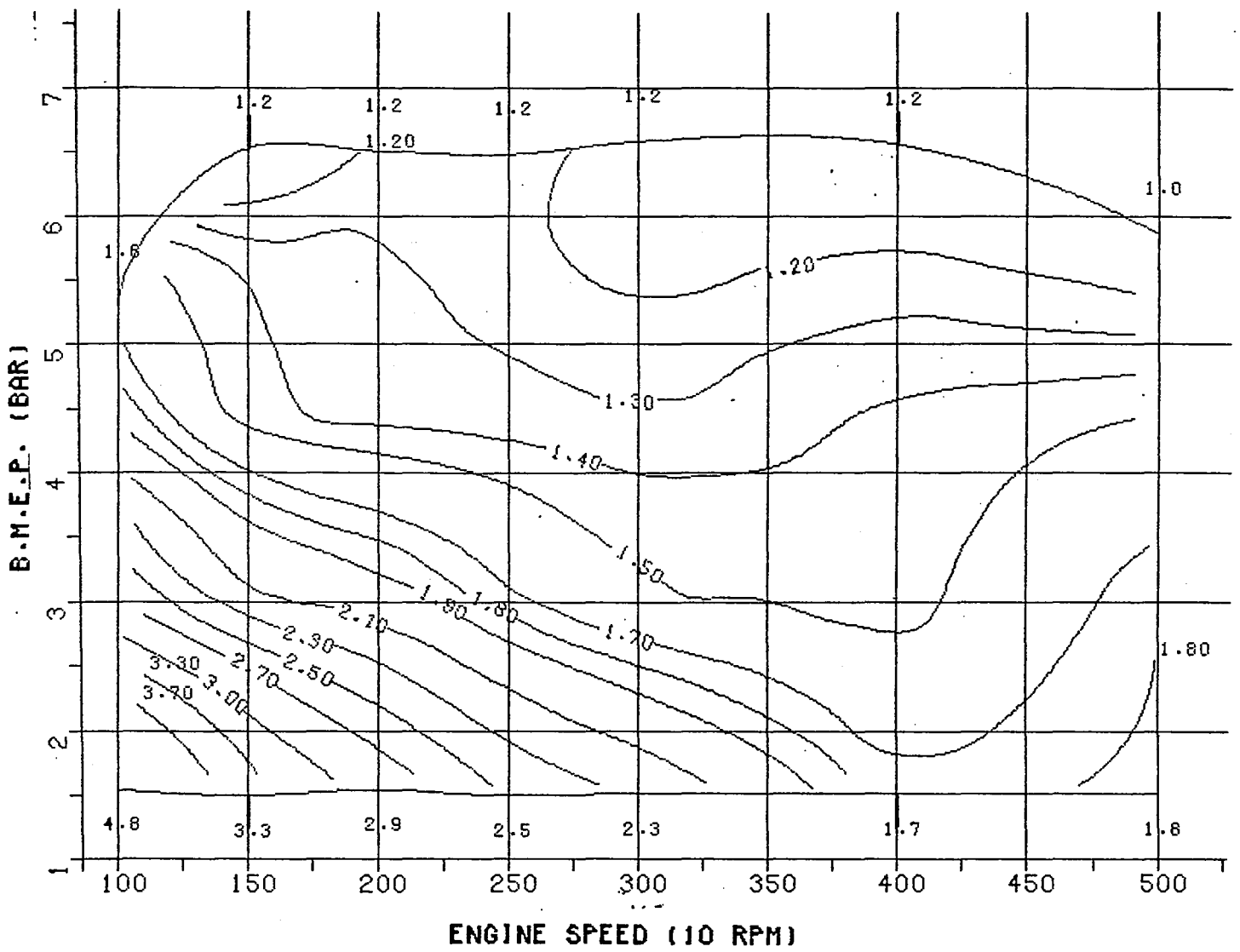

AIR TO FUEL RATIO
 50 HP N.A. DIESEL ENGINE WITH MODULATED E.G.R.

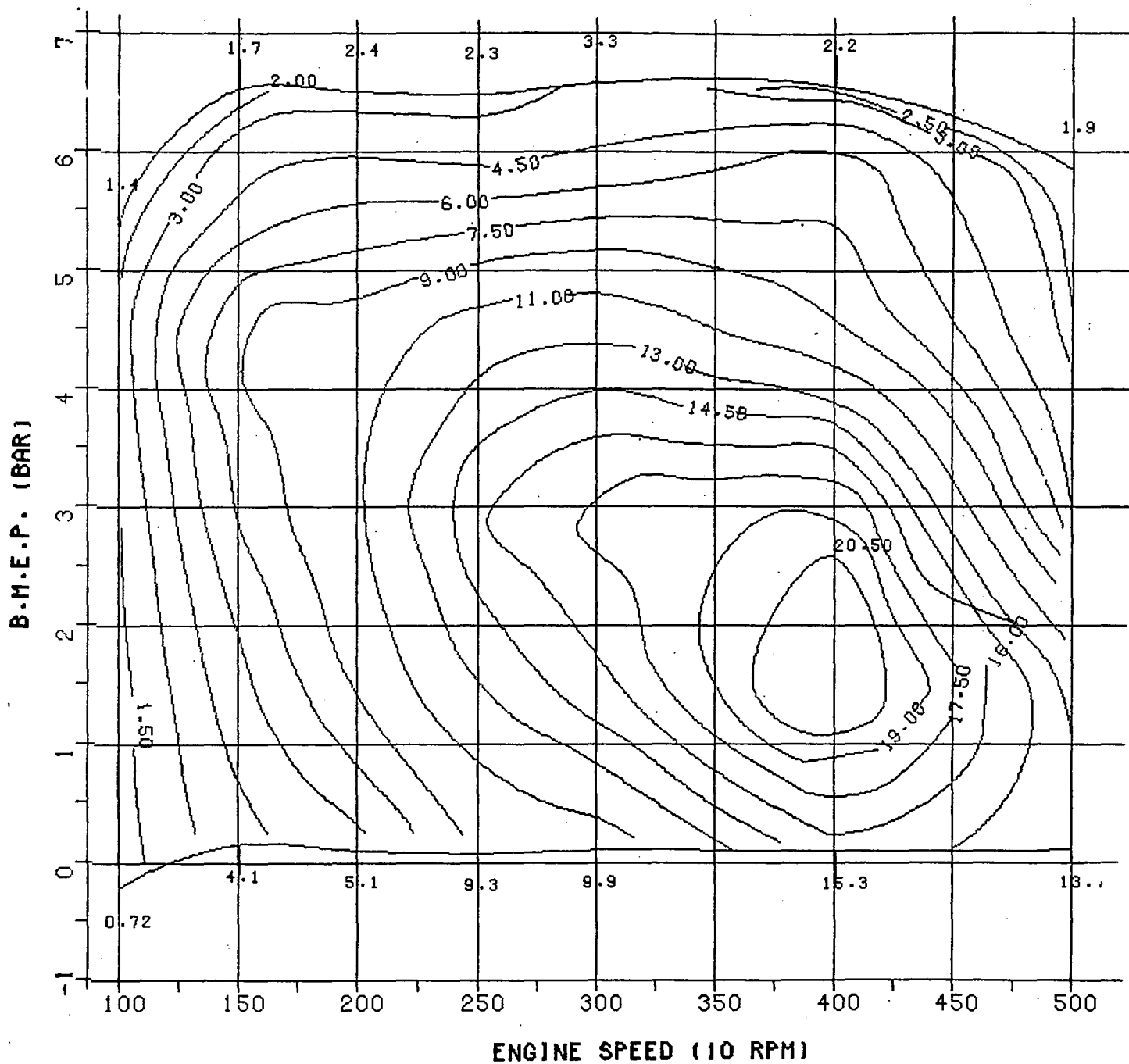

EFFECTIVE E.G.R. (%)
 50 HP N.A. DIESEL ENGINE WITH MODULATED E.G.R.

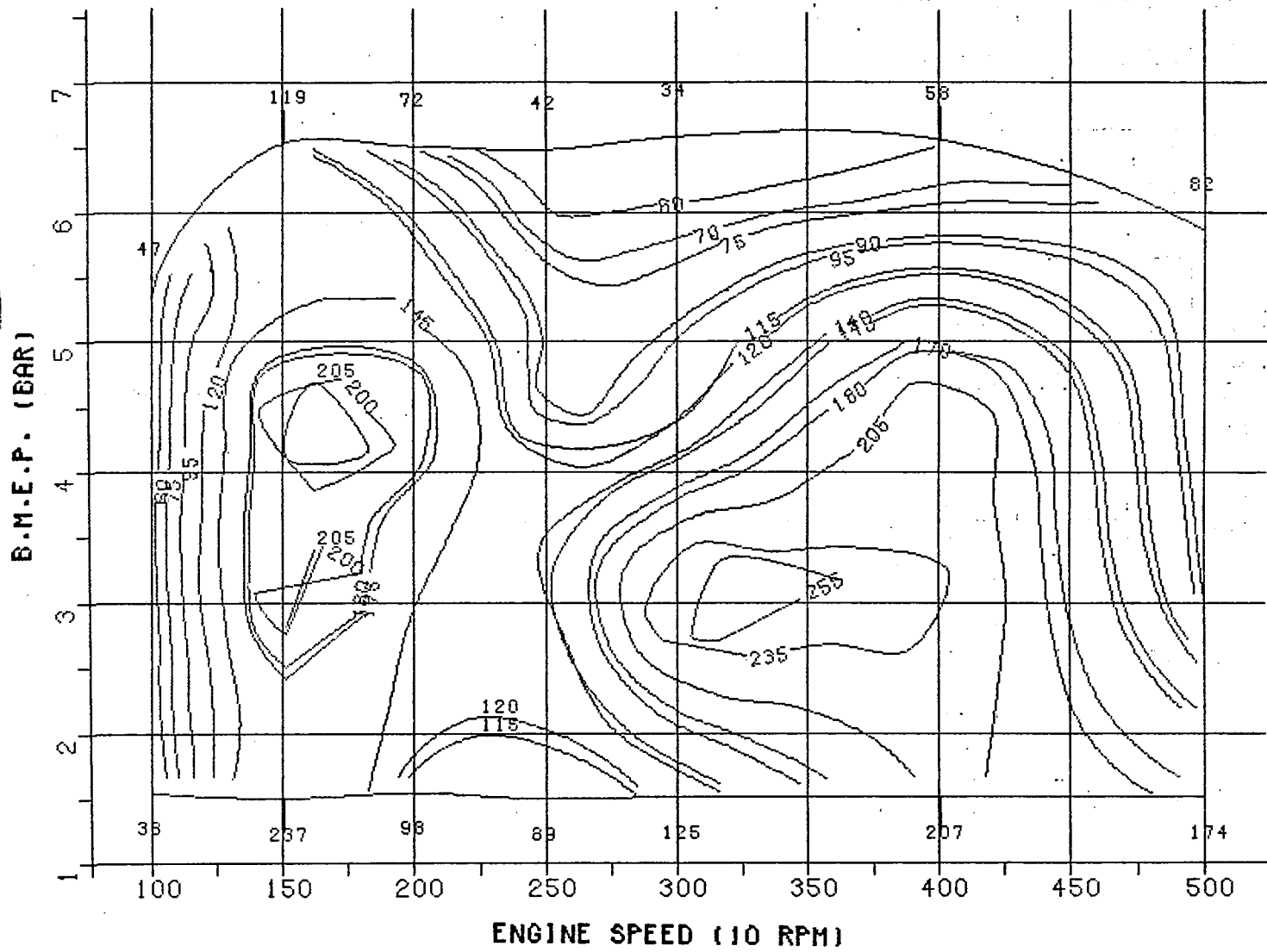

HC CONCENTRATION (PPM)
 50 HP N.A. DIESEL ENGINE WITH MODULATED E.G.R.

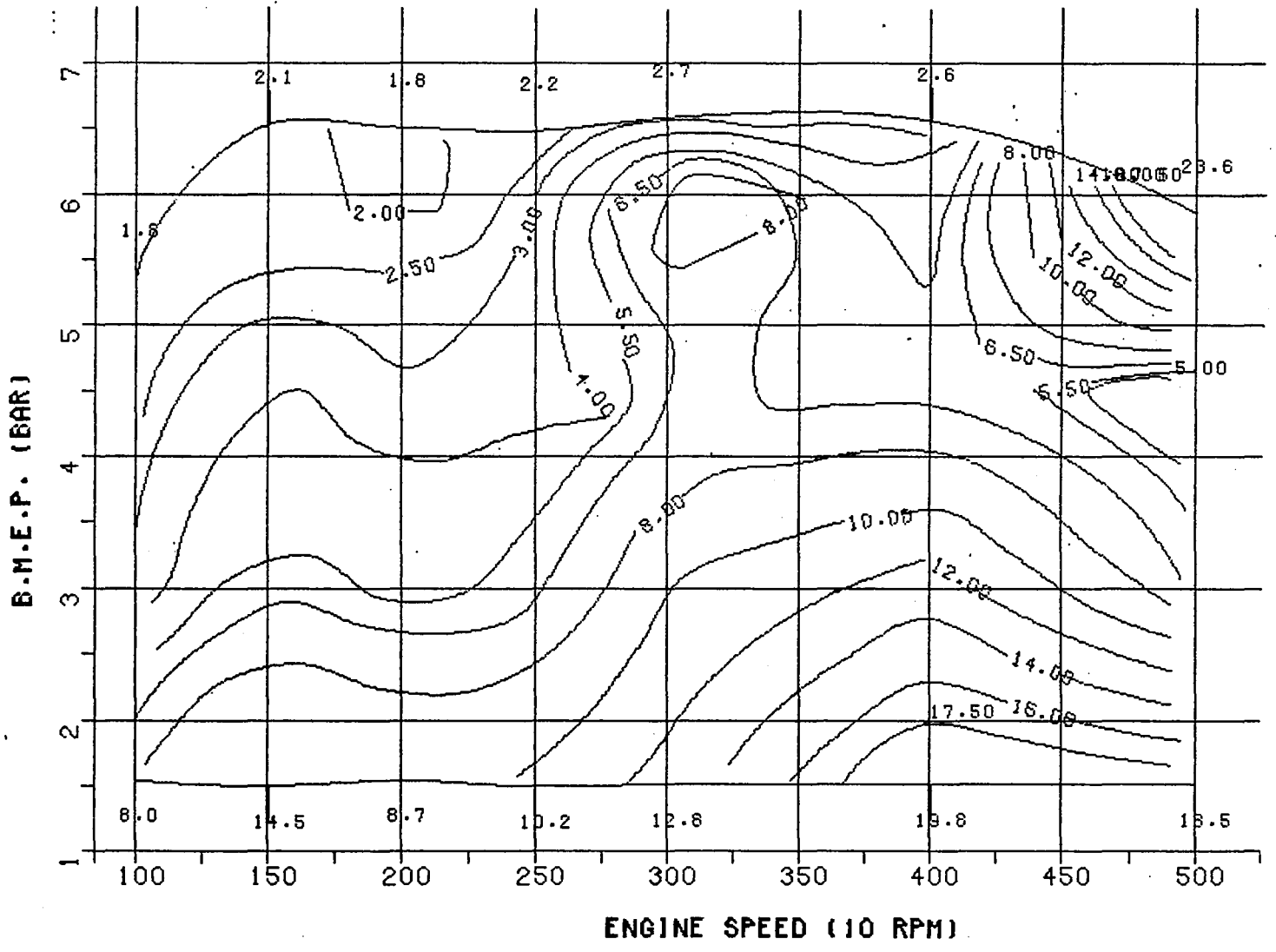

CO EMISSION (G/KWH)
 50 HP N.A. DIESEL ENGINE WITH MODULATED E.G.R.

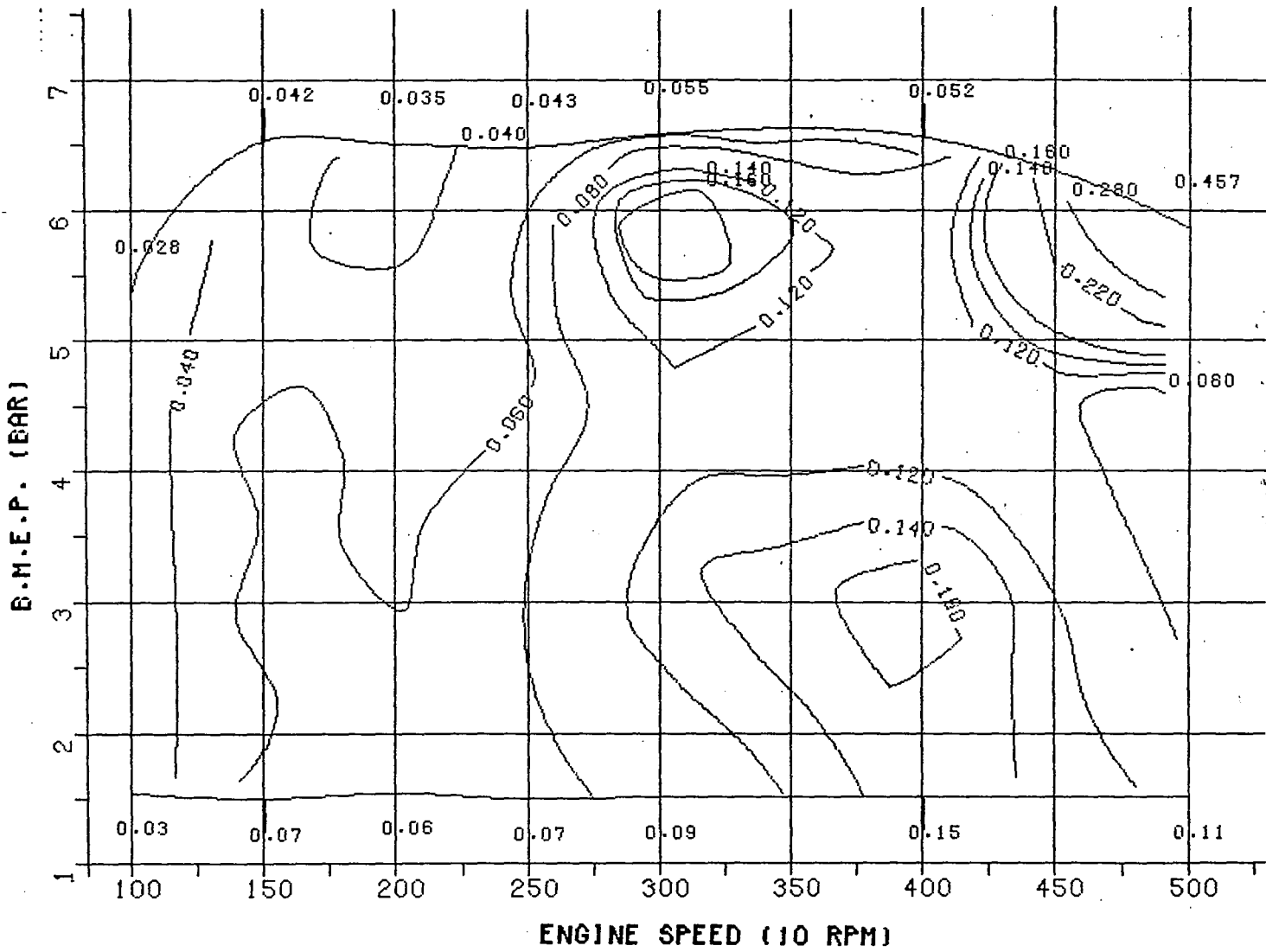

CO CONCENTRATION (%)
 50 HP N.A. DIESEL ENGINE WITH MODULATED E.G.R.

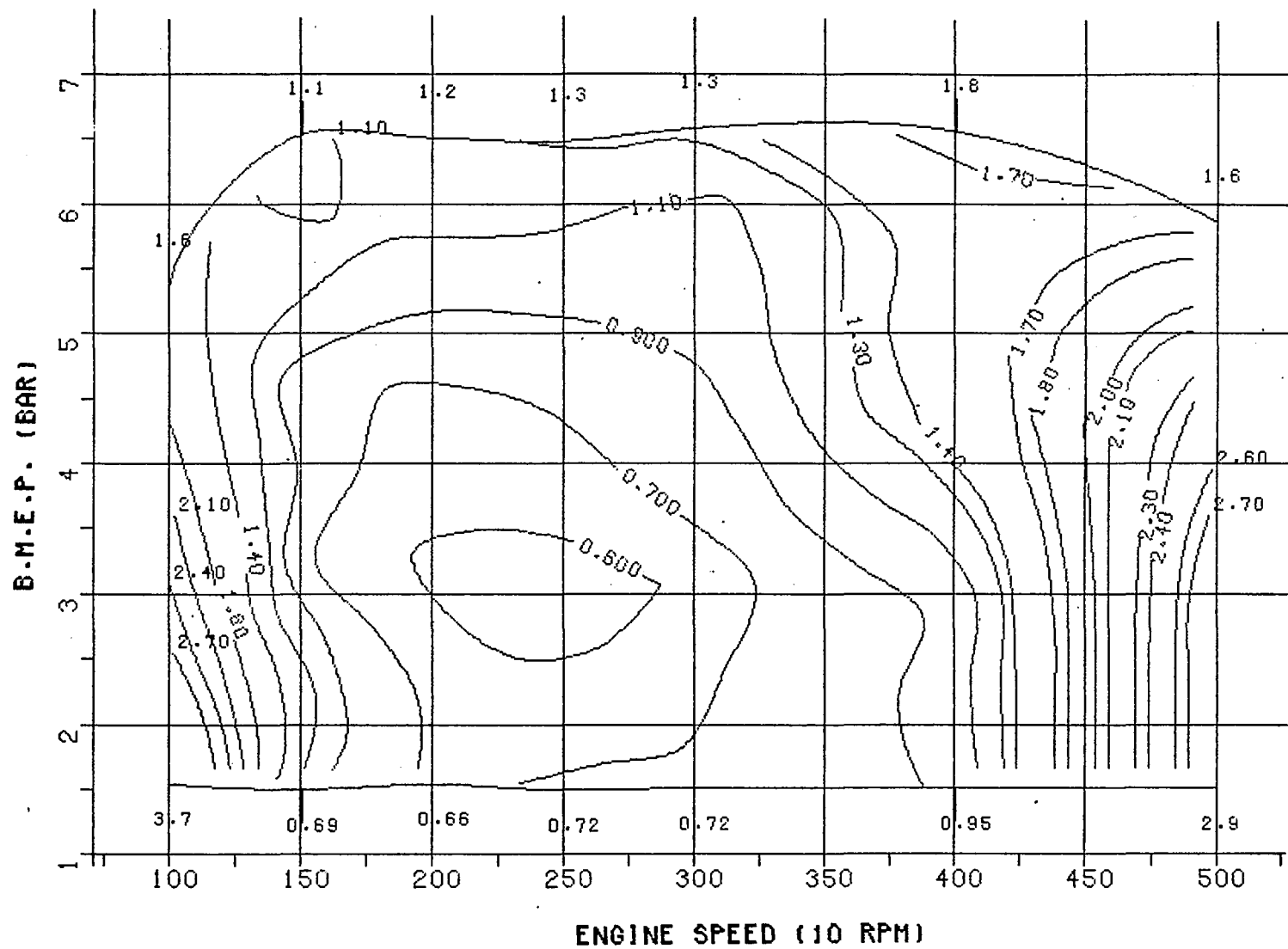

NO EMISSION (G/KWH)
 50 HP N.A. DIESEL ENGINE WITH MODULATED E.G.R.

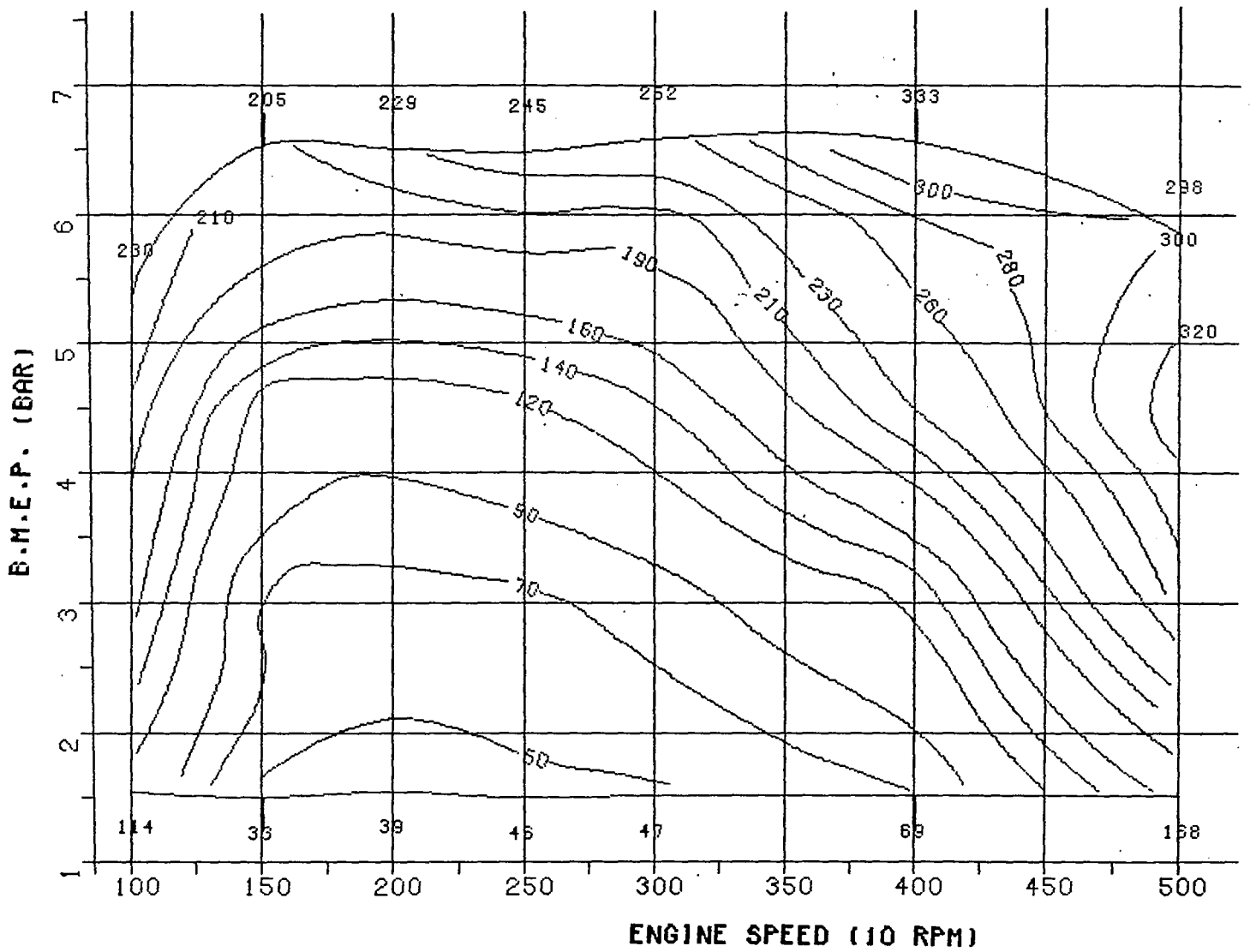

NO CONCENTRATION (PPM)
 50 HP N.A. DIESEL ENGINE WITH MODULATED E.G.R.

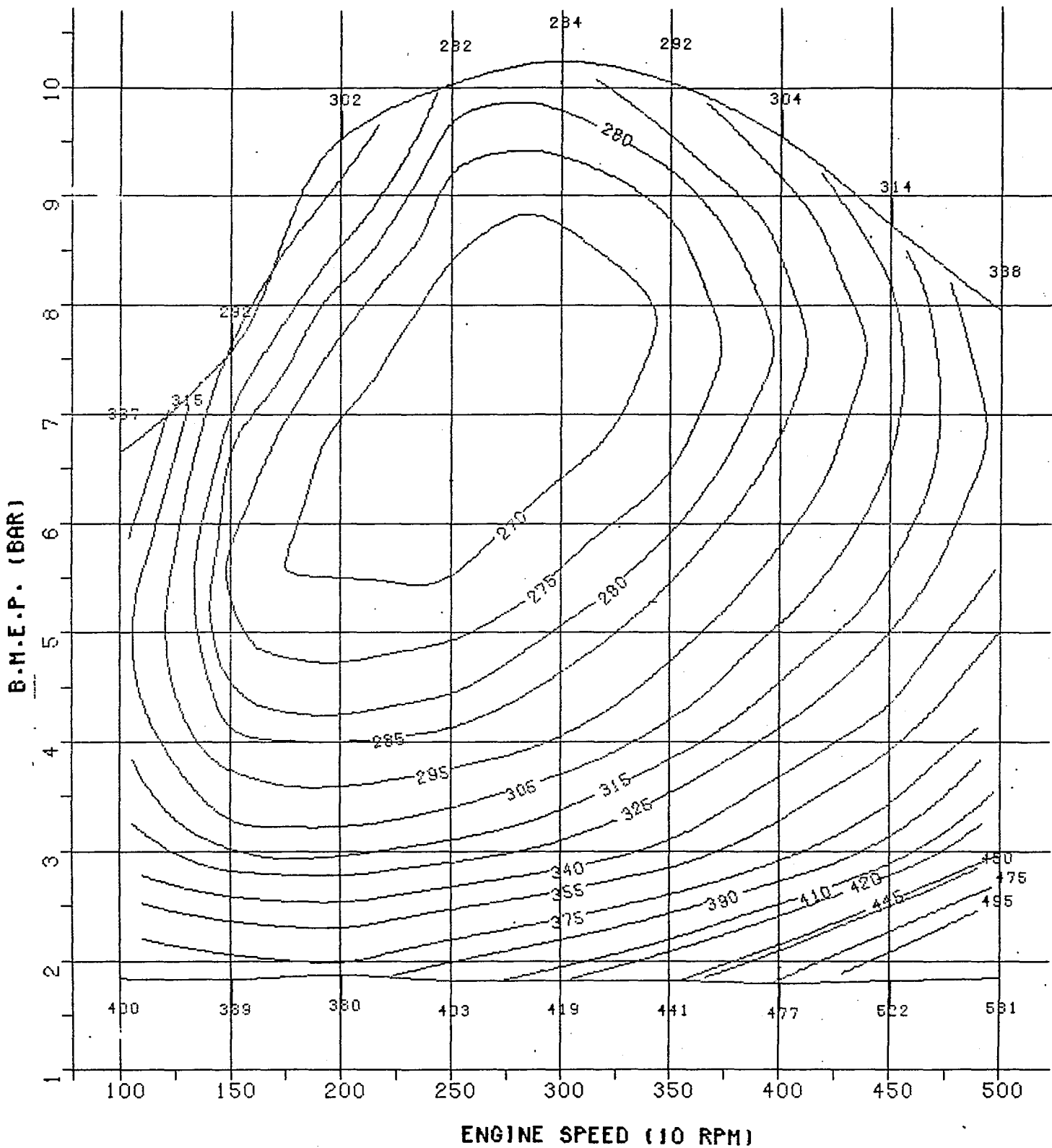

SPECIFIC FUEL CONSUMPTION (G/KWH)
70 HP TURBOCHARGED RESEARCH DIESEL ENGINE

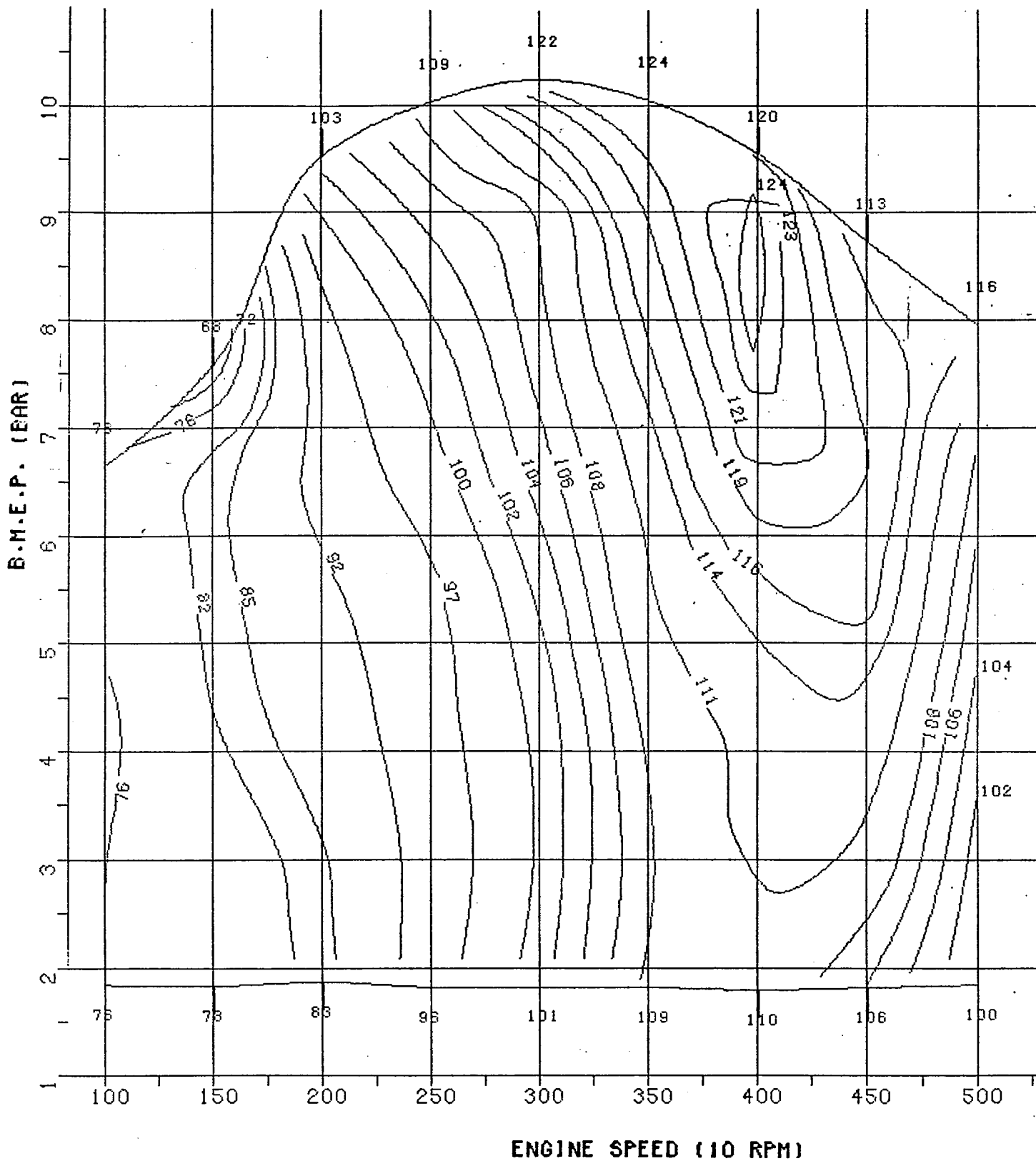

OIL TEMPERATURE (CELSIUS)
 70 HP TURBOCHARGED RESEARCH DIESEL ENGINE

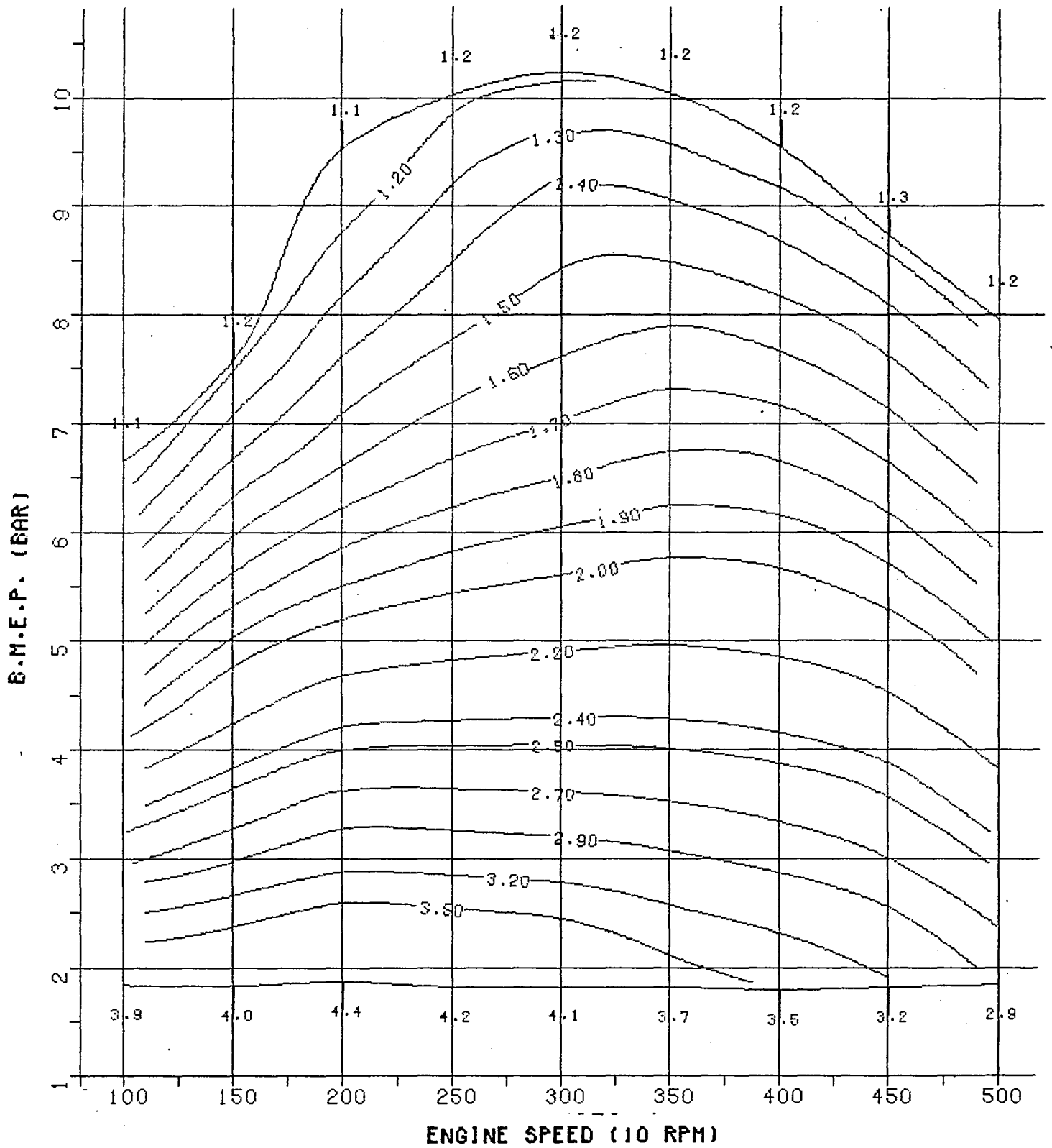

AIR TO FUEL RATIO
70 HP TURBOCHARGED RESEARCH DIESEL ENGINE

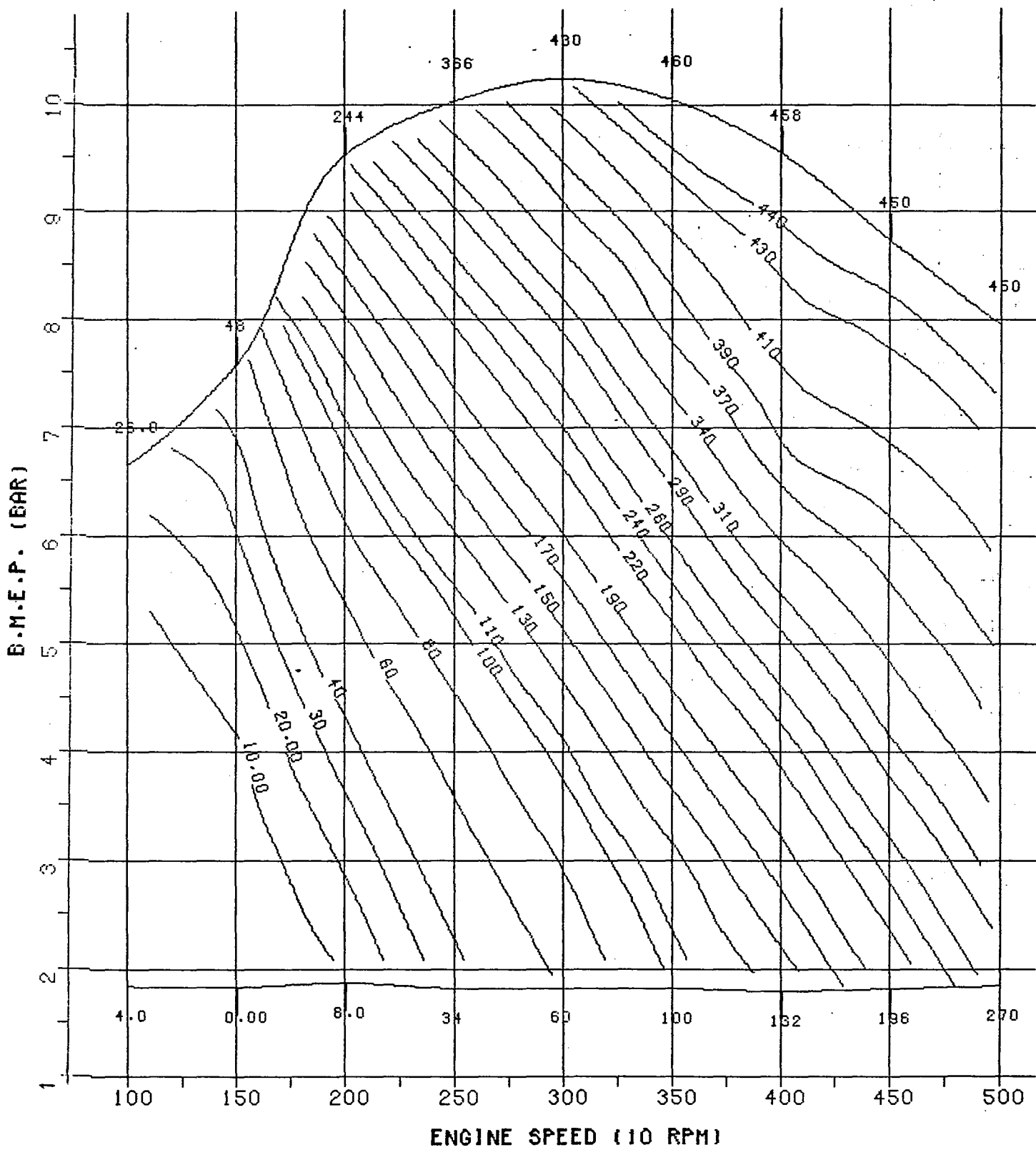

TURBOCHARGE PRESSURE (TORR)
 70 HP TURBOCHARGED RESEARCH DIESEL ENGINE

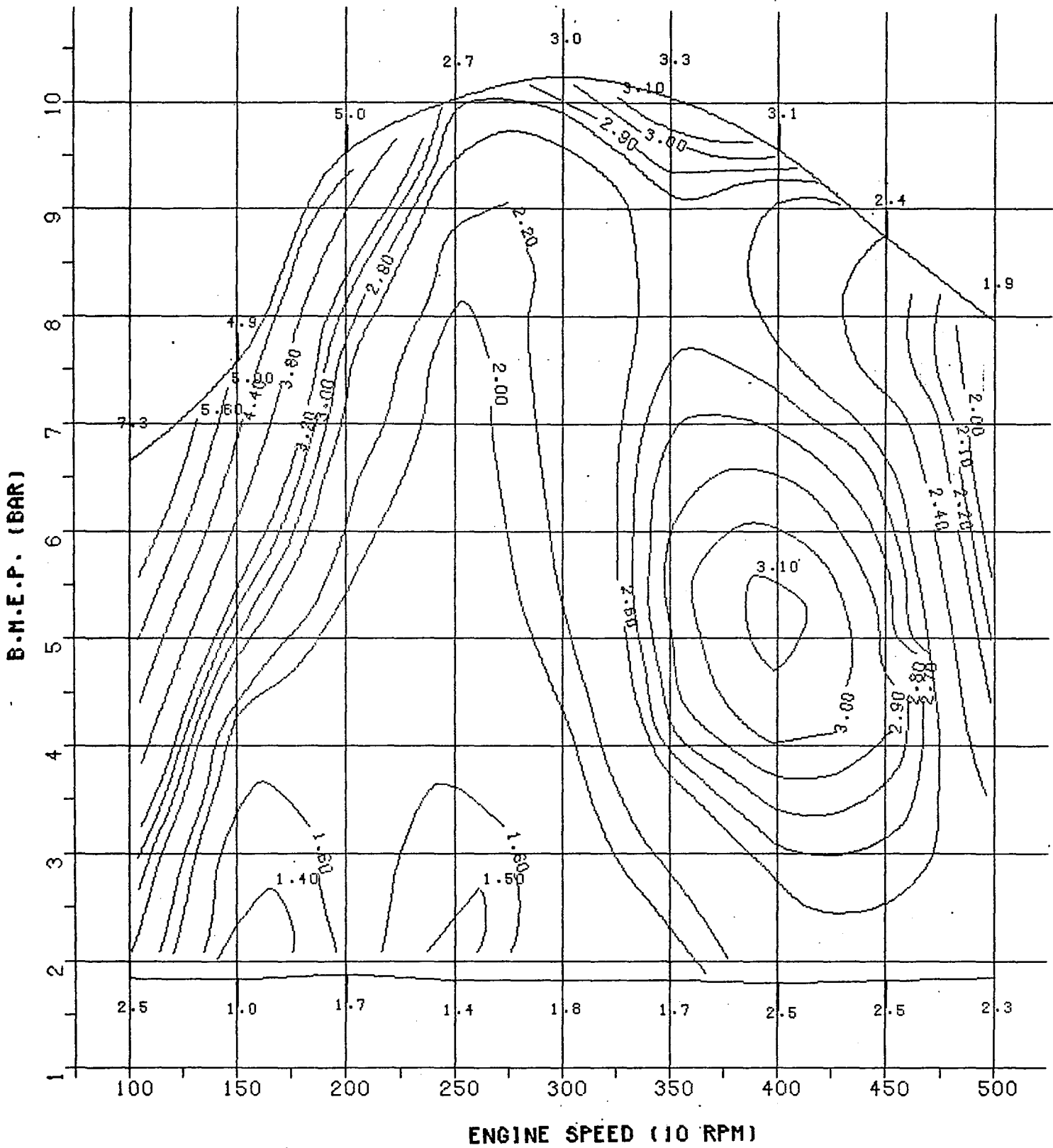

SMOKE (BOSCH NUMBER)
70 HP TURBOCHARGED RESEARCH DIESEL ENGINE

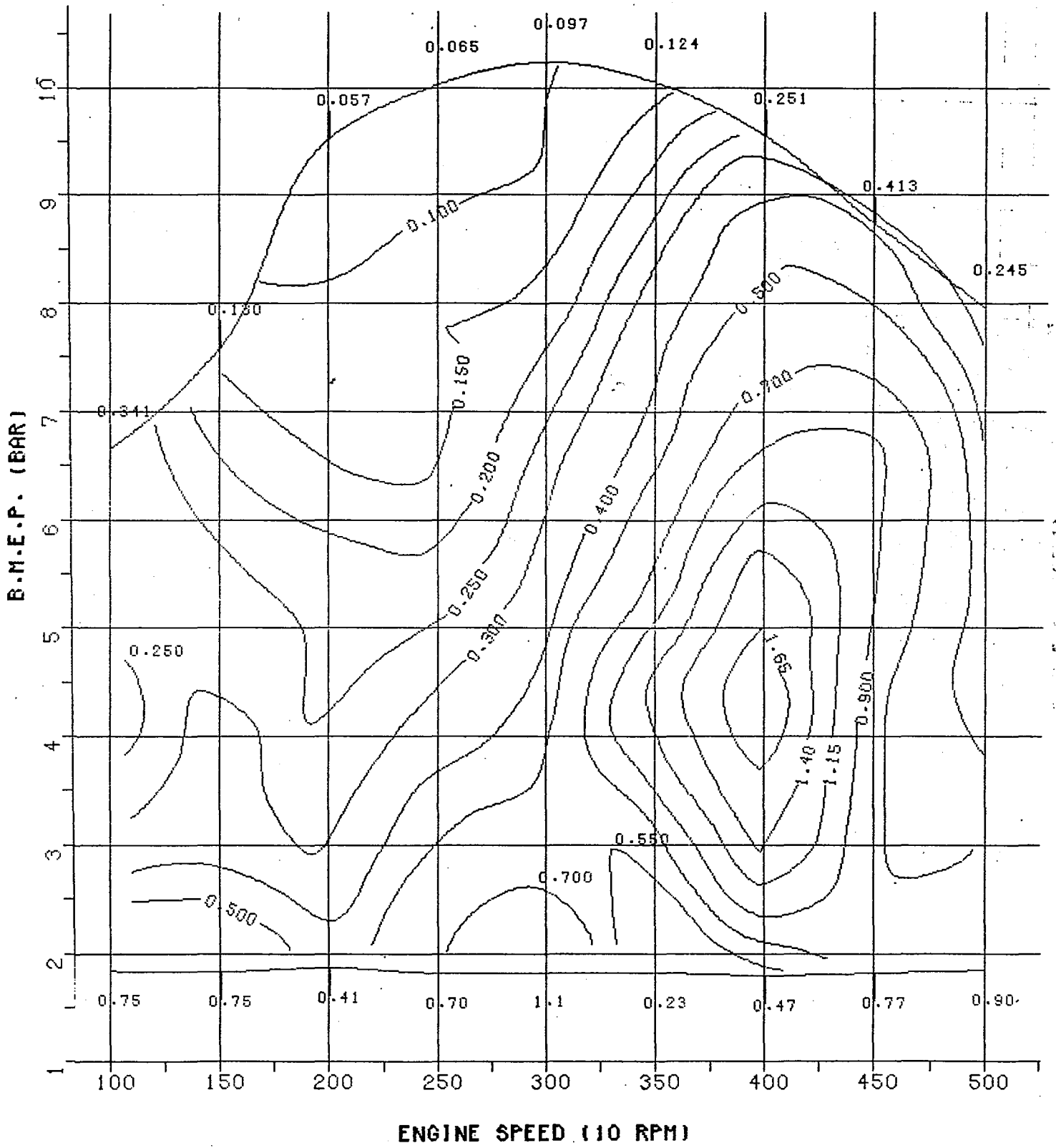

HC EMISSION (G/KWH)
 70 HP TURBOCHARGED RESEARCH DIESEL ENGINE

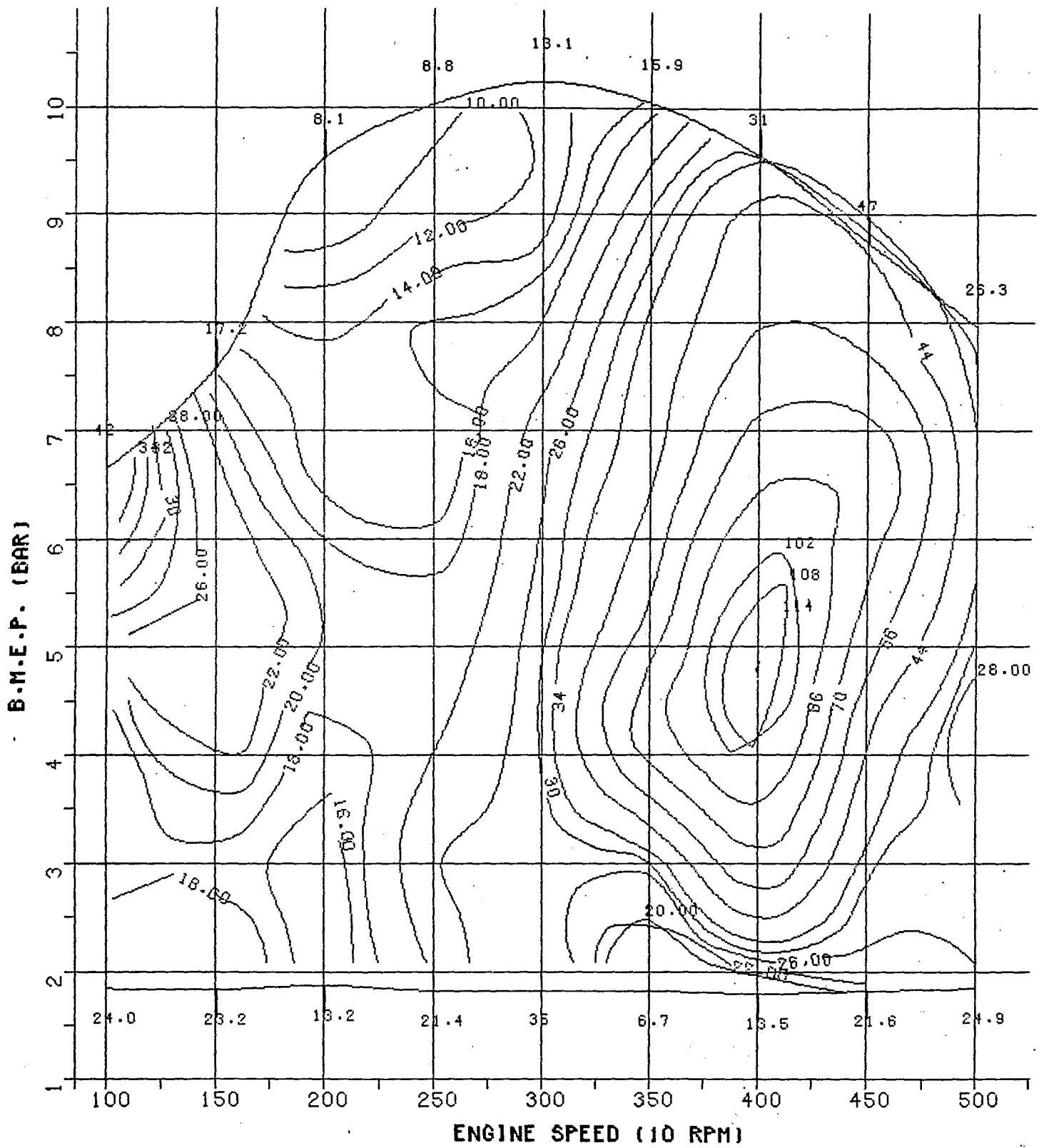

HC CONCENTRATION (PPM)
 70 HP TURBOCHARGED RESEARCH DIESEL ENGINE

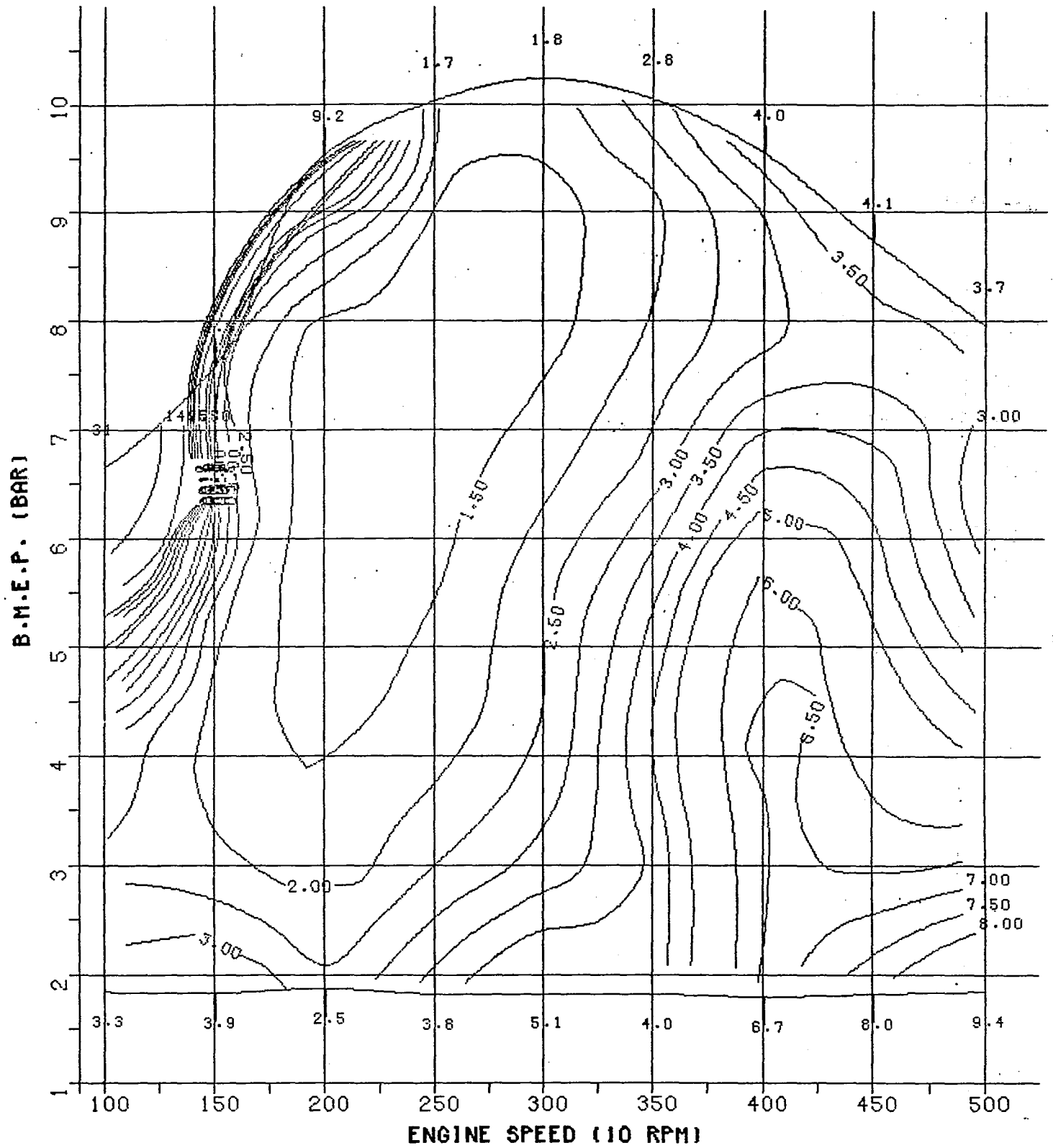

CO EMISSION (G/KWH)
70 HP TURBOCHARGED RESEARCH DIESEL ENGINE

B.M.E.P. (BAR)

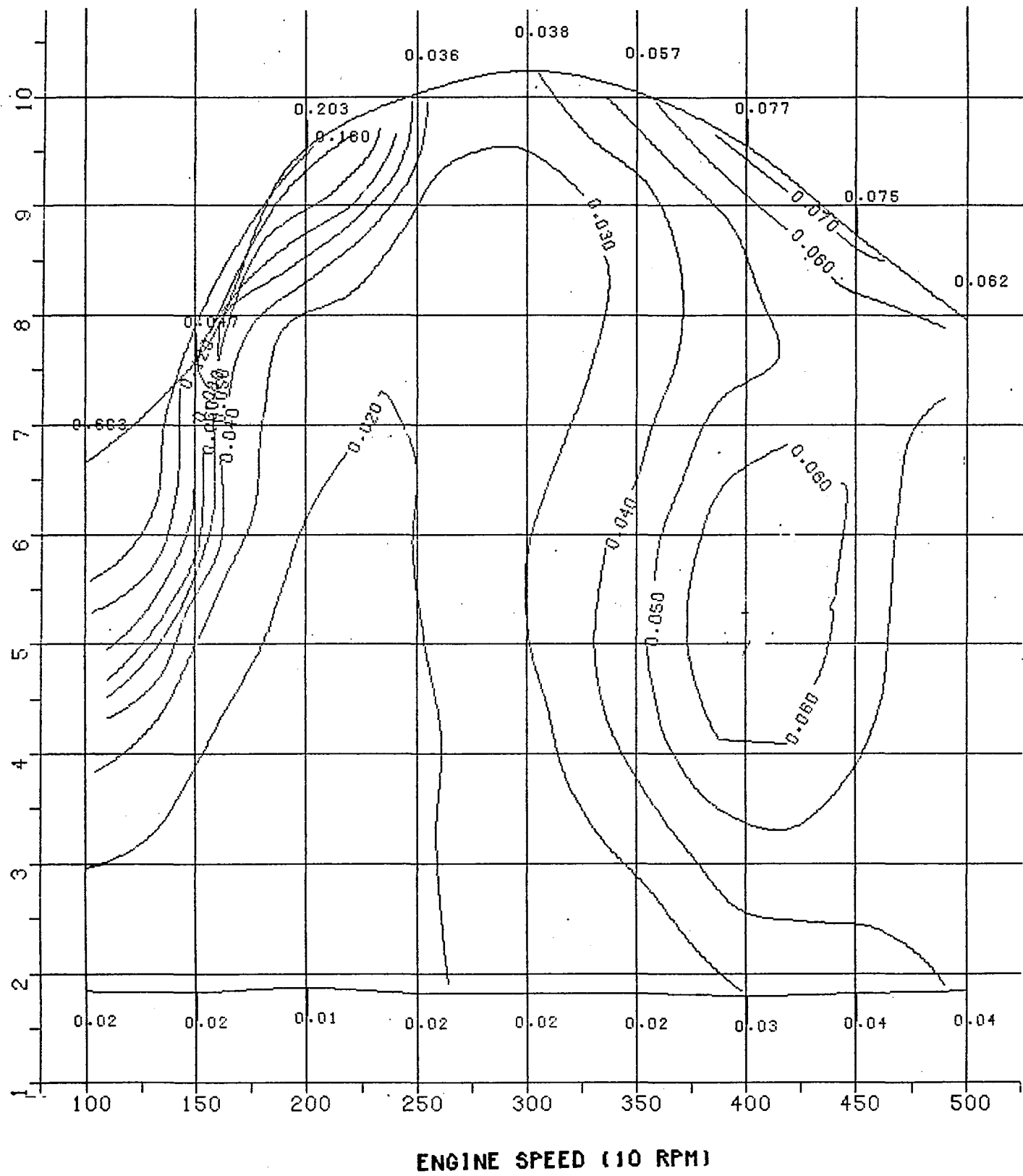

CO CONCENTRATION (%)
70 HP TURBOCHARGED RESEARCH DIESEL ENGINE

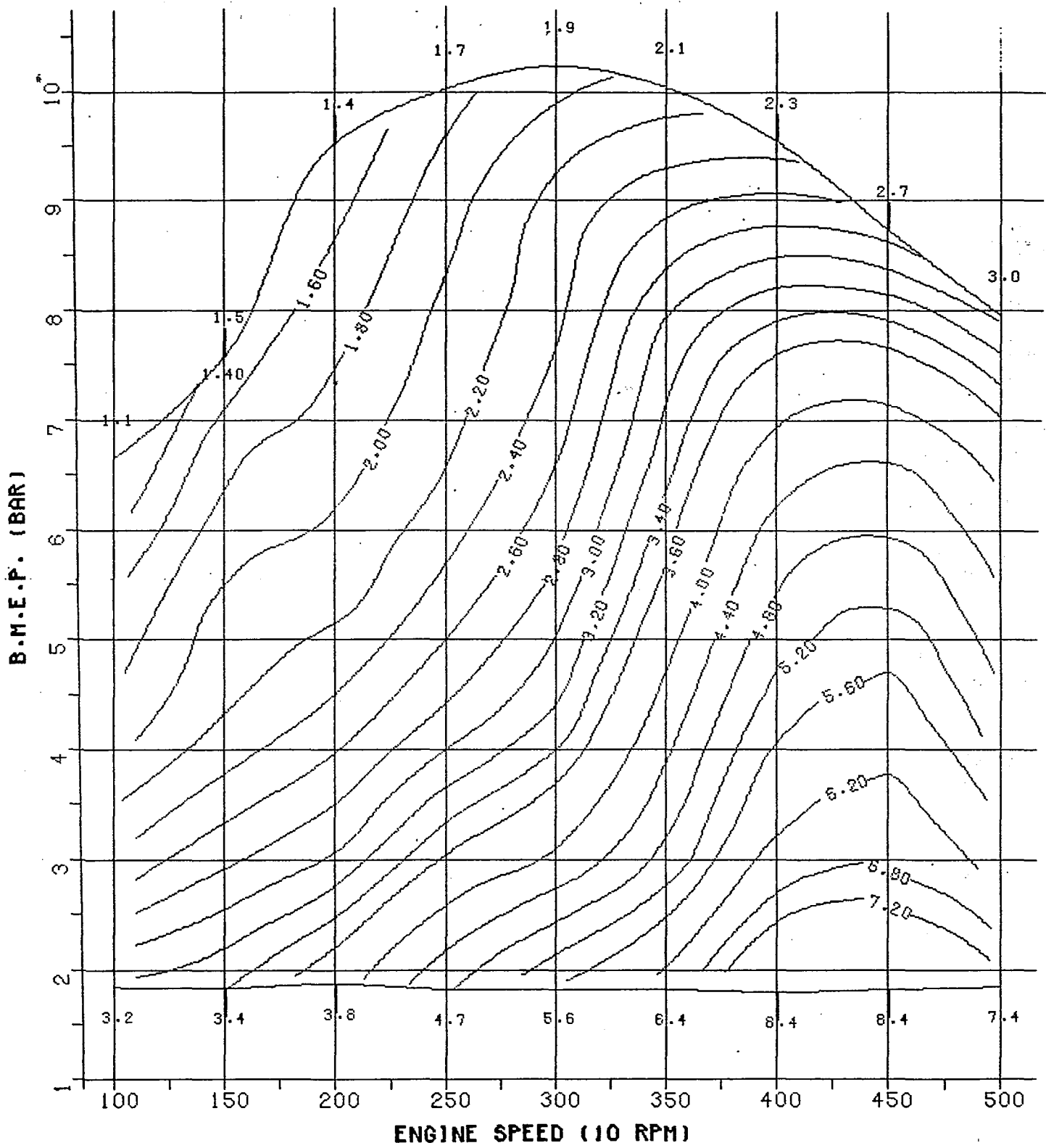

NO EMISSION (G/KWH)
 70 HP TURBOCHARGED RESEARCH DIESEL ENGINE

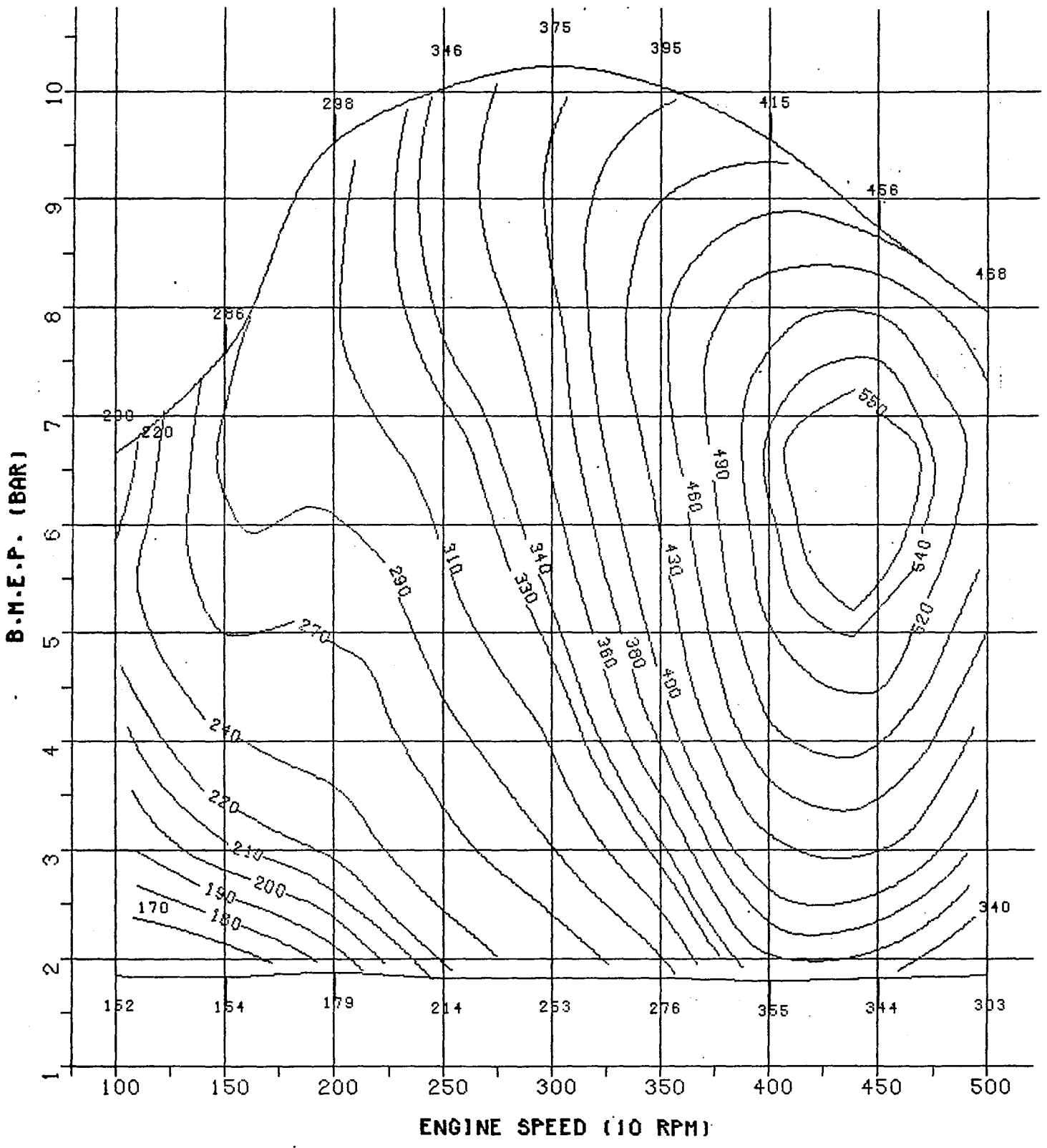

NO CONCENTRATION (PPM)
70 HP TURBOCHARGED RESEARCH DIESEL ENGINE

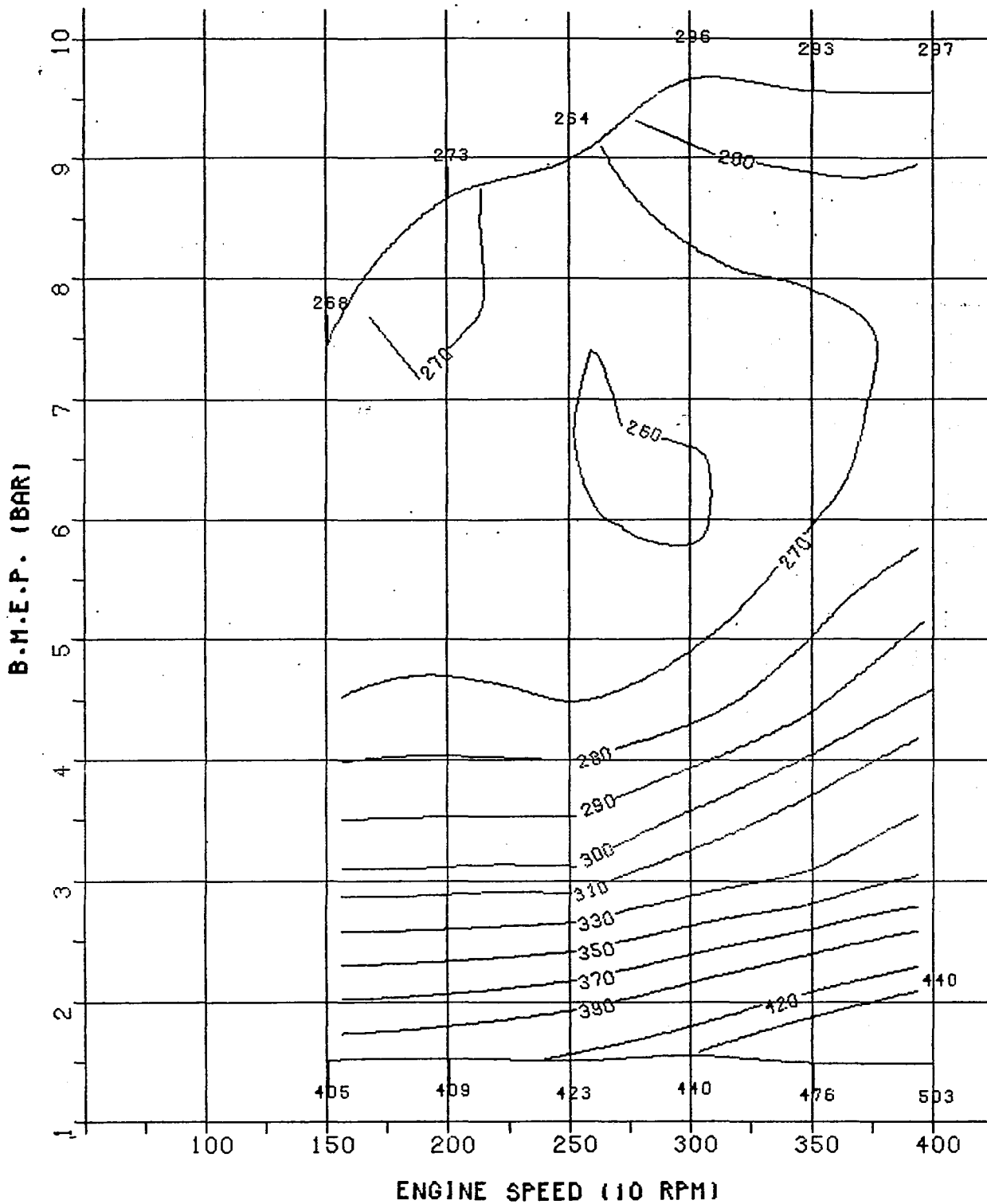

SPECIFIC FUEL CONSUMPTION (G/KWH)
 70 HP TC DIESEL ENGINE WITH MODULATED E.G.R.

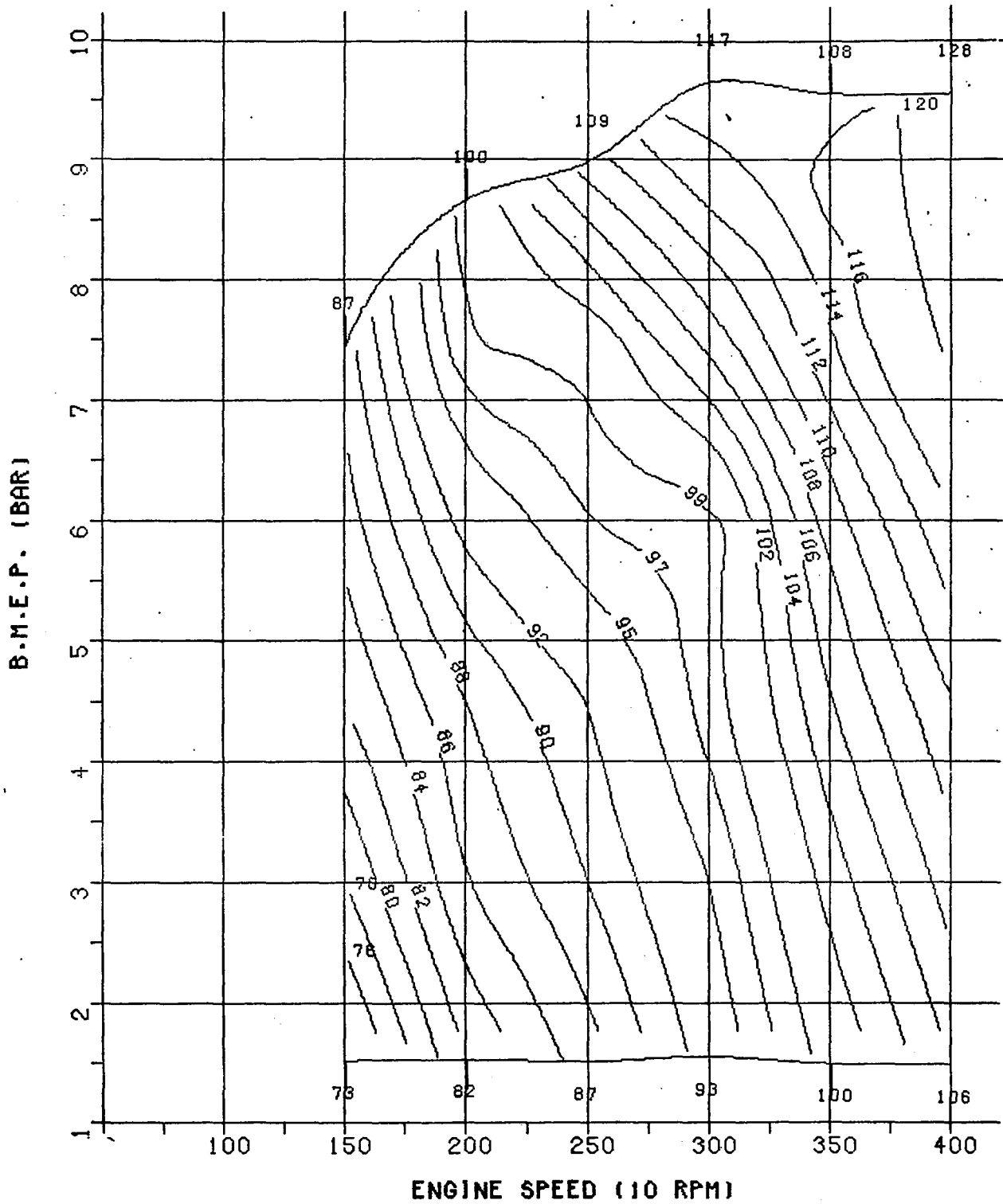

OIL TEMPERATURE (CELSIUS)
 70 HP TC DIESEL ENGINE WITH MODULATED E.G.R.

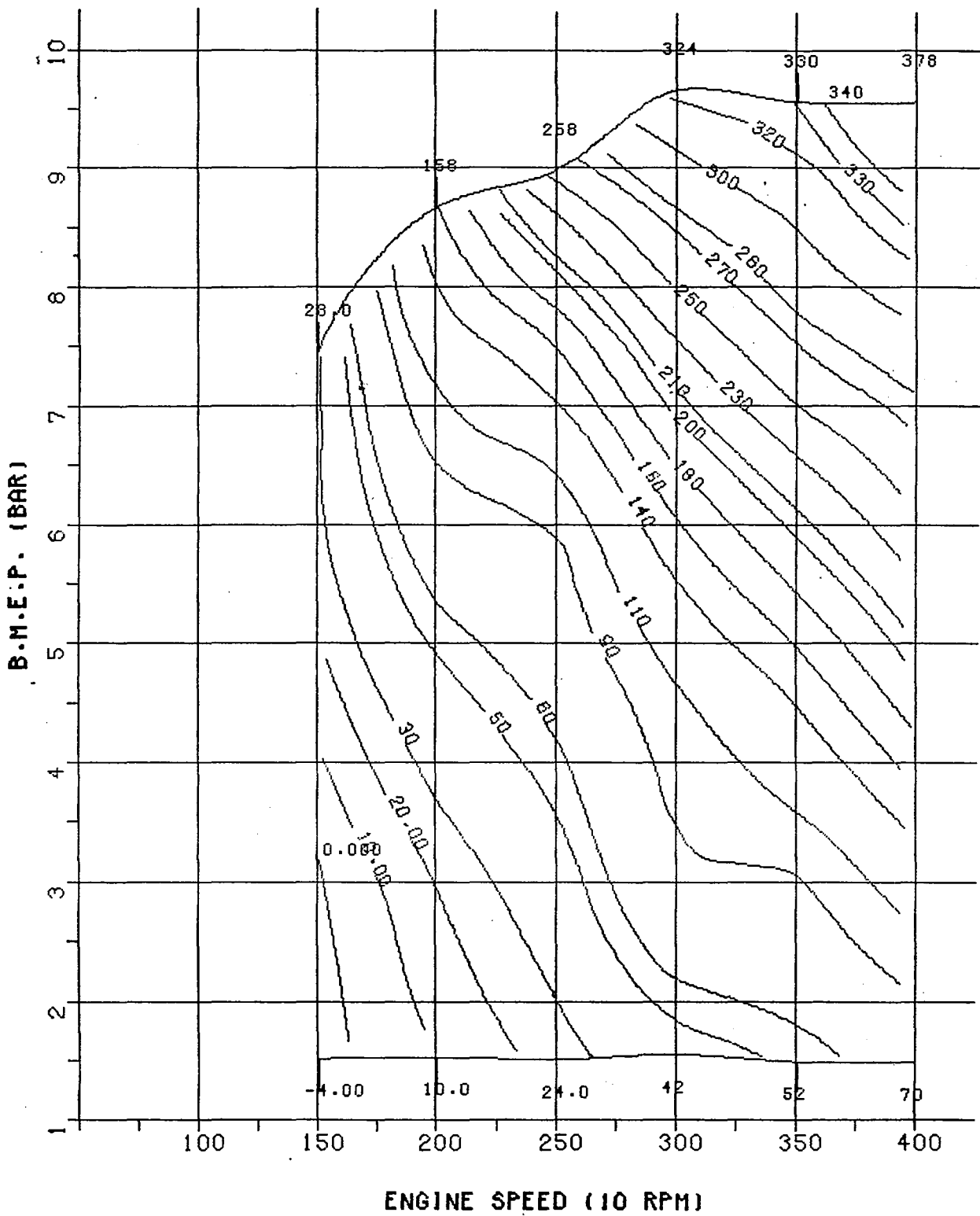

TURBOCHARGE PRESSURE (TORR)
 70 HP TC DIESEL ENGINE WITH MODULATED E.G.R.

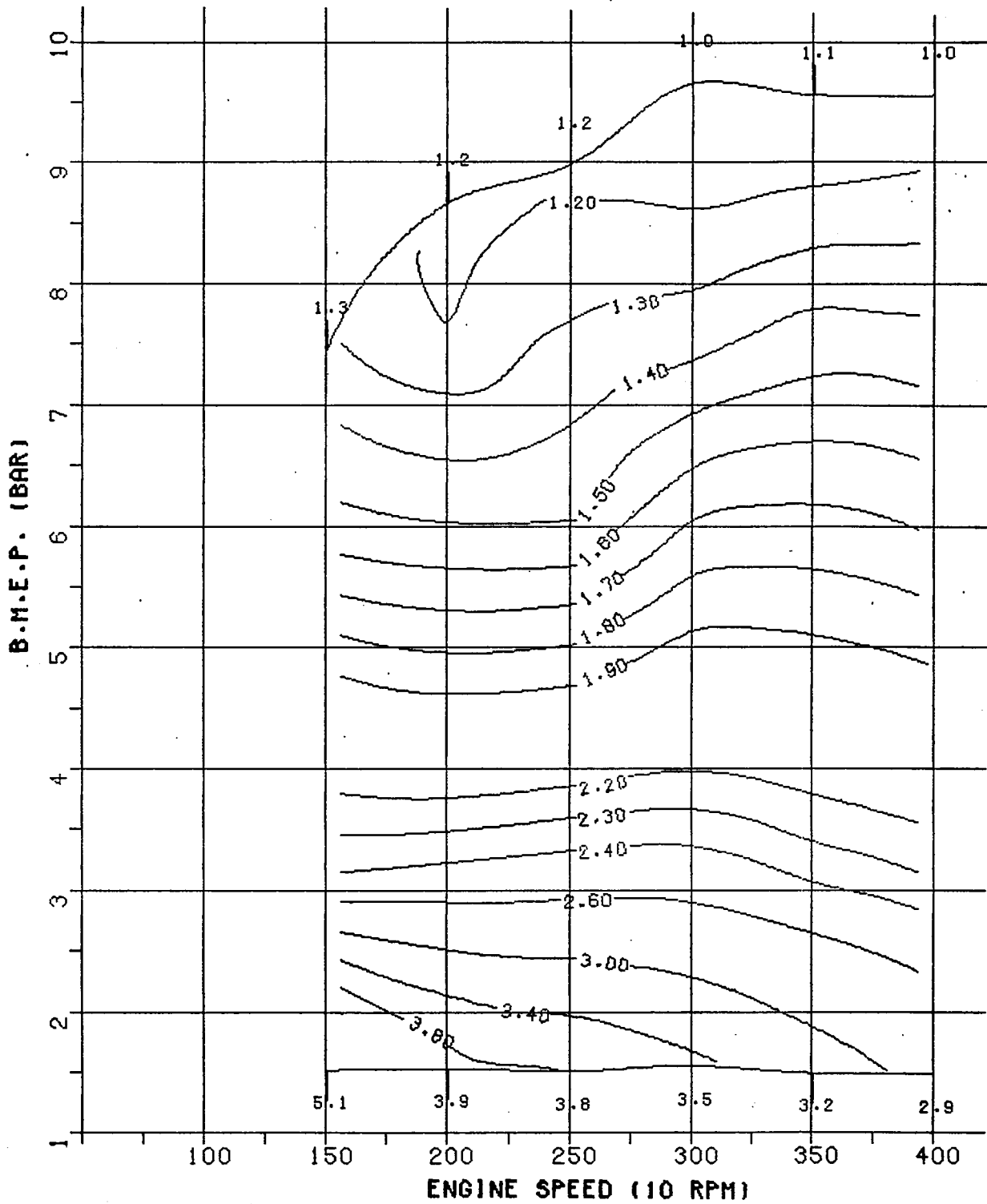

AIR TO FUEL RATIO
70 HP TC DIESEL ENGINE WITH MODULATED E.G.R.

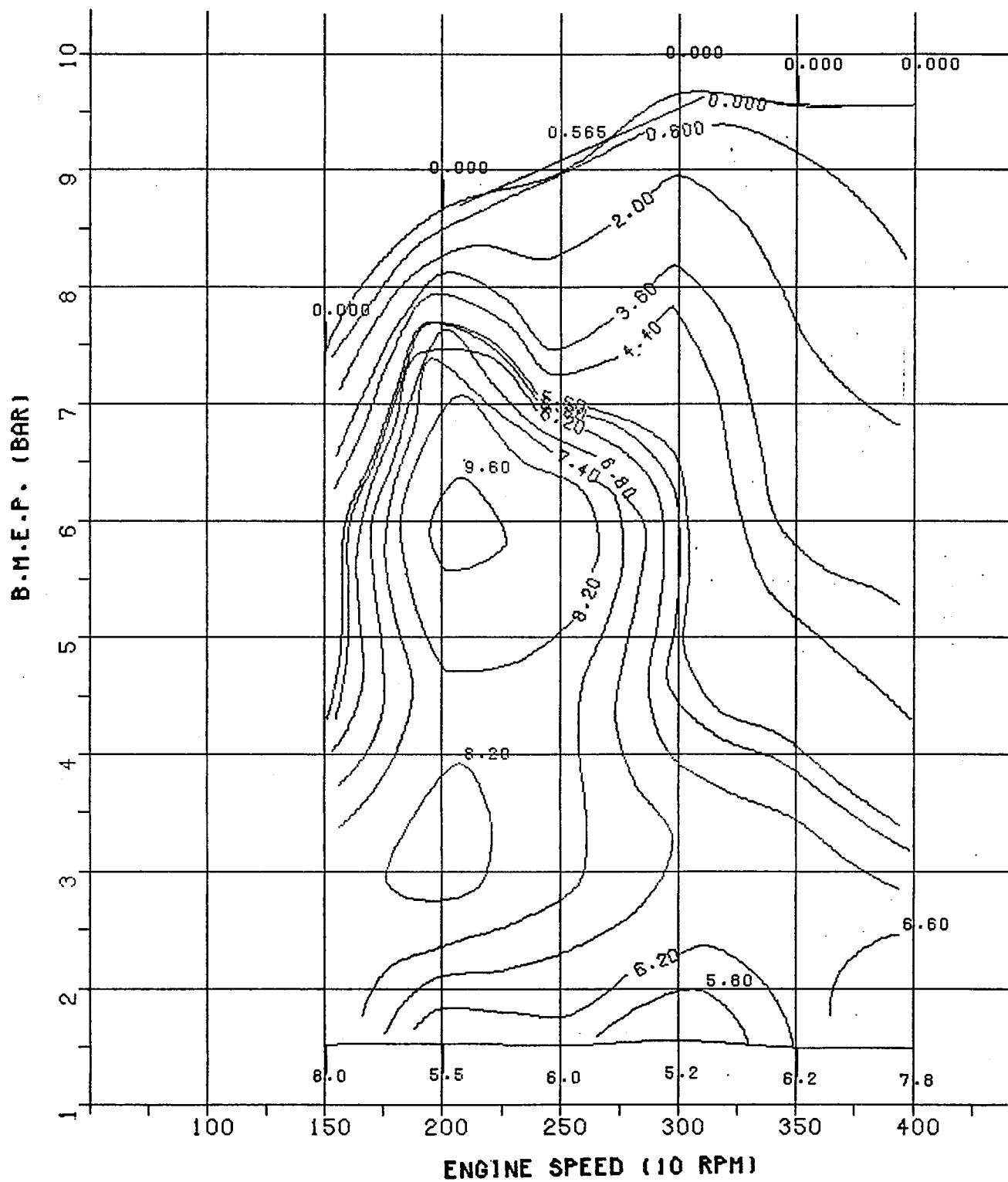

EFFECTIVE E.G.R. (%)
 70 HP TC DIESEL ENGINE WITH MODULATED E.G.R.

B.M.E.P. (BAR)

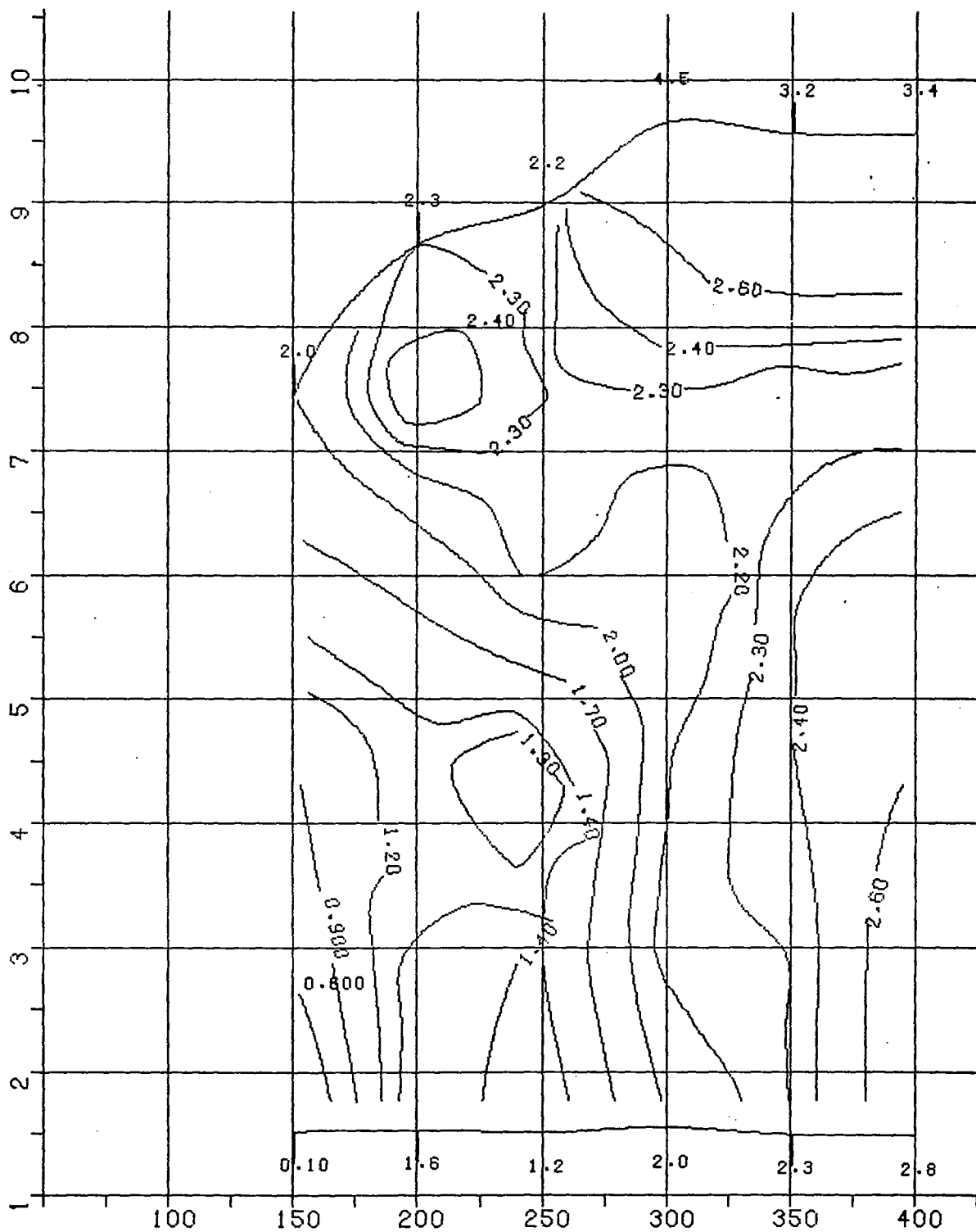

ENGINE SPEED (10 RPM)

SMOKE (BOSCH NUMBER)

70 HP TC DIESEL ENGINE WITH MODULATED E.G.R.

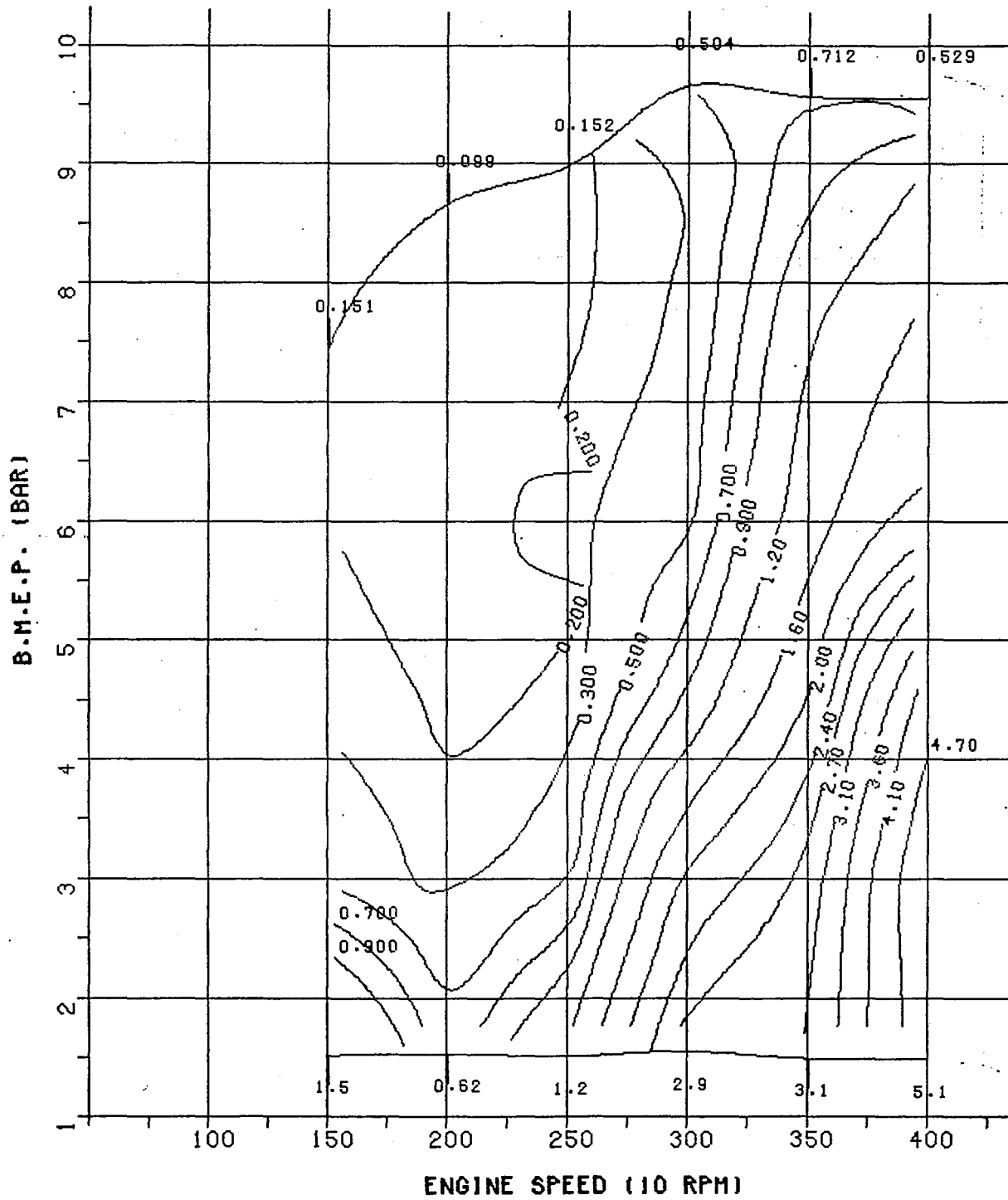

HC EMISSION (G/KWH)
 70 HP TC DIESEL ENGINE WITH MODULATED E.G.R.

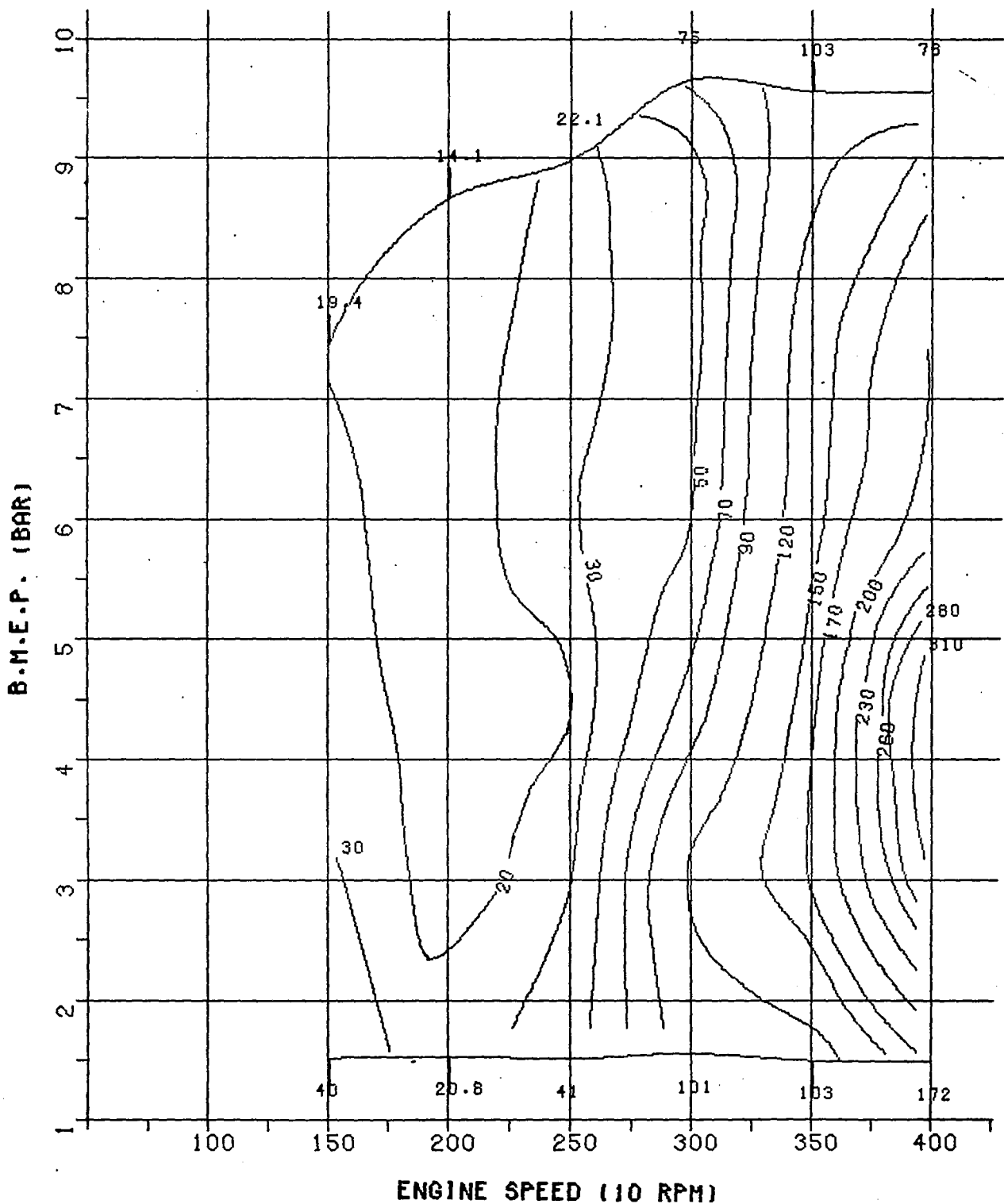

HC CONCENTRATION (PPM)
 70 HP TC DIESEL ENGINE WITH MODULATED E.G.R.

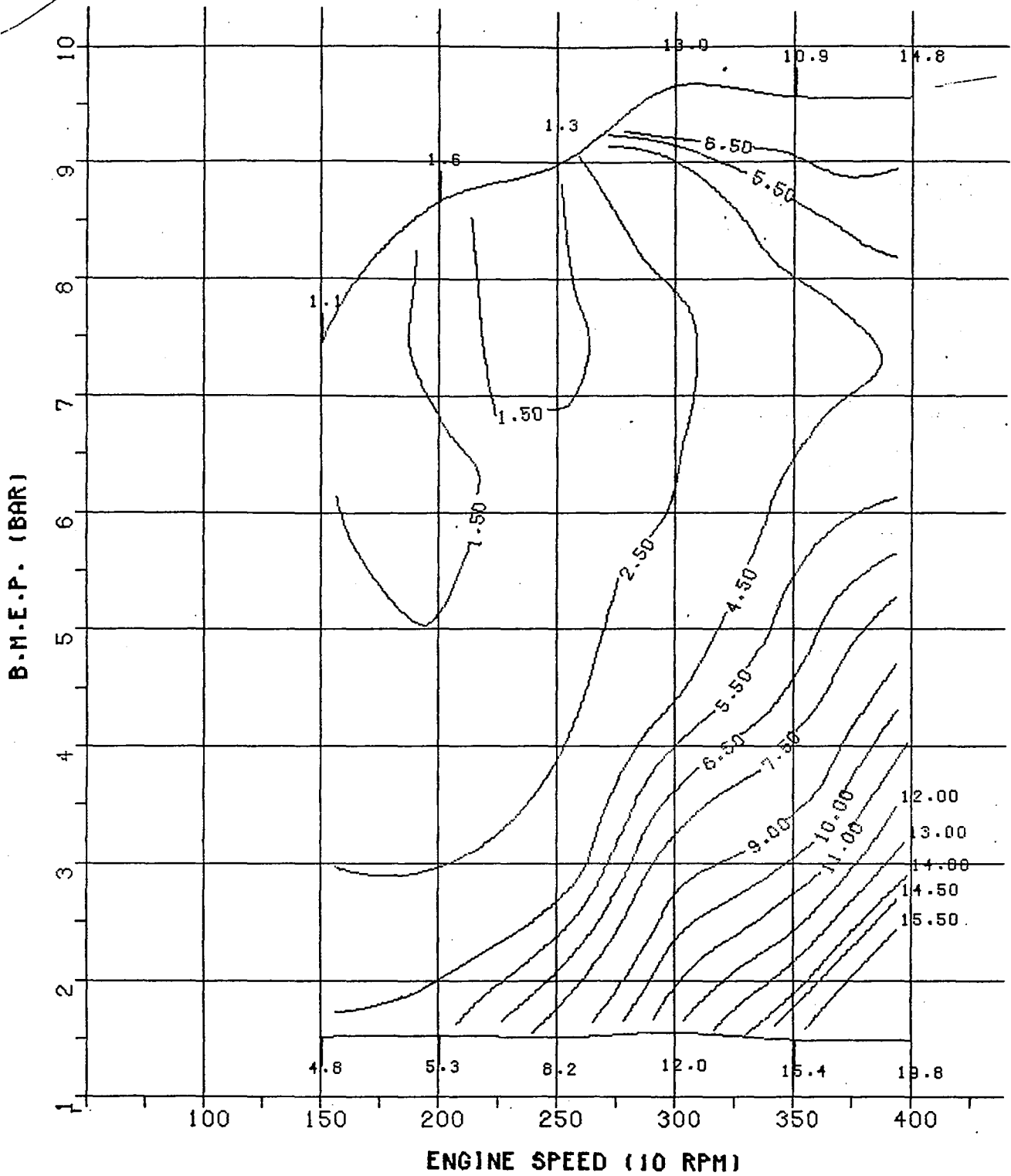

CO EMISSION (G/KWH)
 70 HP TC DIESEL ENGINE WITH MODULATED E.G.R.

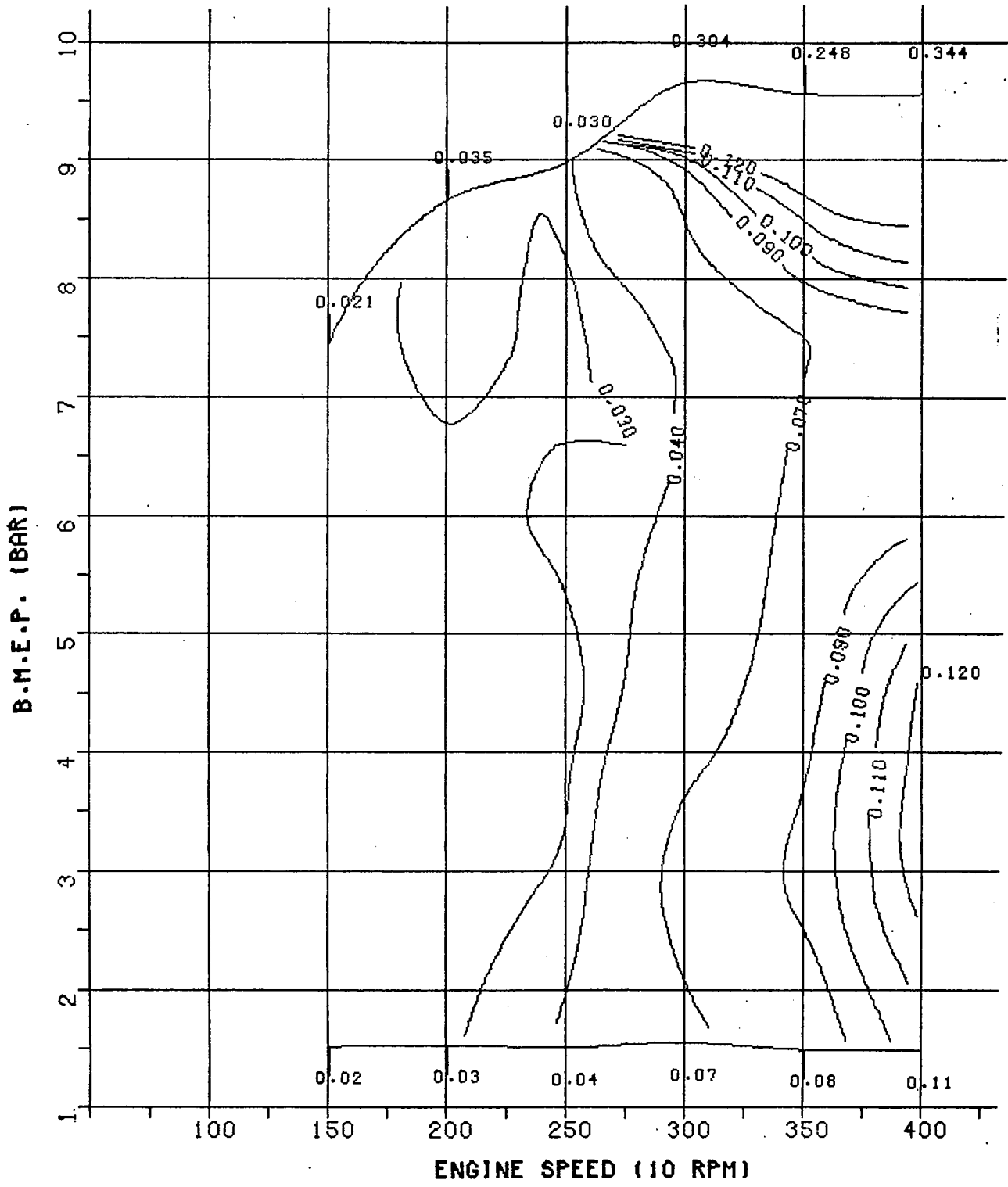

CO CONCENTRATION (%)
 70 HP TC DIESEL ENGINE WITH MODULATED E.G.R.

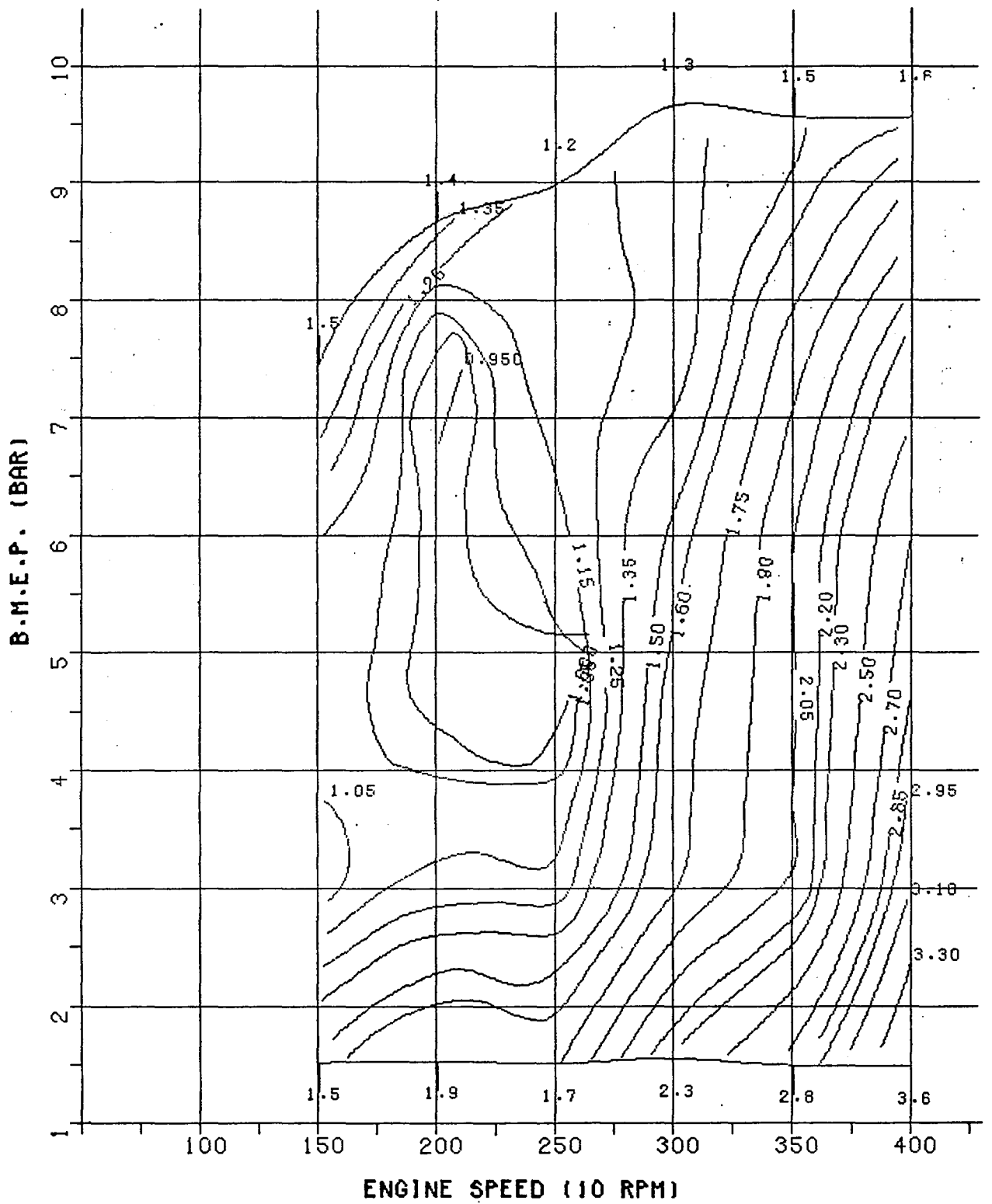

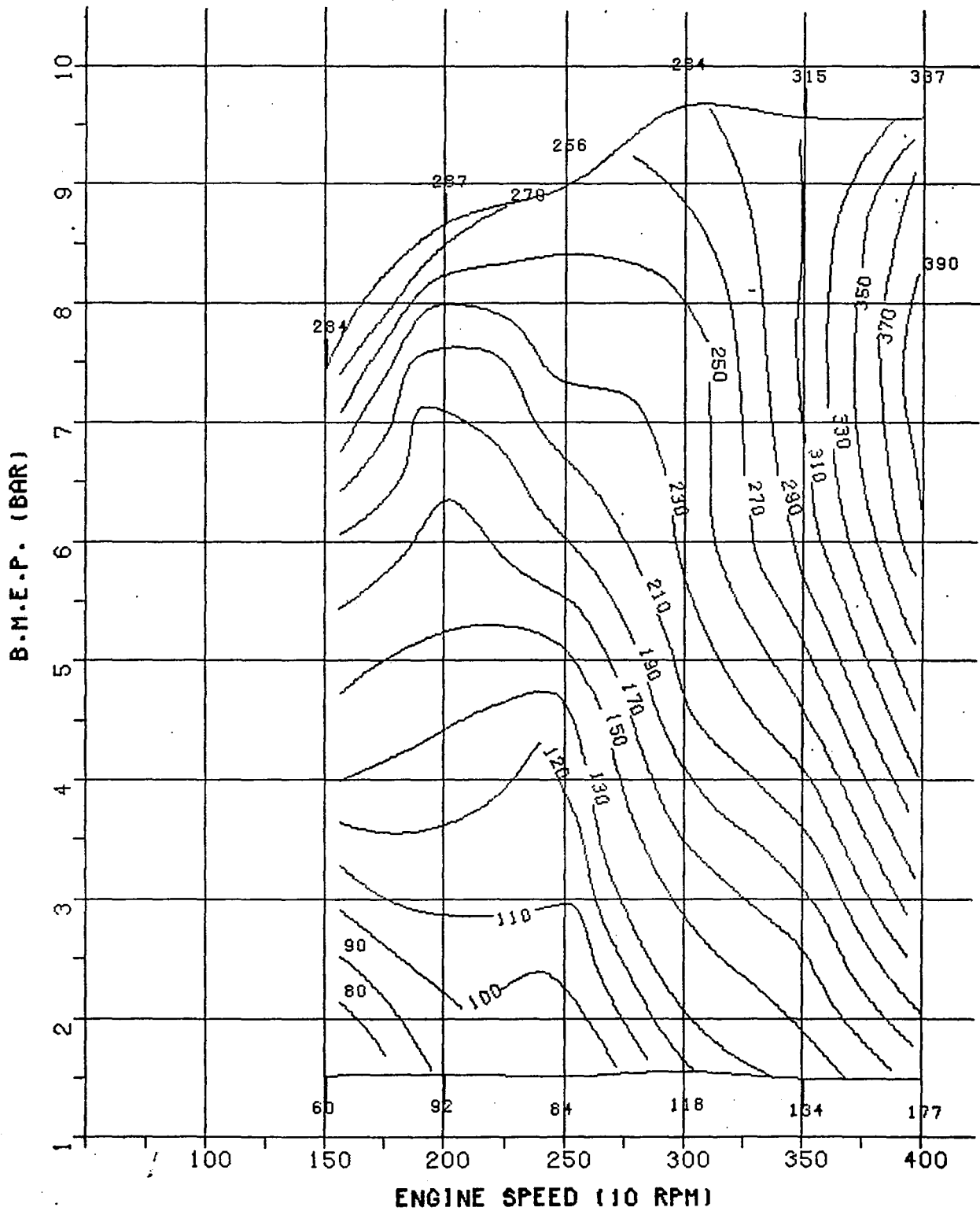

NO CONCENTRATION (PPM)
70 HP TC DIESEL ENGINE WITH MODULATED E.G.R.

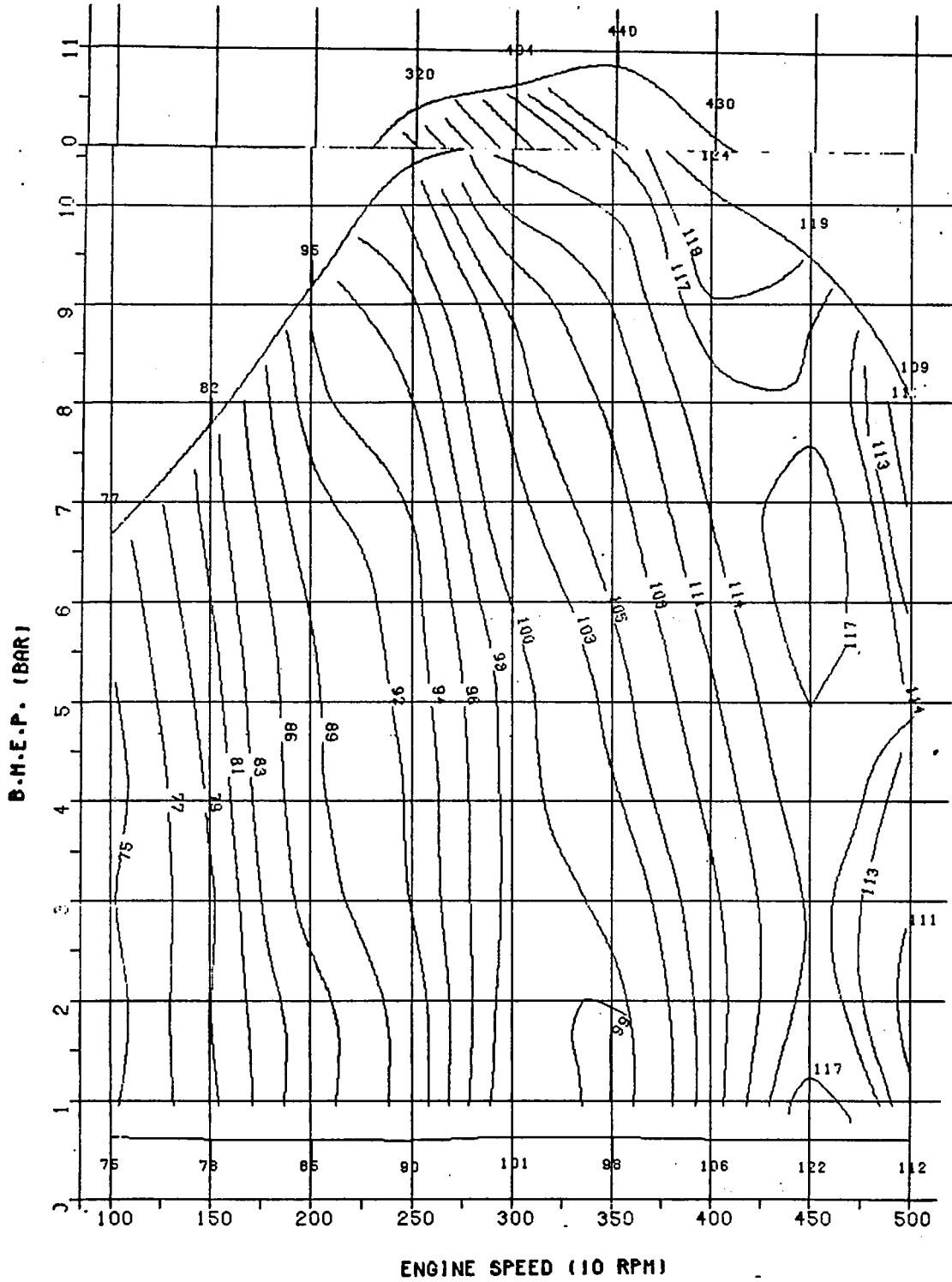

OIL TEMPERATURE (CELSIUS)
70 HP TC DIESEL WITH WATER INJECTION

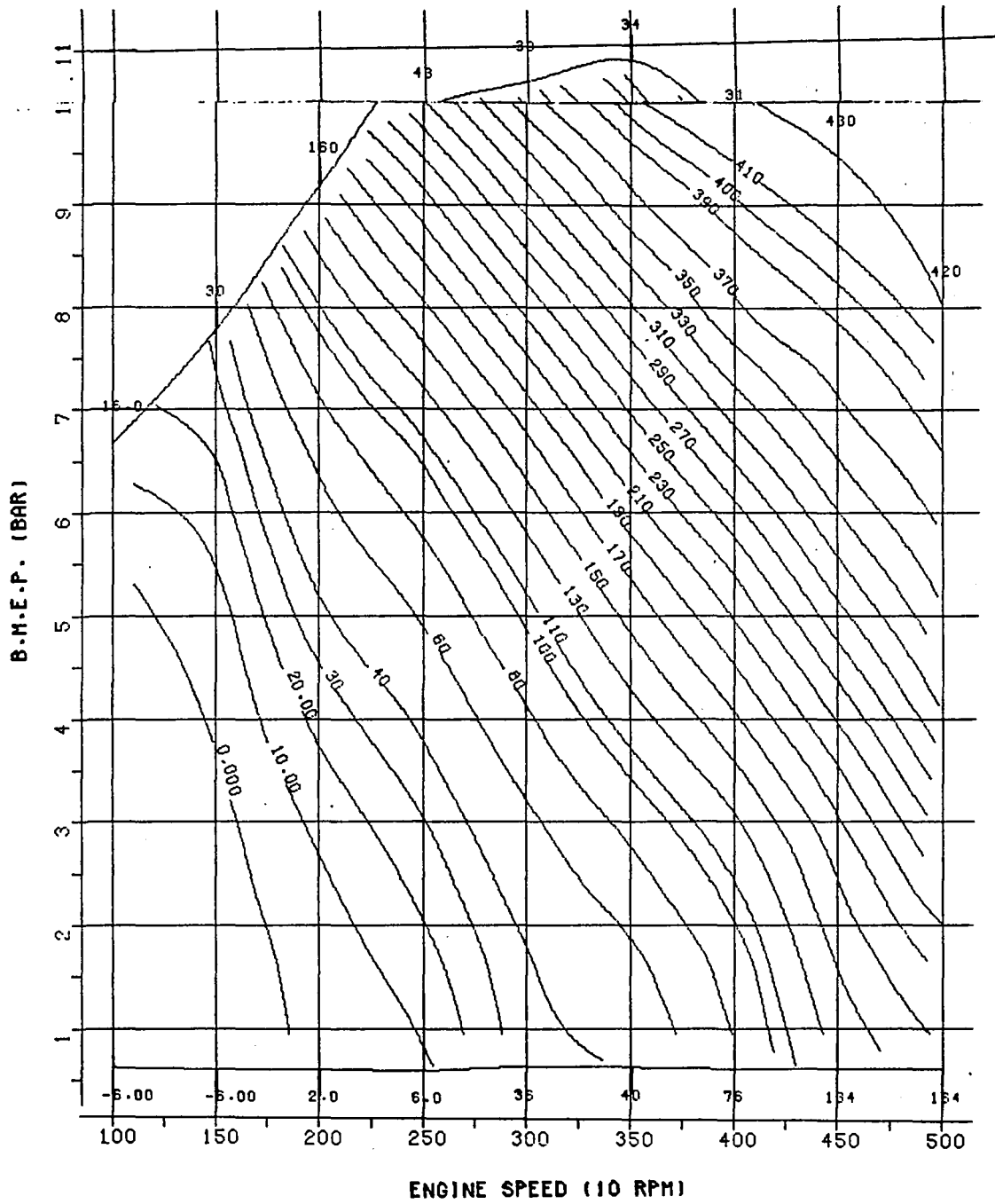

TURBOCHARGE PRESSURE (TORR)
70 HP TC DIESEL WITH WATER INJECTION

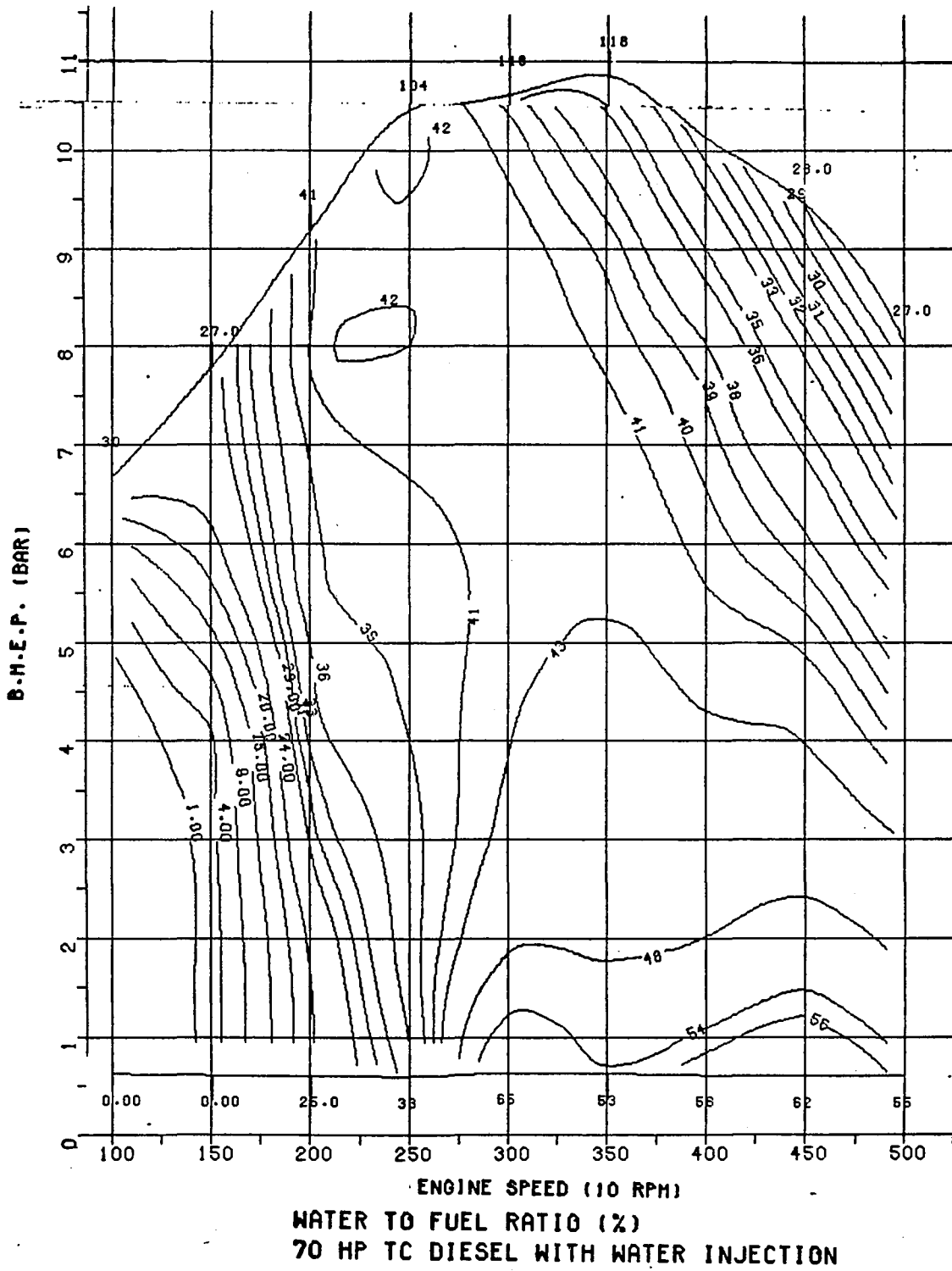

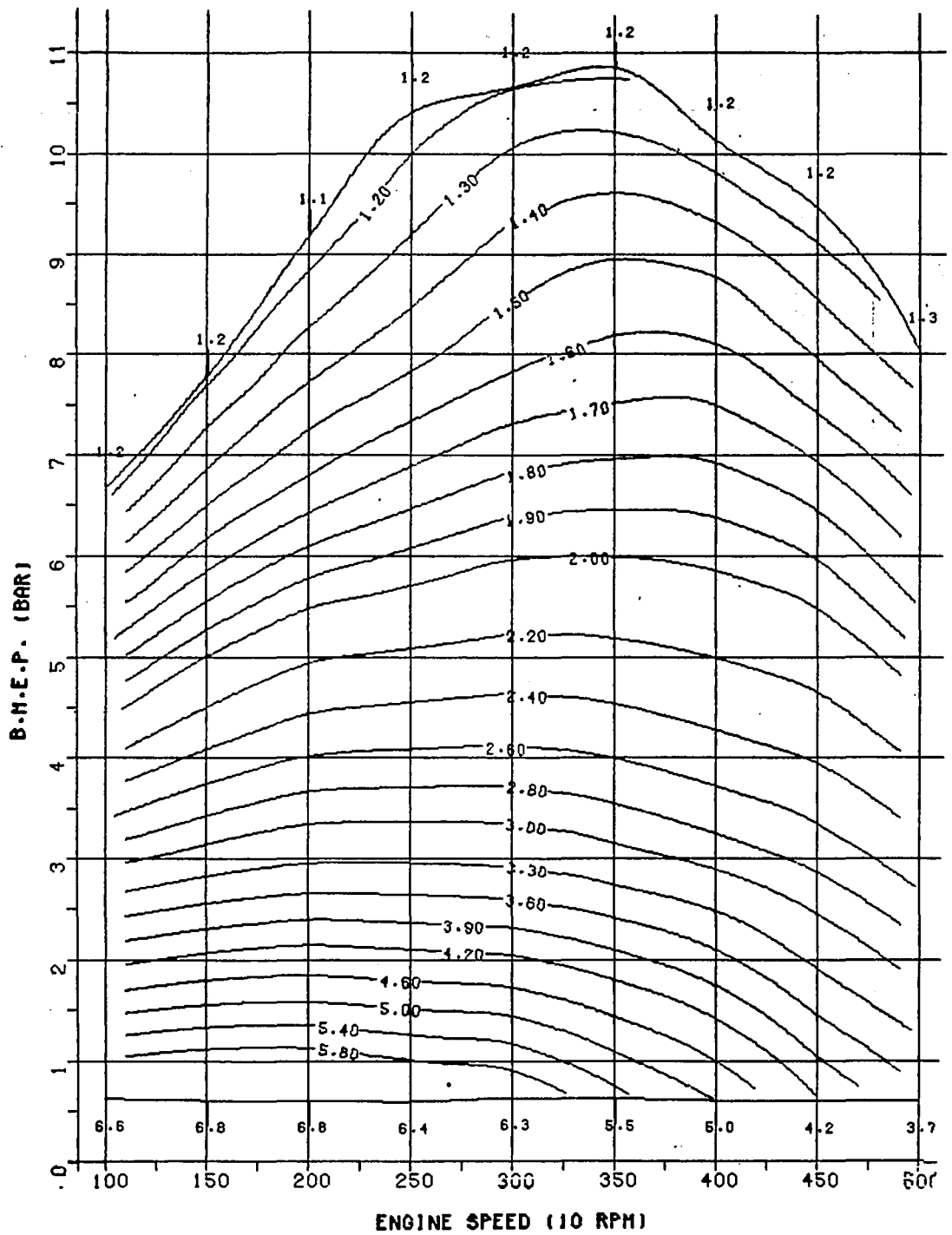

AIR TO FUEL RATIO
70 HP TC DIESEL WITH WATER INJECTION

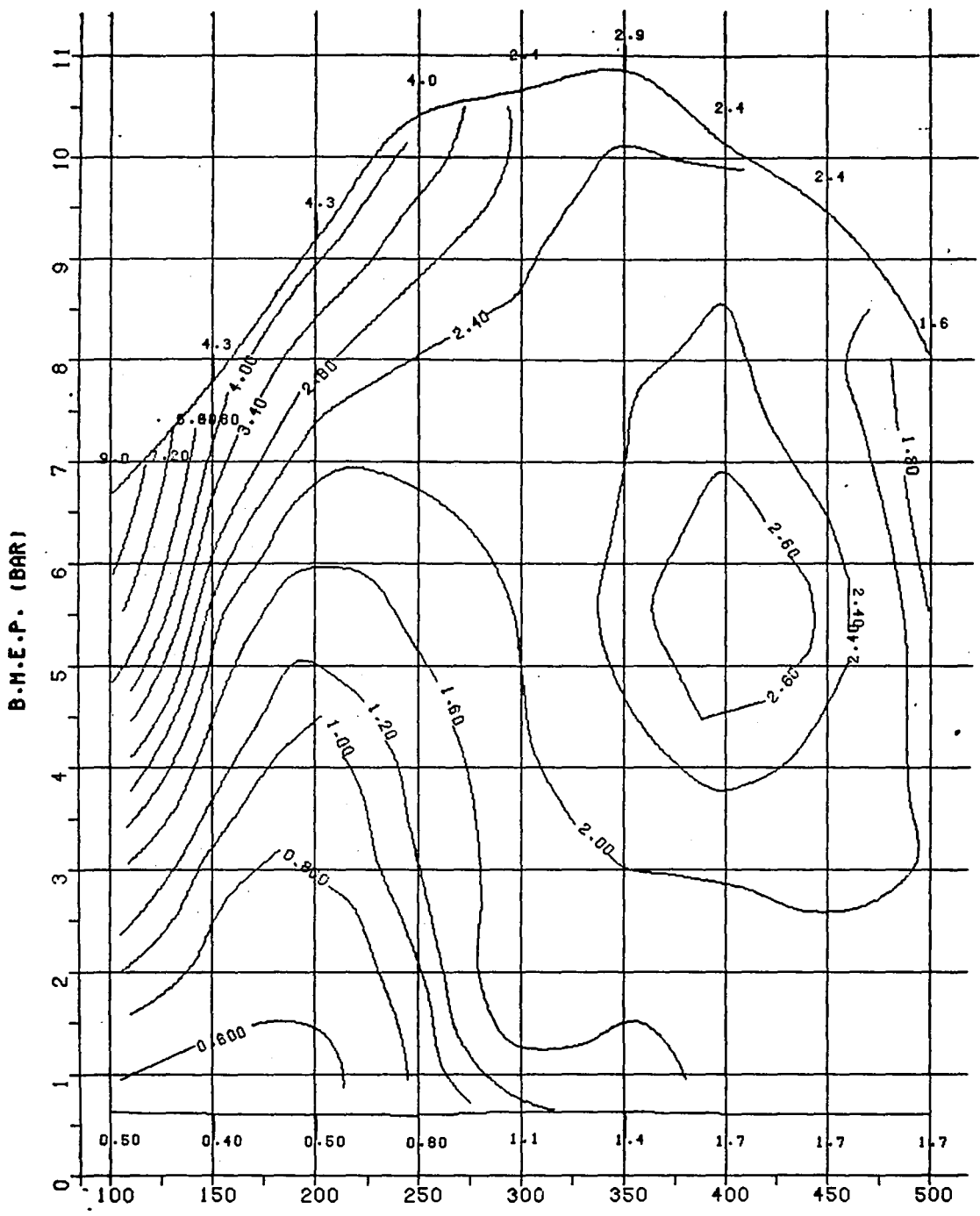

ENGINE SPEED (10 RPM)

SMOKE (BOSCH NUMBER)

70 HP TC DIESEL WITH WATER INJECTION

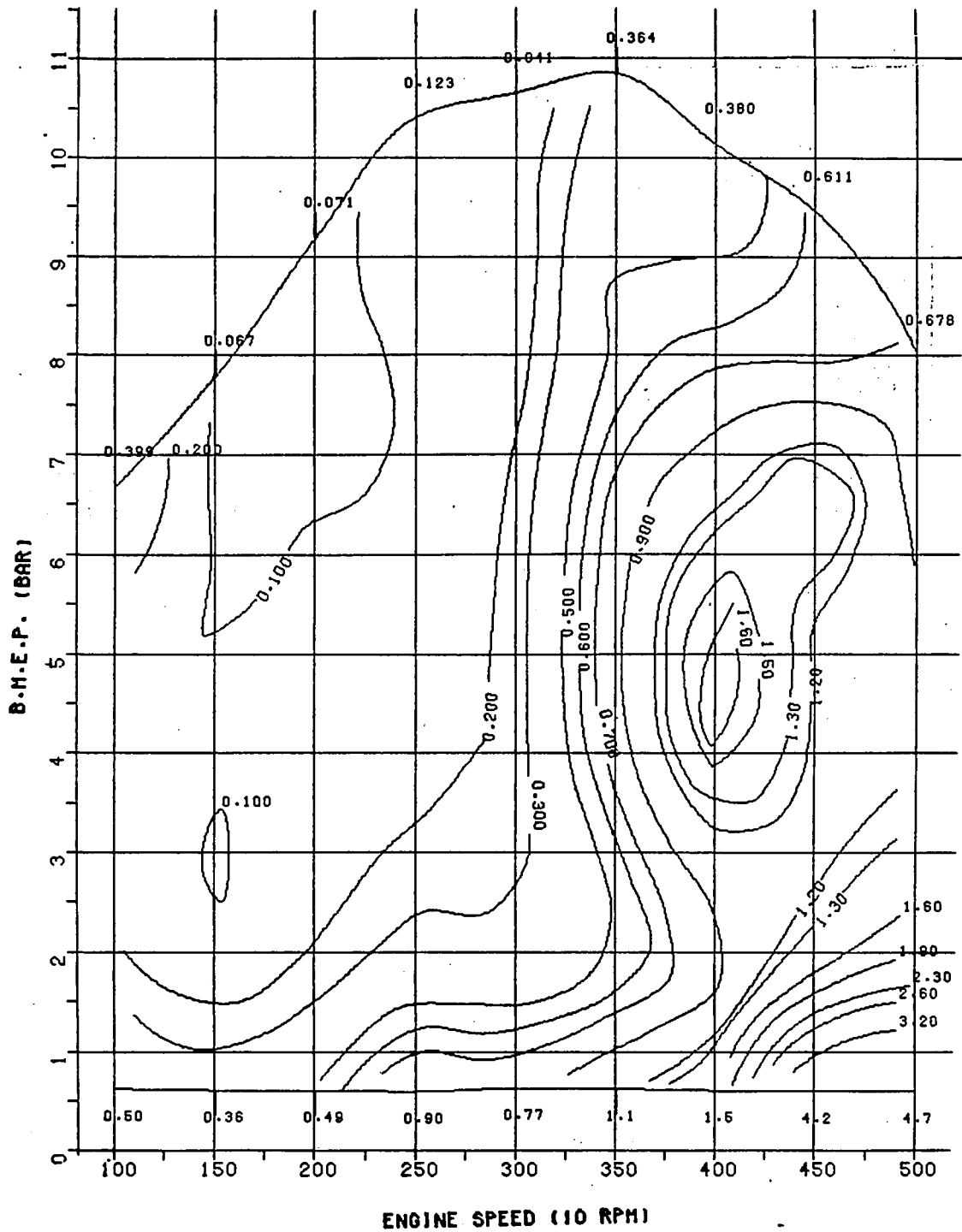

HC EMISSION (G/KWH)
70 HP TC DIESEL WITH WATER INJECTION

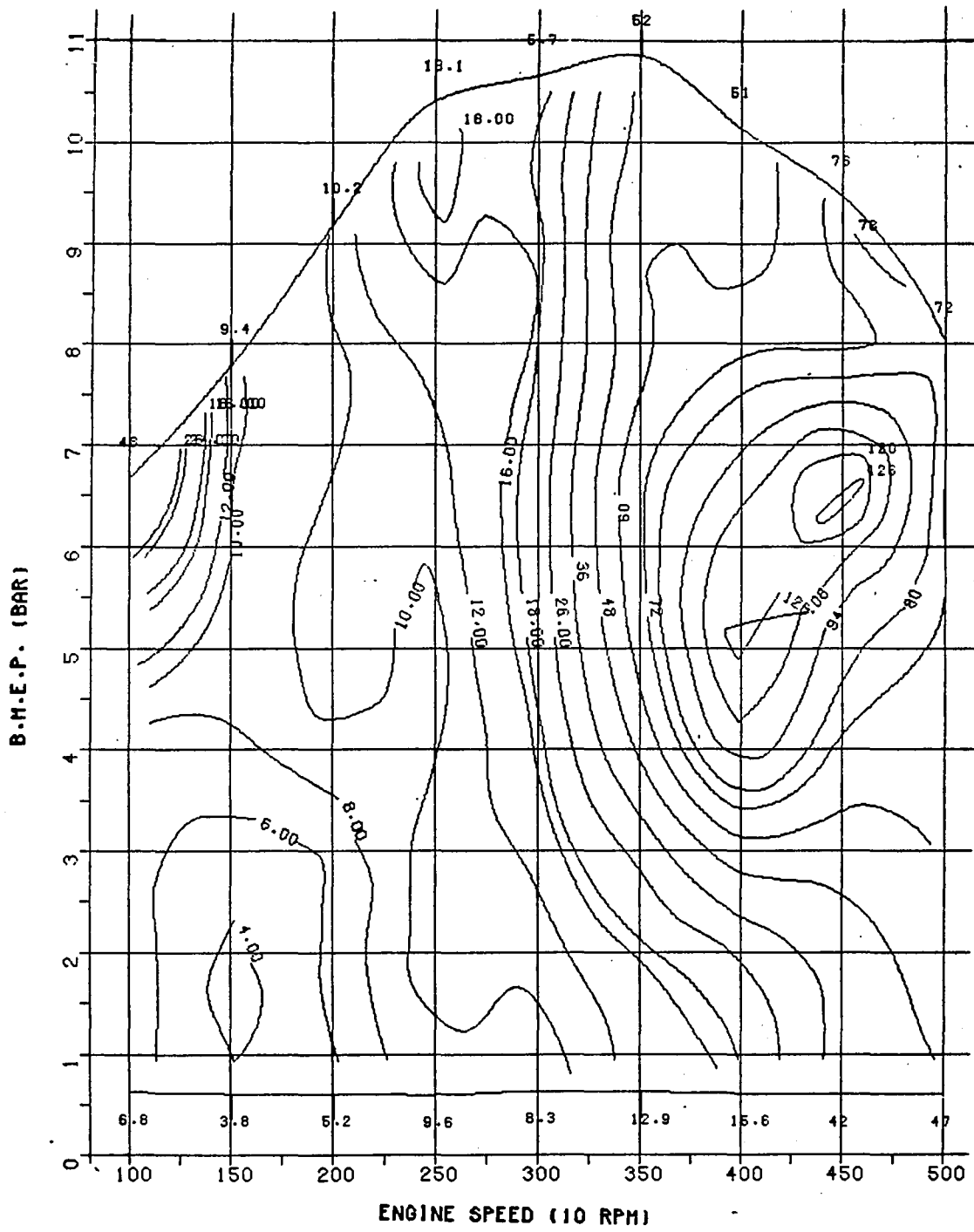

HC CONCENTRATION (PPM)
70 HP TC DIESEL WITH WATER INJECTION

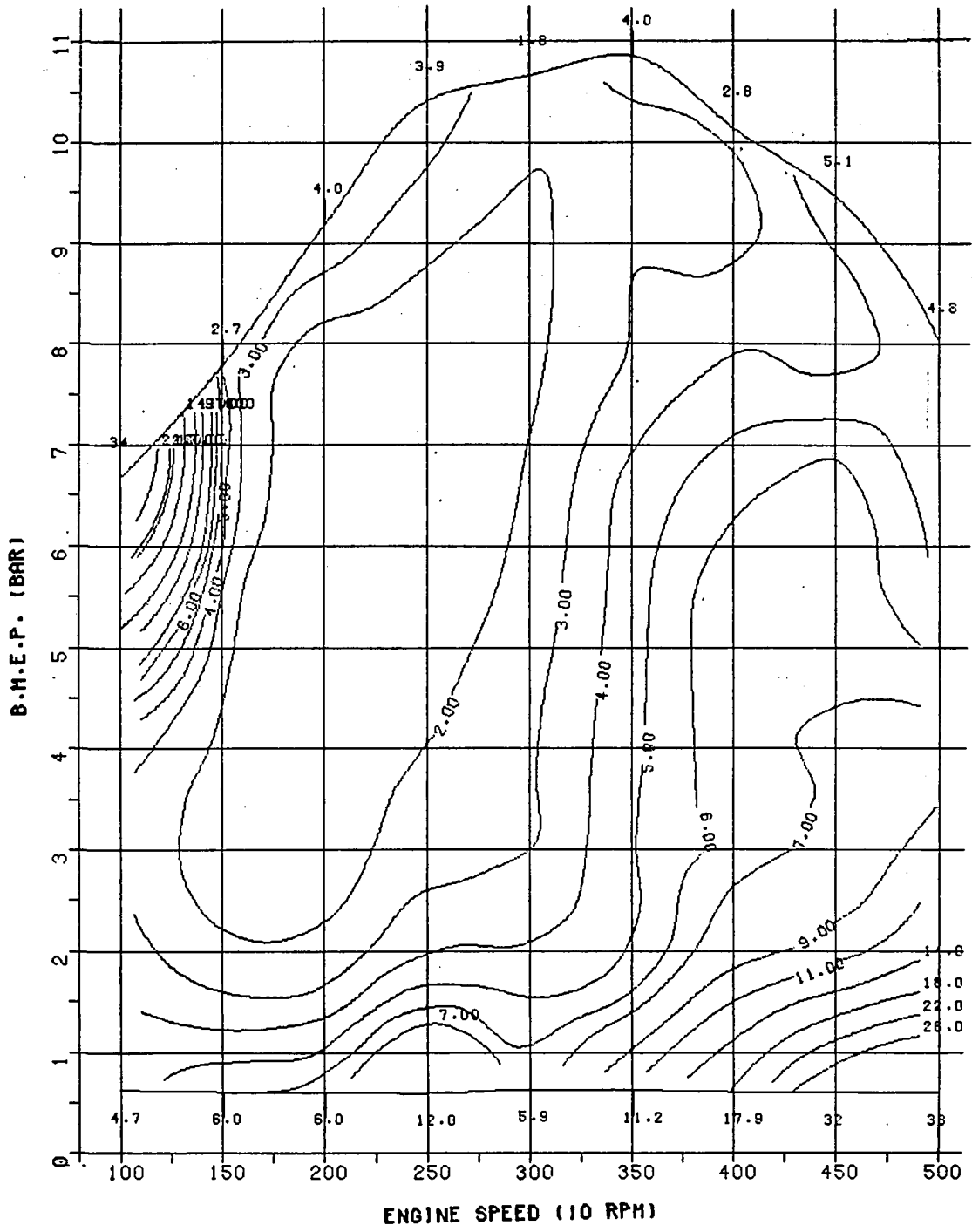

CO EMISSION (G/KWH)
70 HP TC DIESEL WITH WATER INJECTION

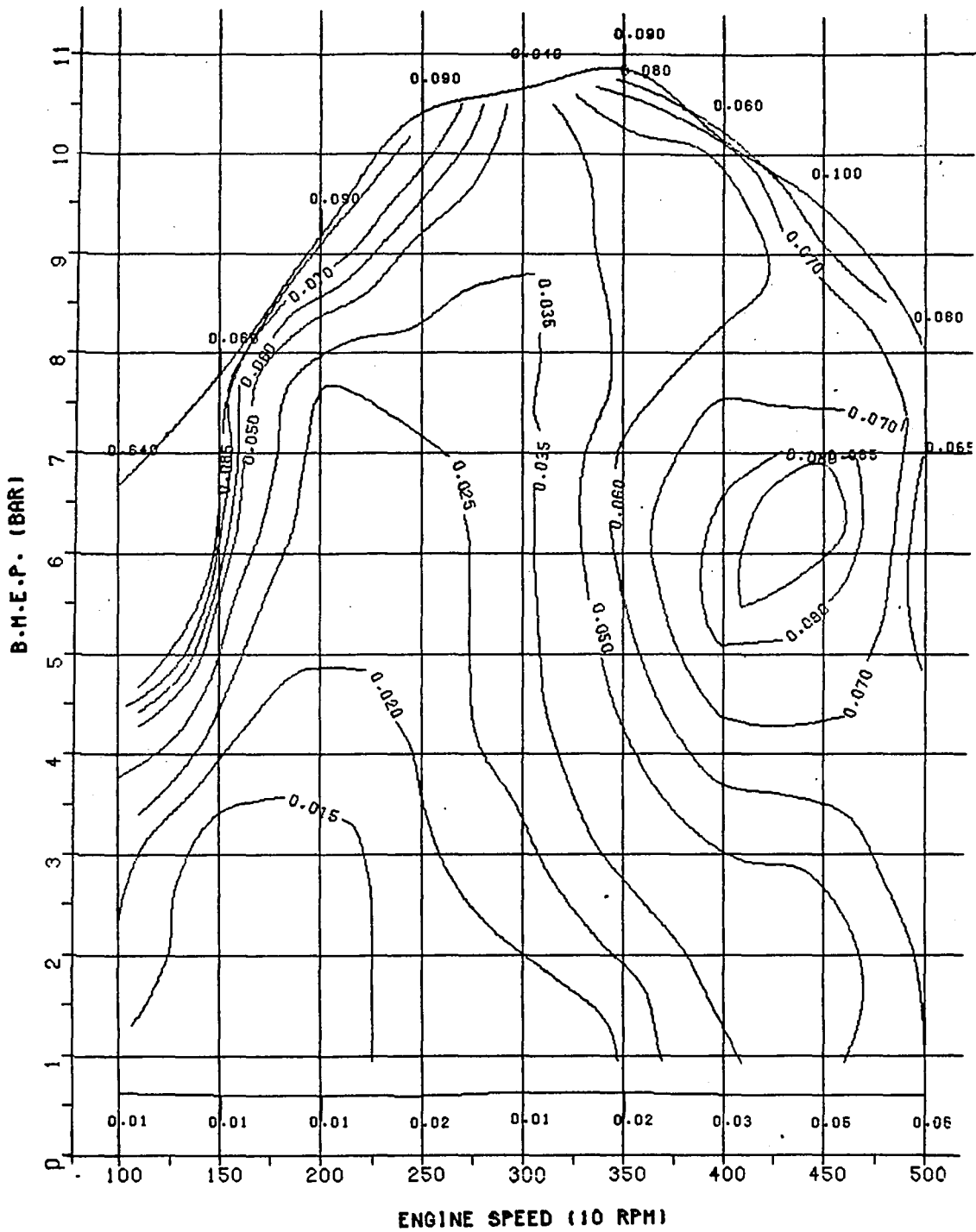

CO CONCENTRATION (%)
70 HP TC DIESEL WITH WATER INJECTION

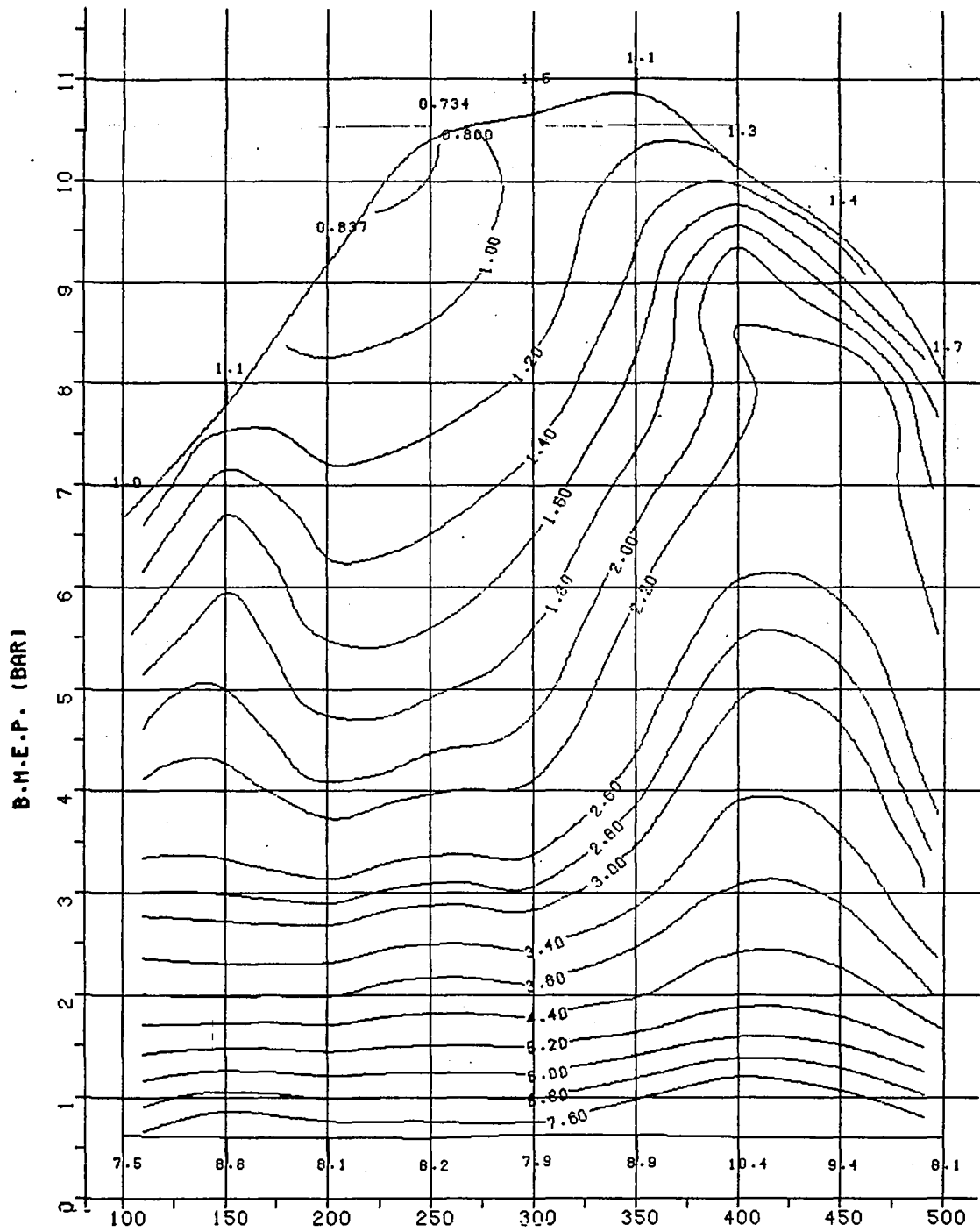

ENGINE SPEED (10 RPM)

NO EMISSION (G/KWH)
70 HP TC DIESEL WITH WATER INJECTION

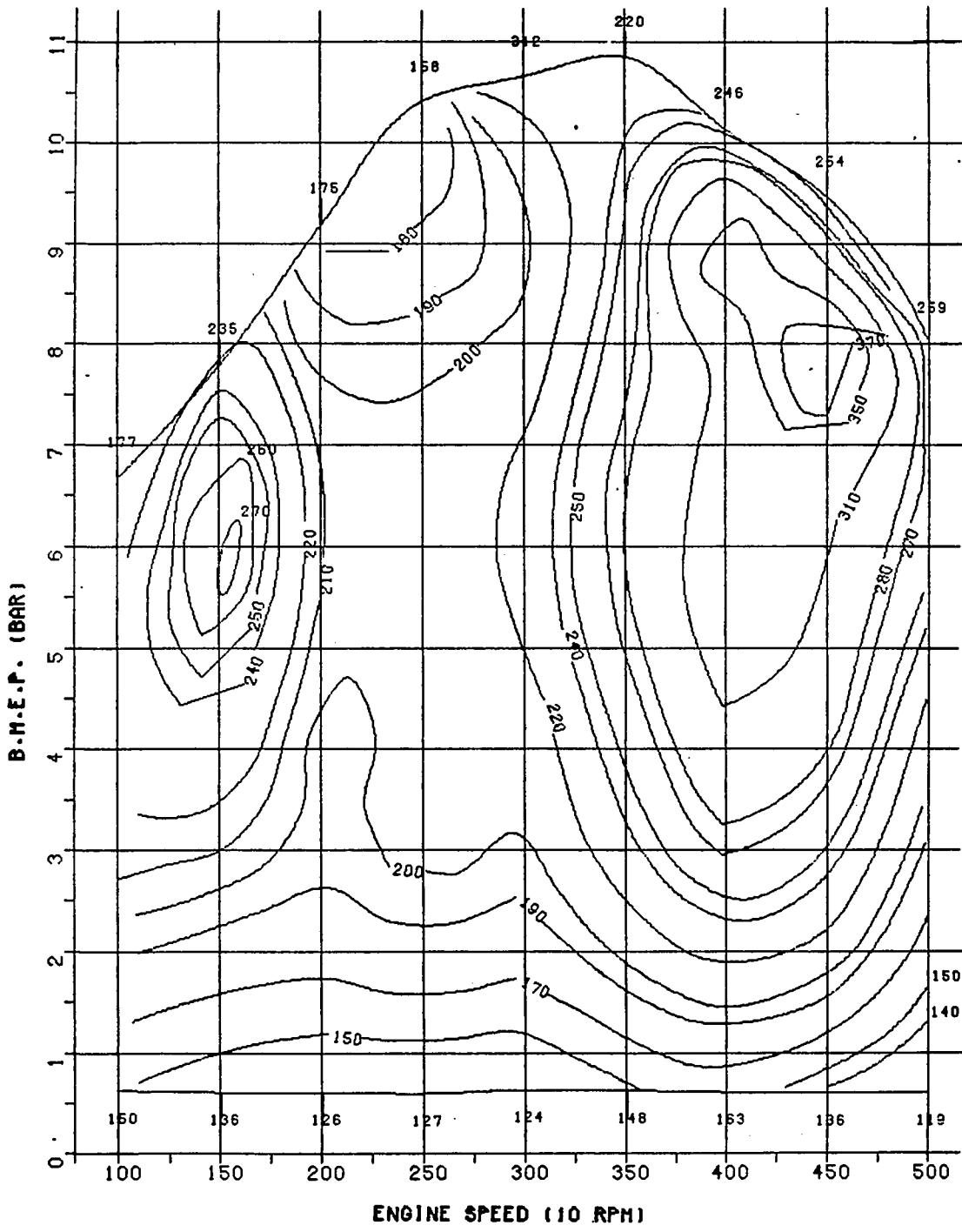

NO CONCENTRATION (PPM)

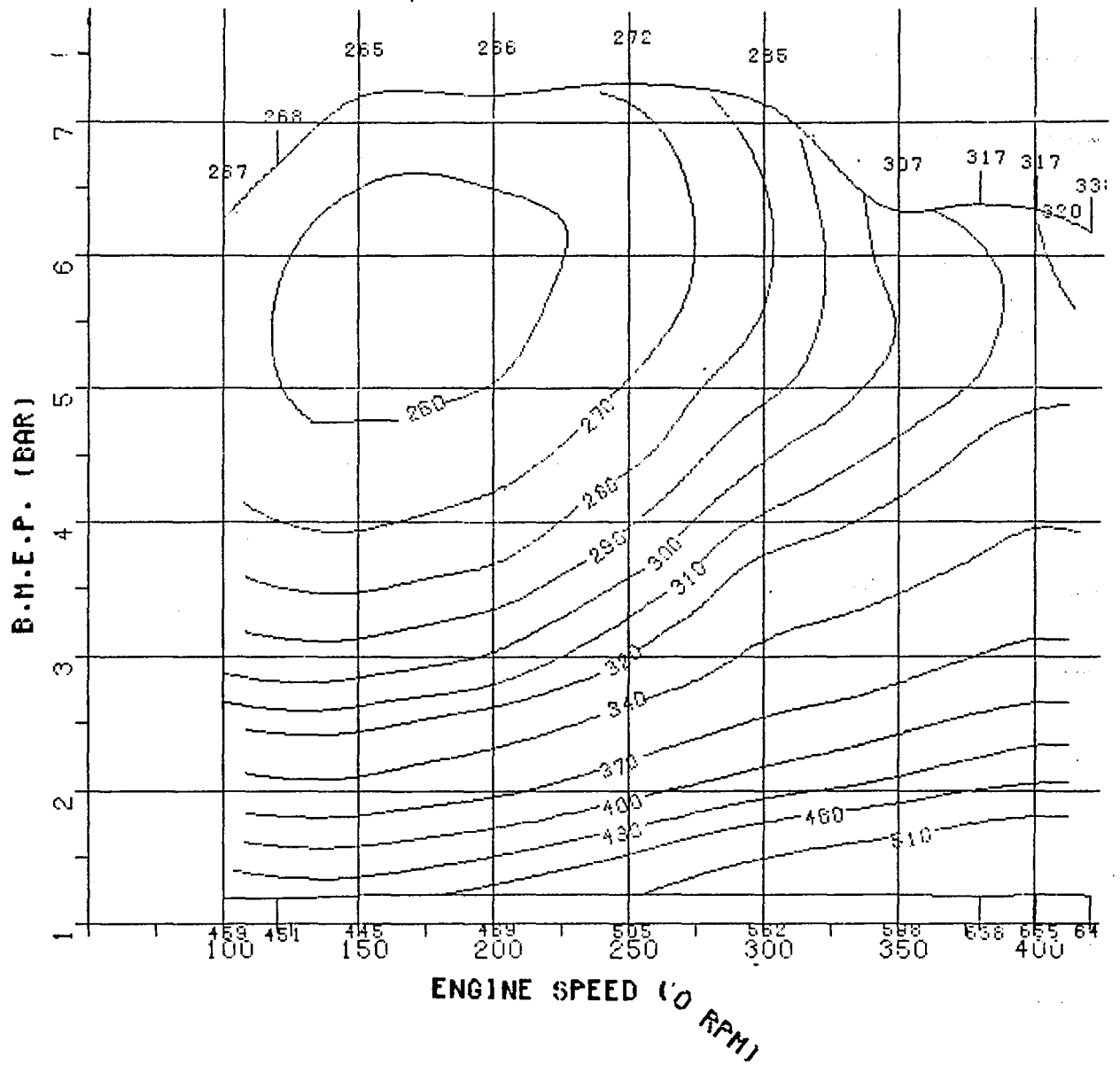

SPECIFIC FUEL CONSUMPTION (G/KWH)
 5 CYLINDER 130 CID N.A. DIESEL ENGINE

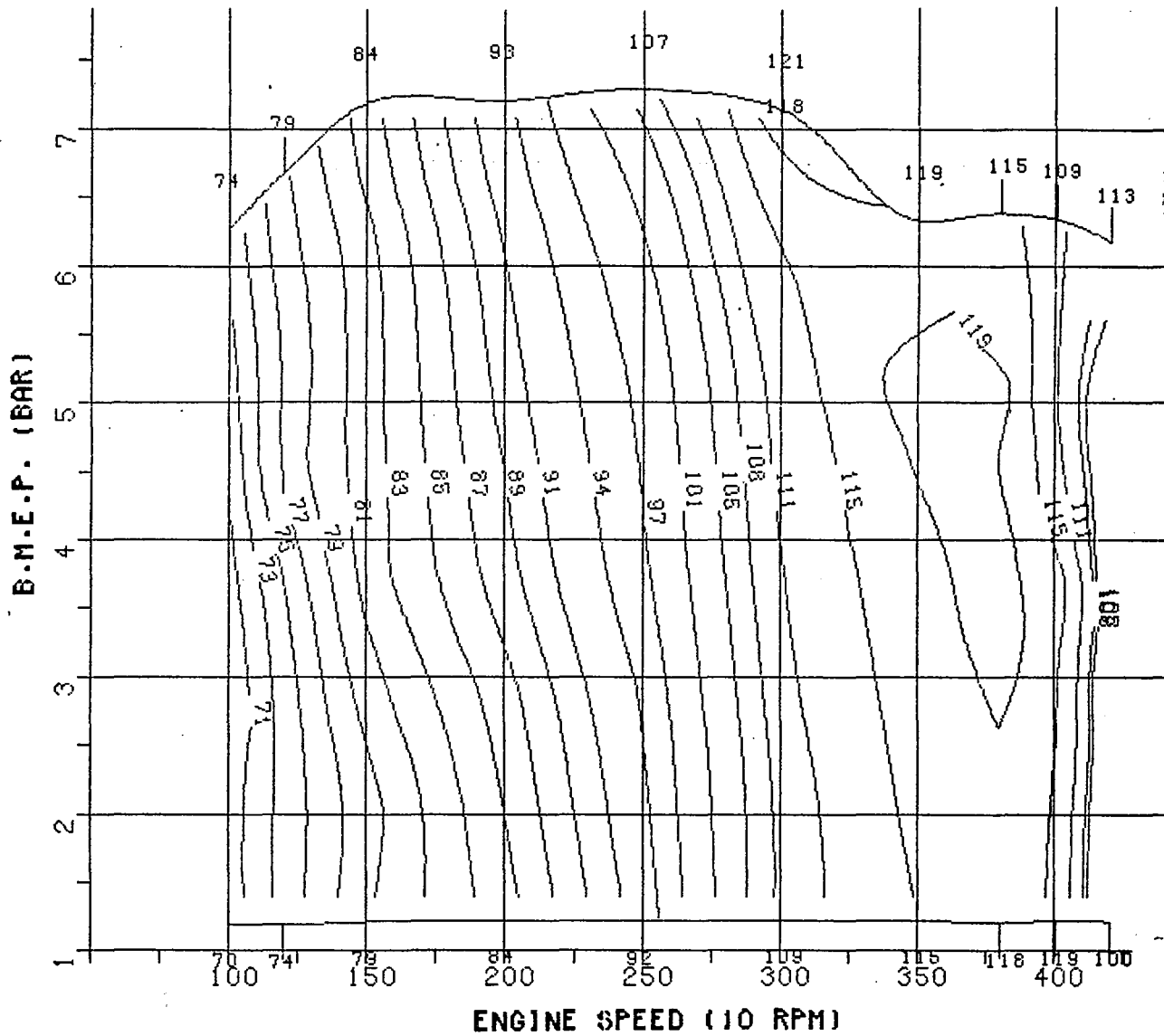

OIL TEMPERATURE (CELSIUS)
 5 CYLINDER 130 CID N.A. DIESEL ENGINE

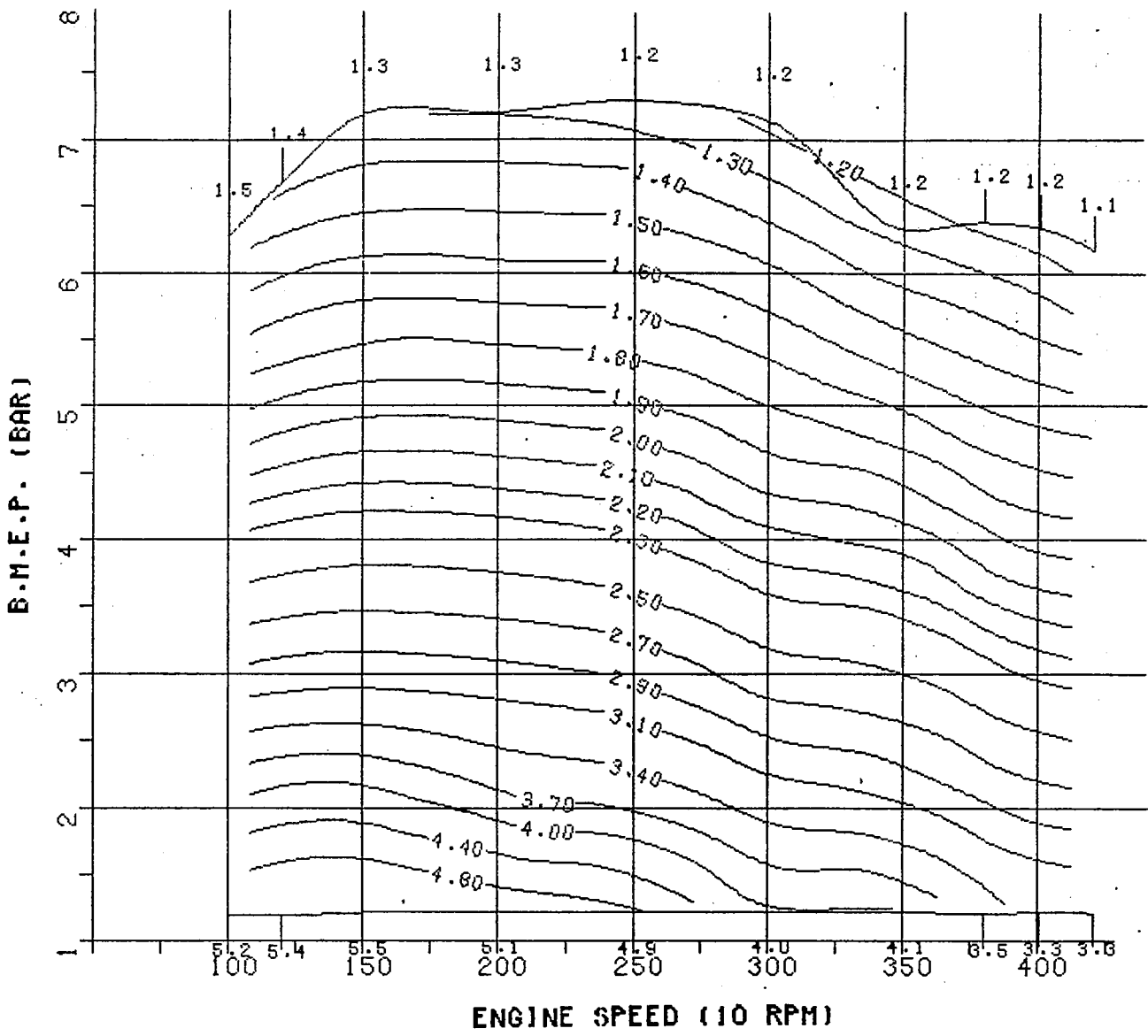

AIR TO FUEL RATIO
 5 CYLINDER 130 CID N.A. DIESEL ENGINE

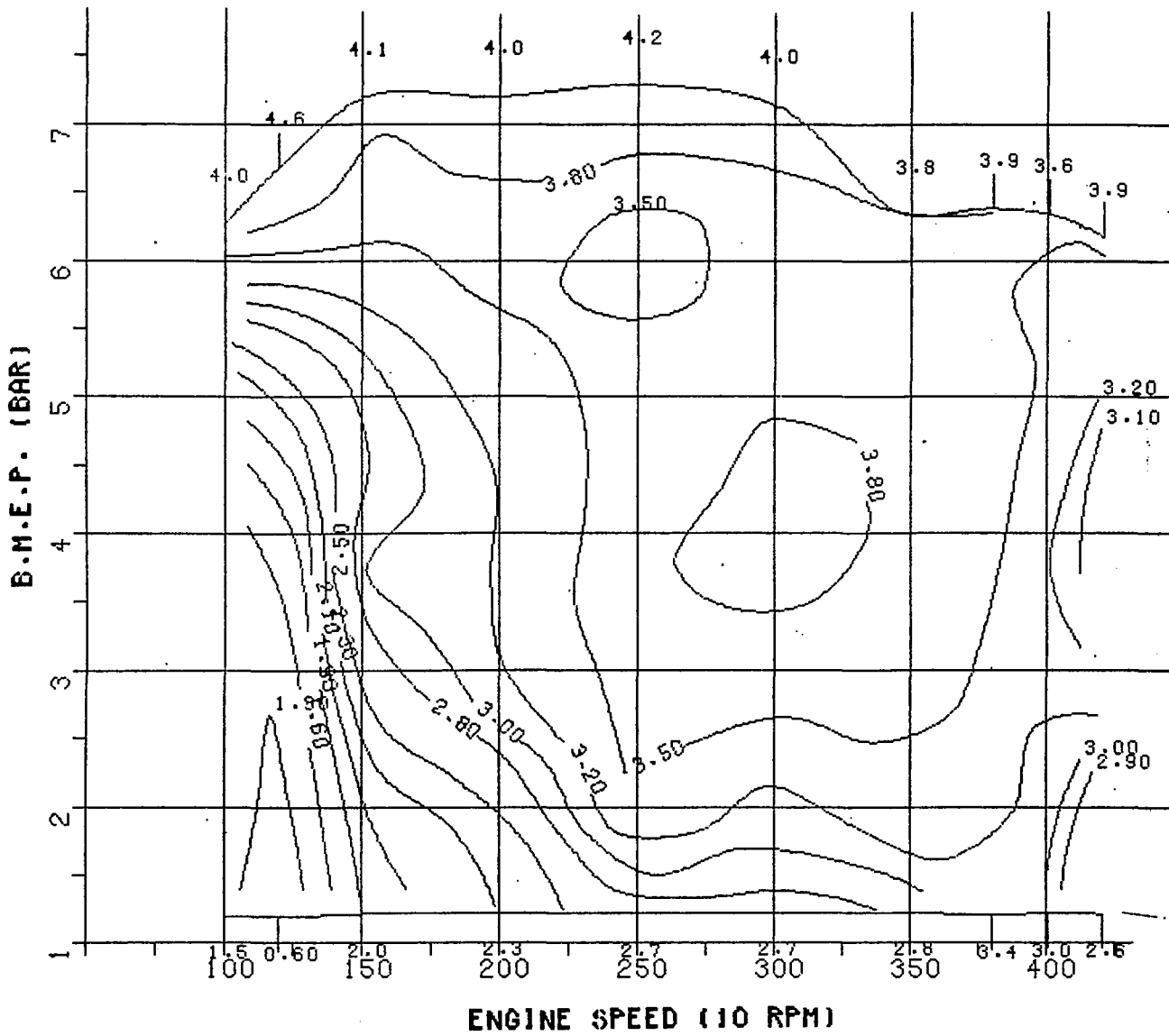

SMOKE (BOSCH NUMBER)
 5 CYLINDER 130 CID N.A. DIESEL ENGINE

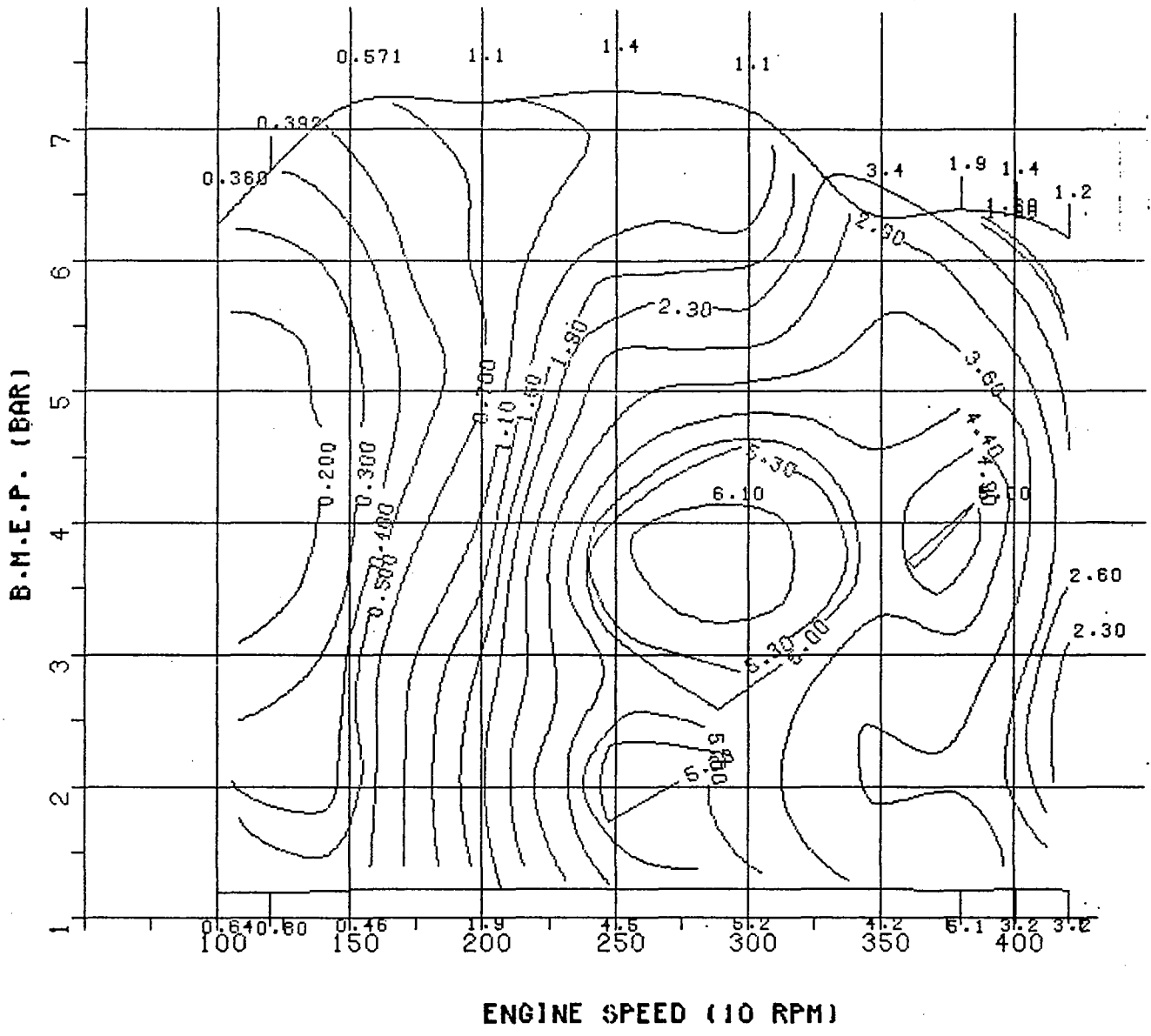

HC EMISSION (G/KWH)
 5 CYLINDER 130 CID N.A. DIESEL ENGINE

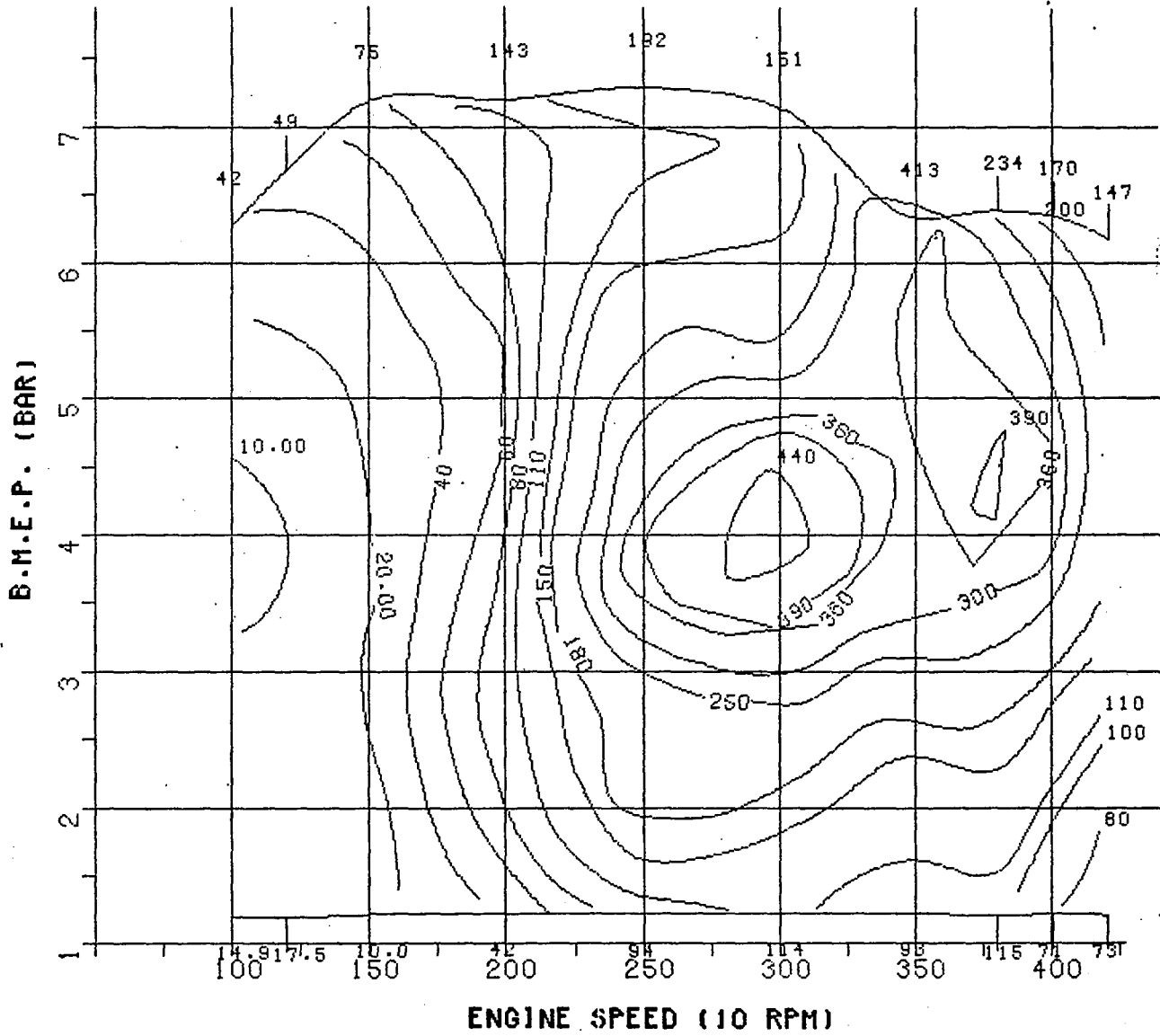

HC CONCENTRATION (PPM)
 5 CYLINDER 130 CID N.A. DIESEL ENGINE

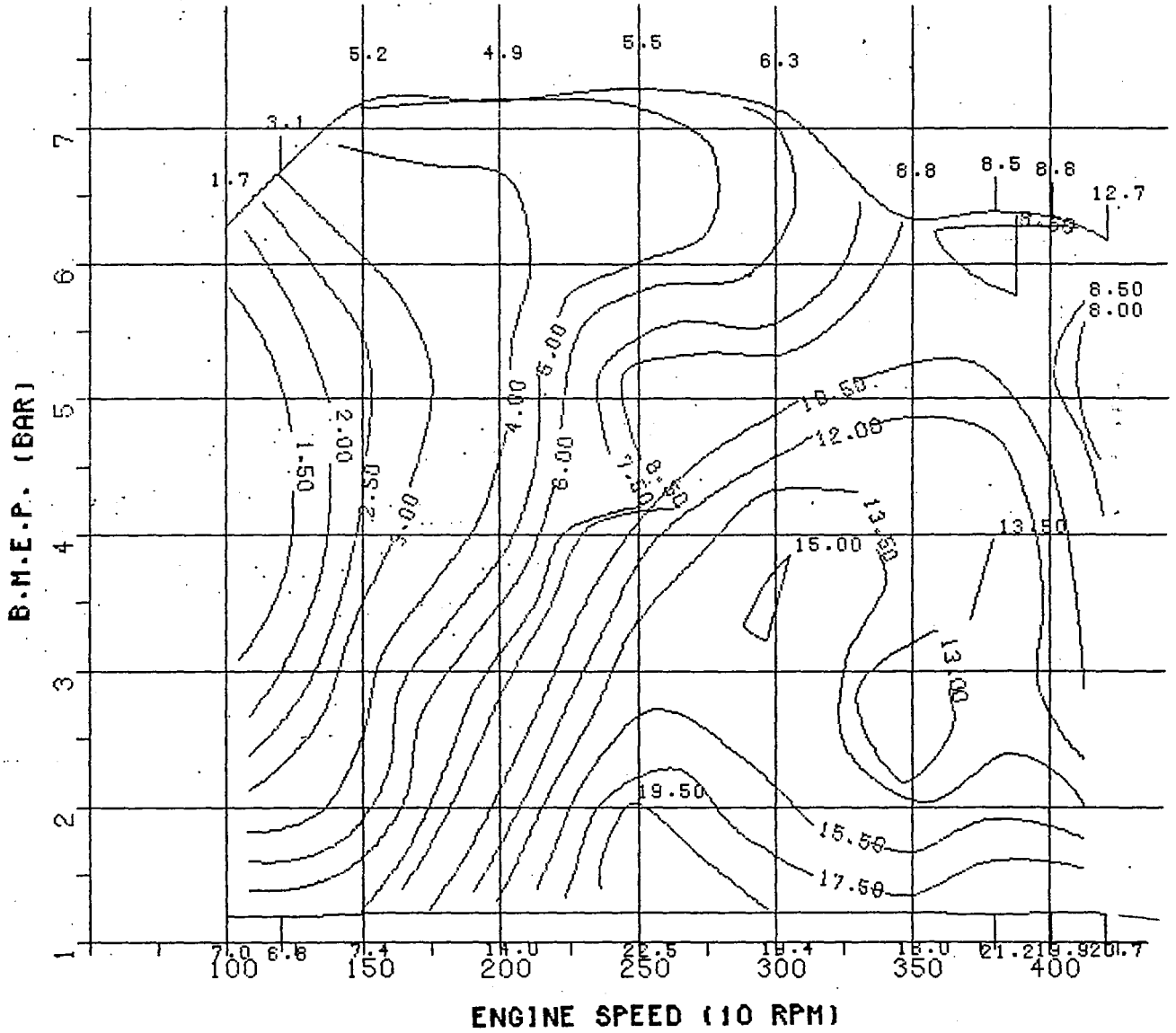

CO EMISSION (G/KWH)
 5 CYLINDER 130 CID N.A. DIESEL ENGINE

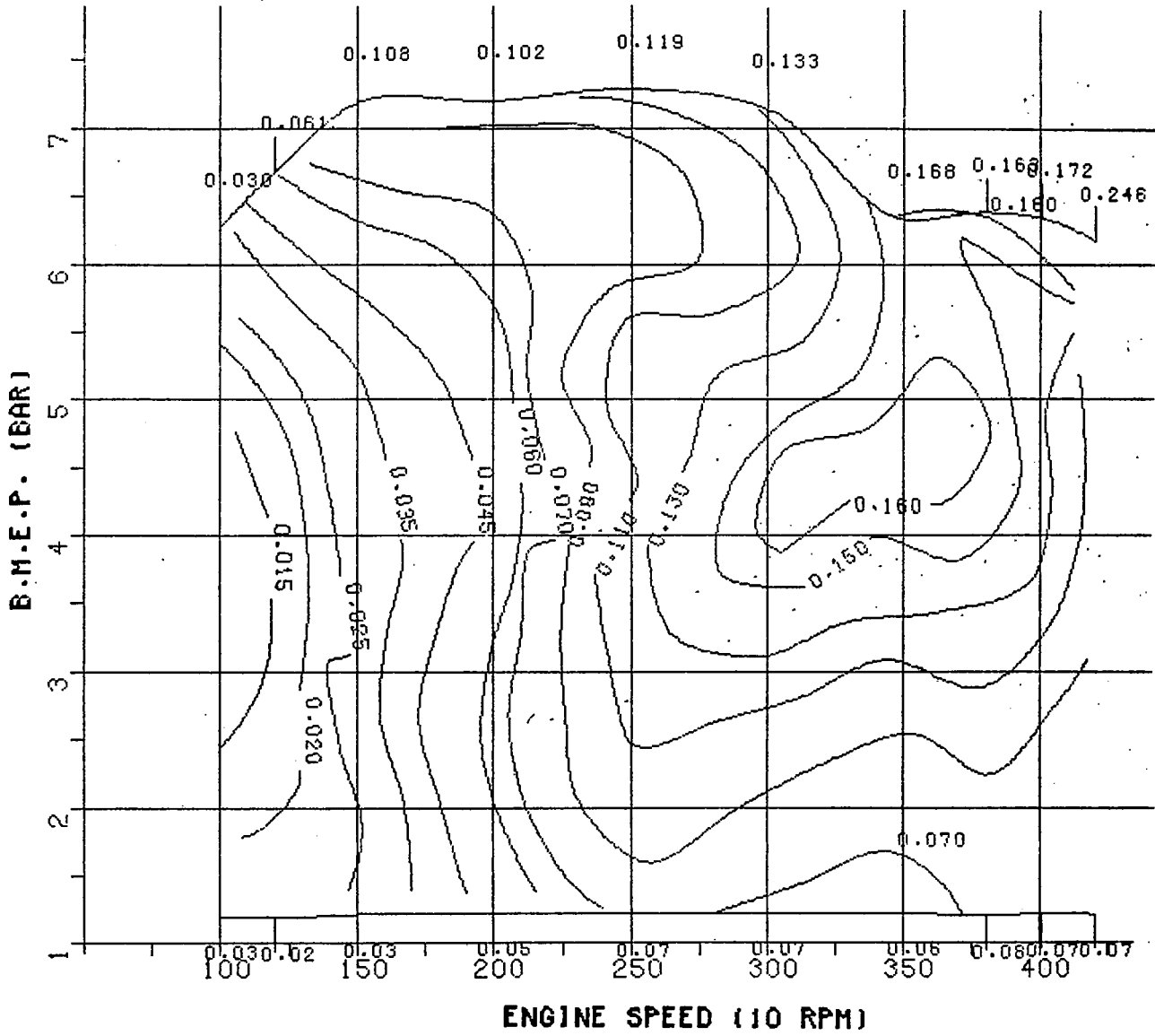

CO CONCENTRATION (%)
 5 CYLINDER 130 CID N-A. DIESEL ENGINE

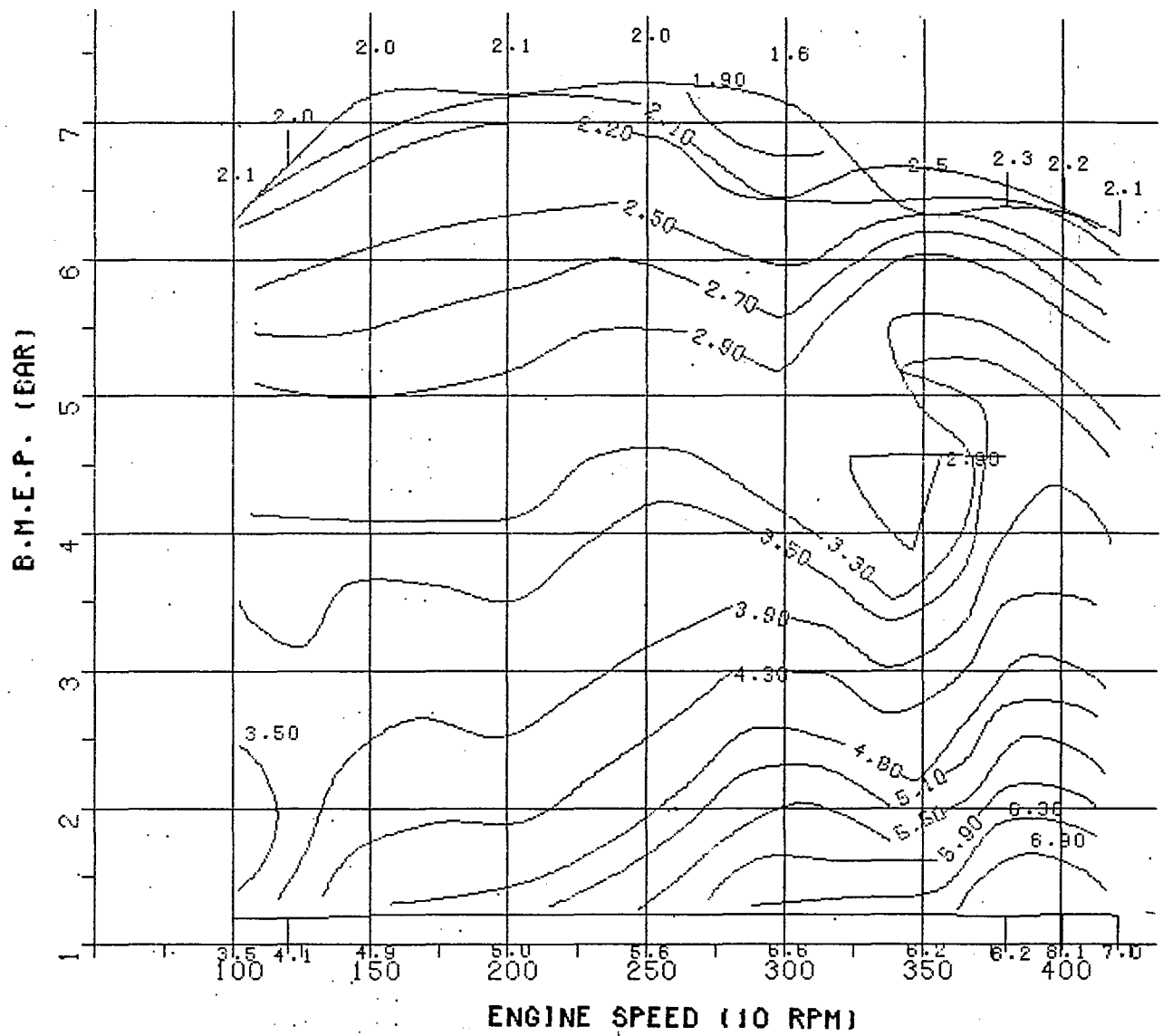

NO. EMISSION (G/KWH)
 5 CYLINDER 130 CID N.A. DIESEL ENGINE

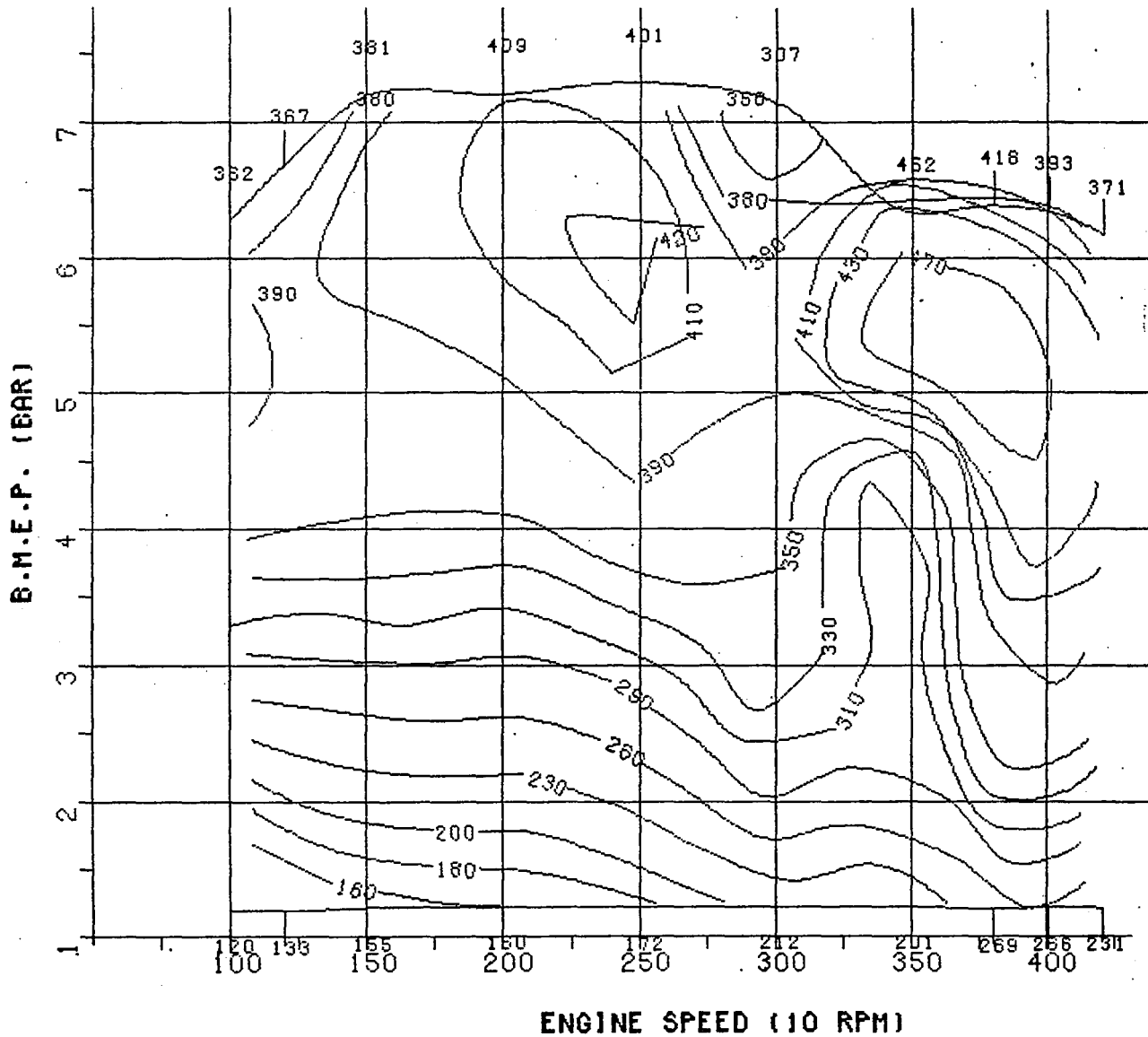

NO CONCENTRATION (PPM)
 5 CYLINDER 130 CID N.A. DIESEL ENGINE

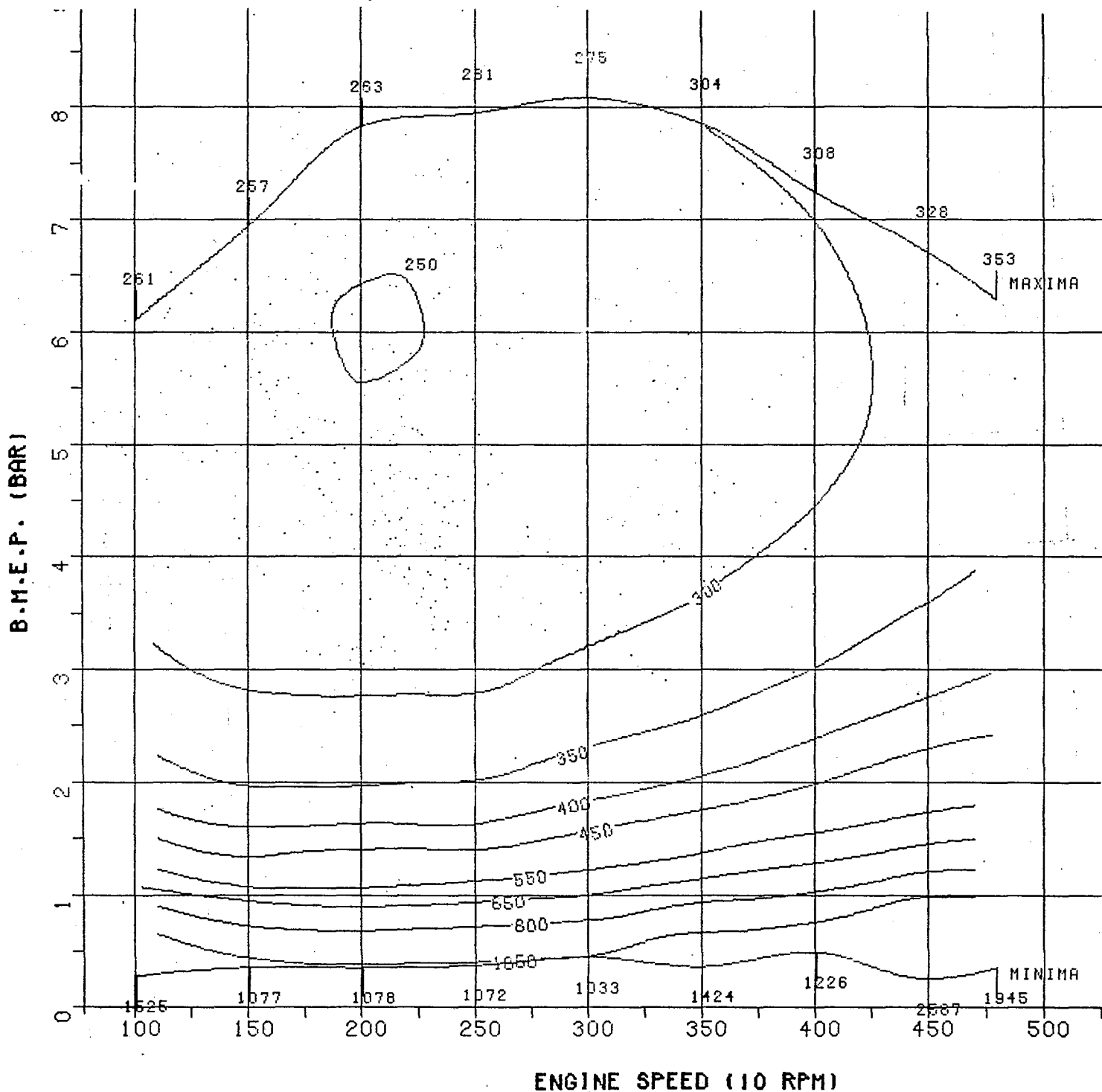

SPECIFIC FUEL CONSUMPTION (G/KWH)
6 CYLINDER 146 CID N.A. DIESEL ENGINE

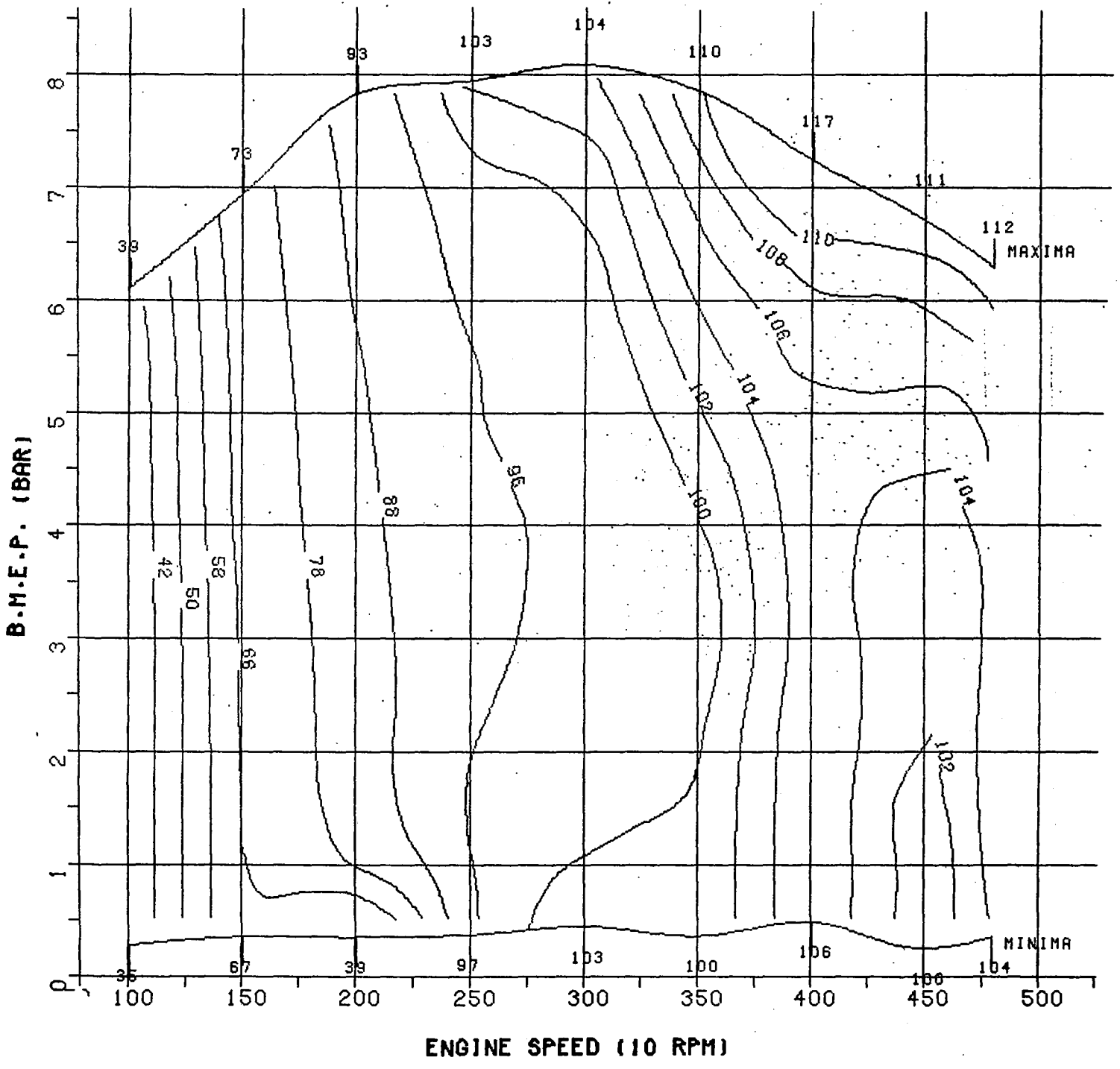

OIL TEMPERATURE (CELSIUS)
 6 CYLINDER 146 CID N.A. DIESEL ENGINE

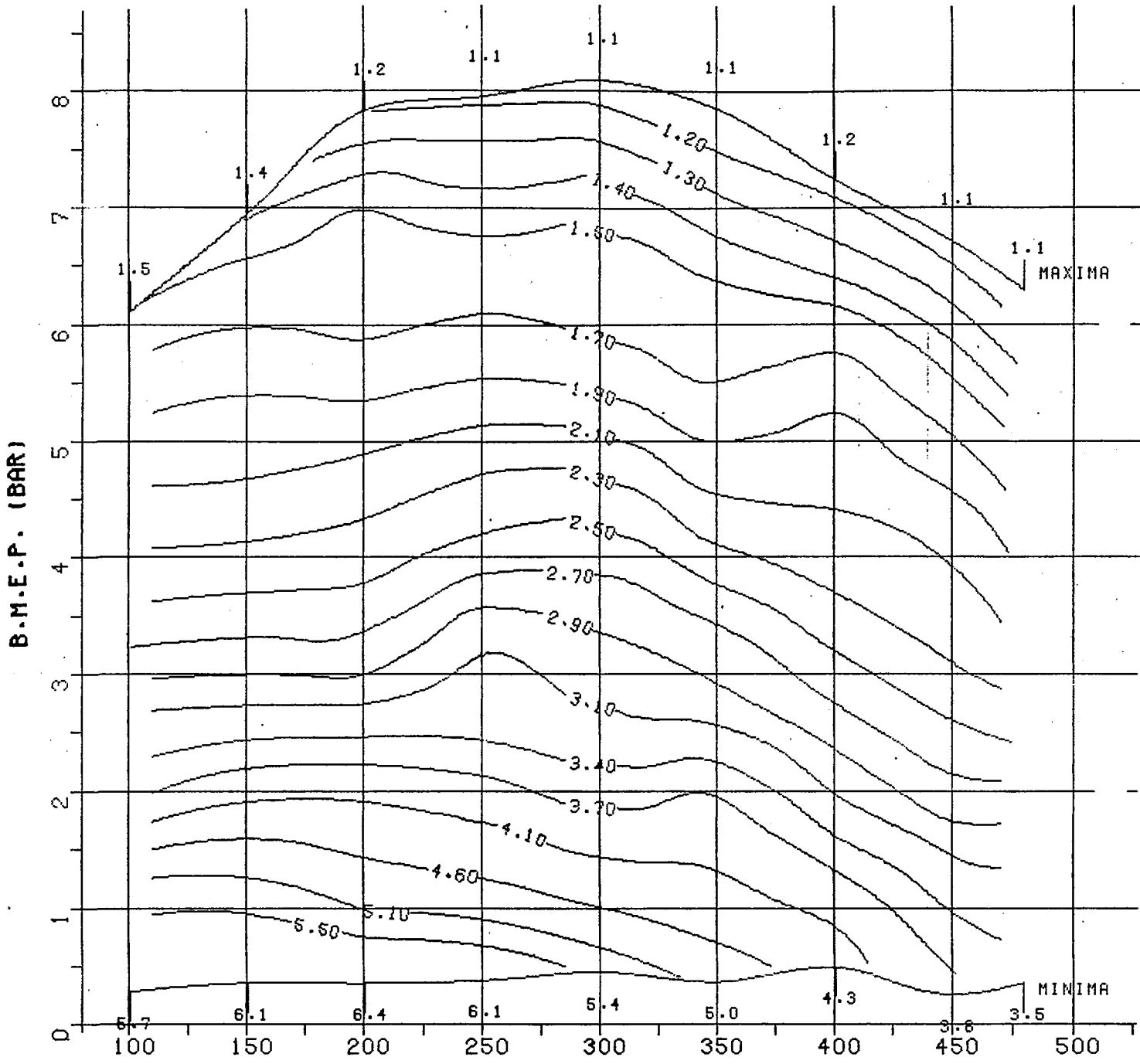

ENGINE SPEED (10 RPM)

AIR TO FUEL RATIO
6 CYLINDER 146 CID N.A. DIESEL ENGINE

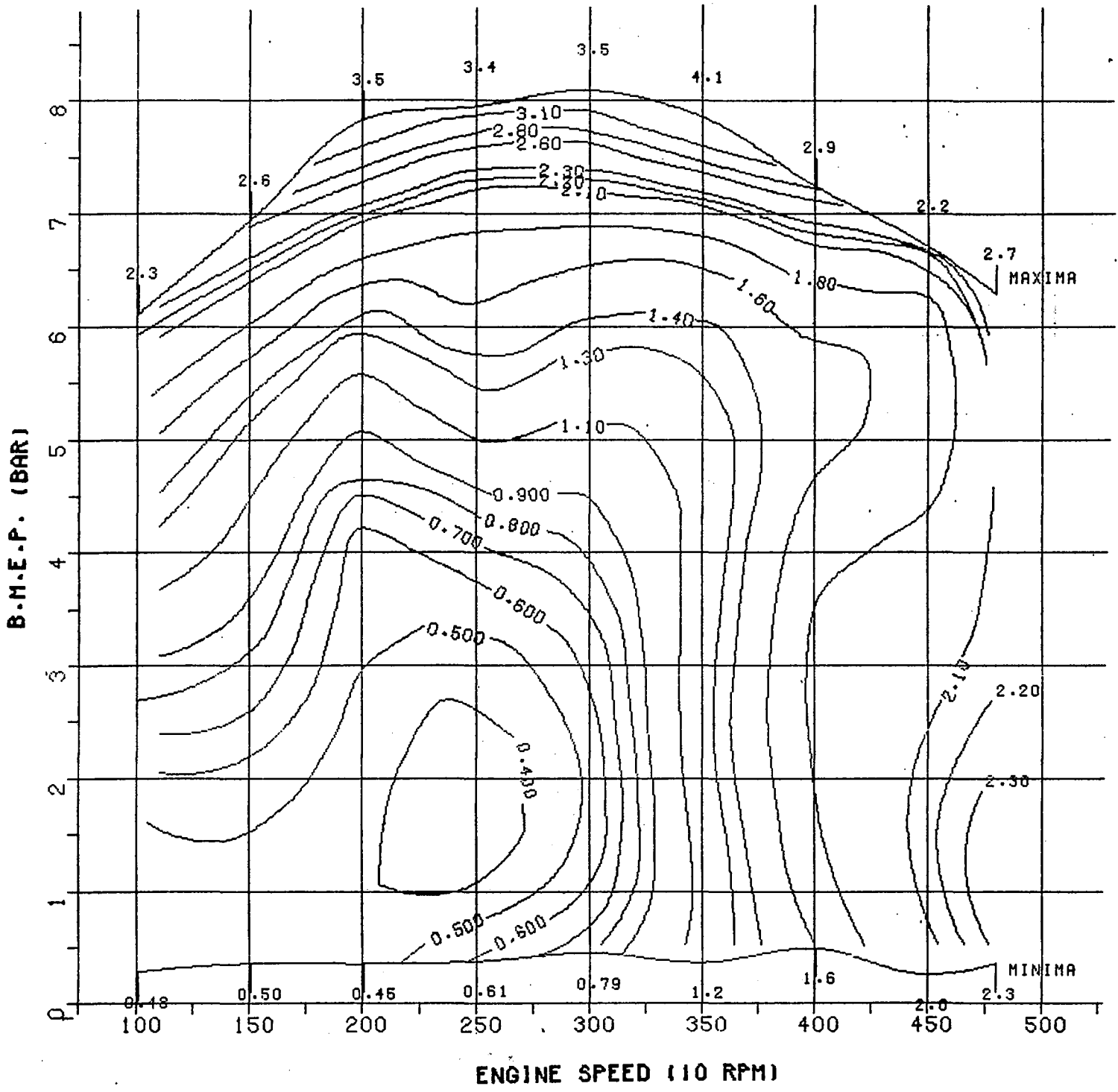

**SMOKE (BOSCH NUMBER)
6 CYLINDER 146 CID N.A. DIESEL ENGINE**

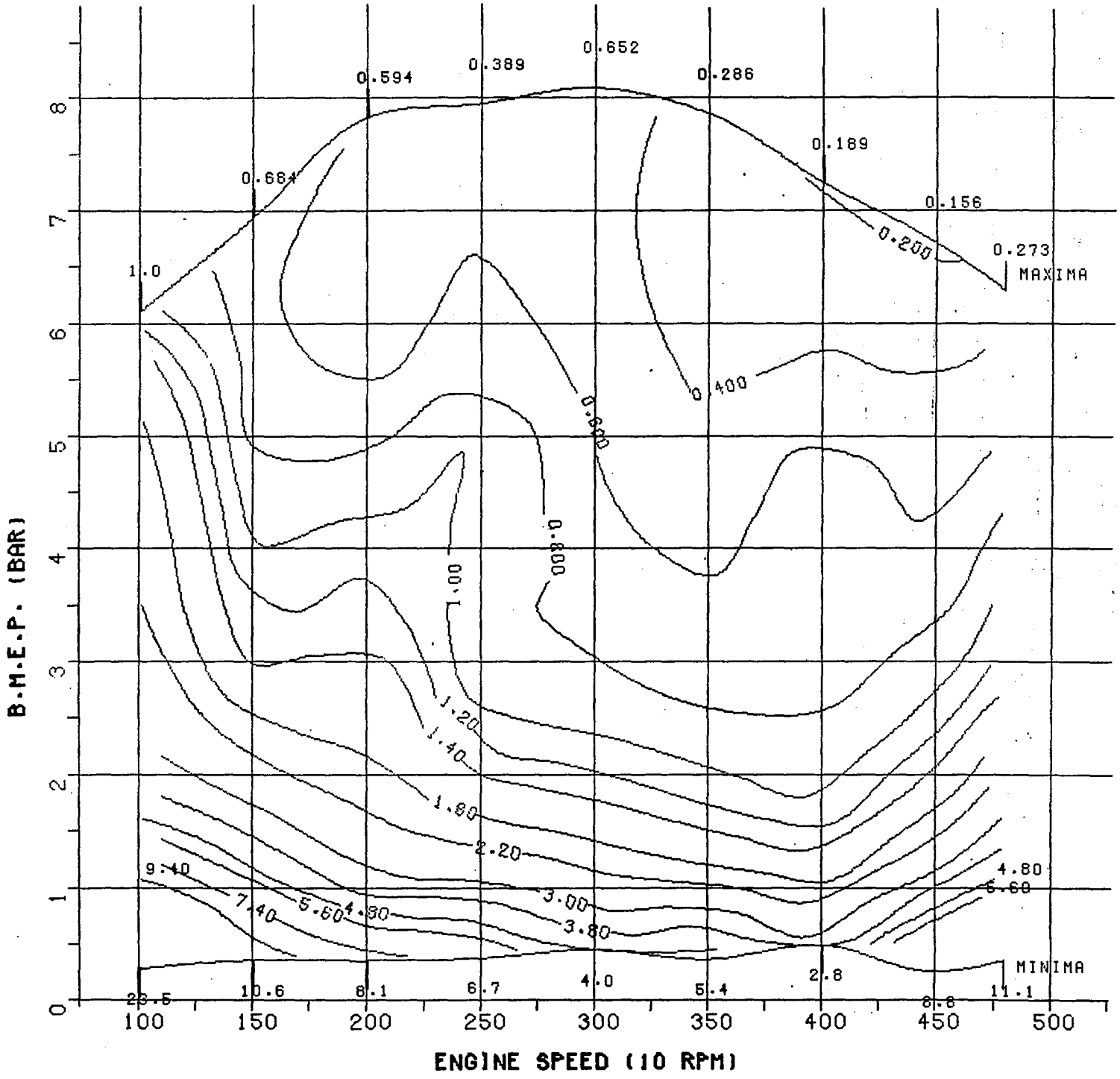

HC EMISSION (G/KWH)
 6 CYLINDER 146 CID N.A. DIESEL ENGINE

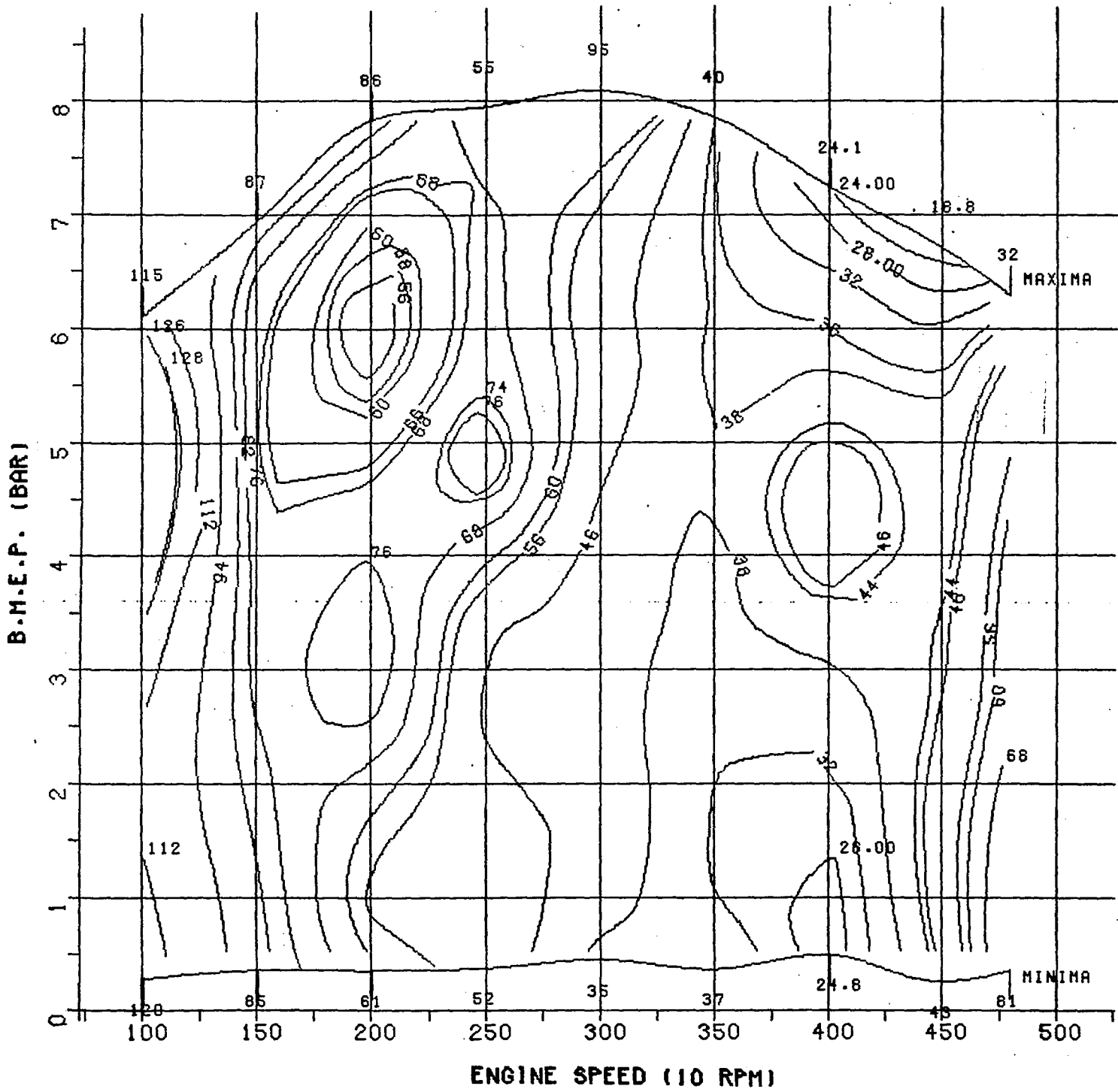

HC CONCENTRATION (PPM)
 6 CYLINDER 146 CID N.A. DIESEL ENGINE

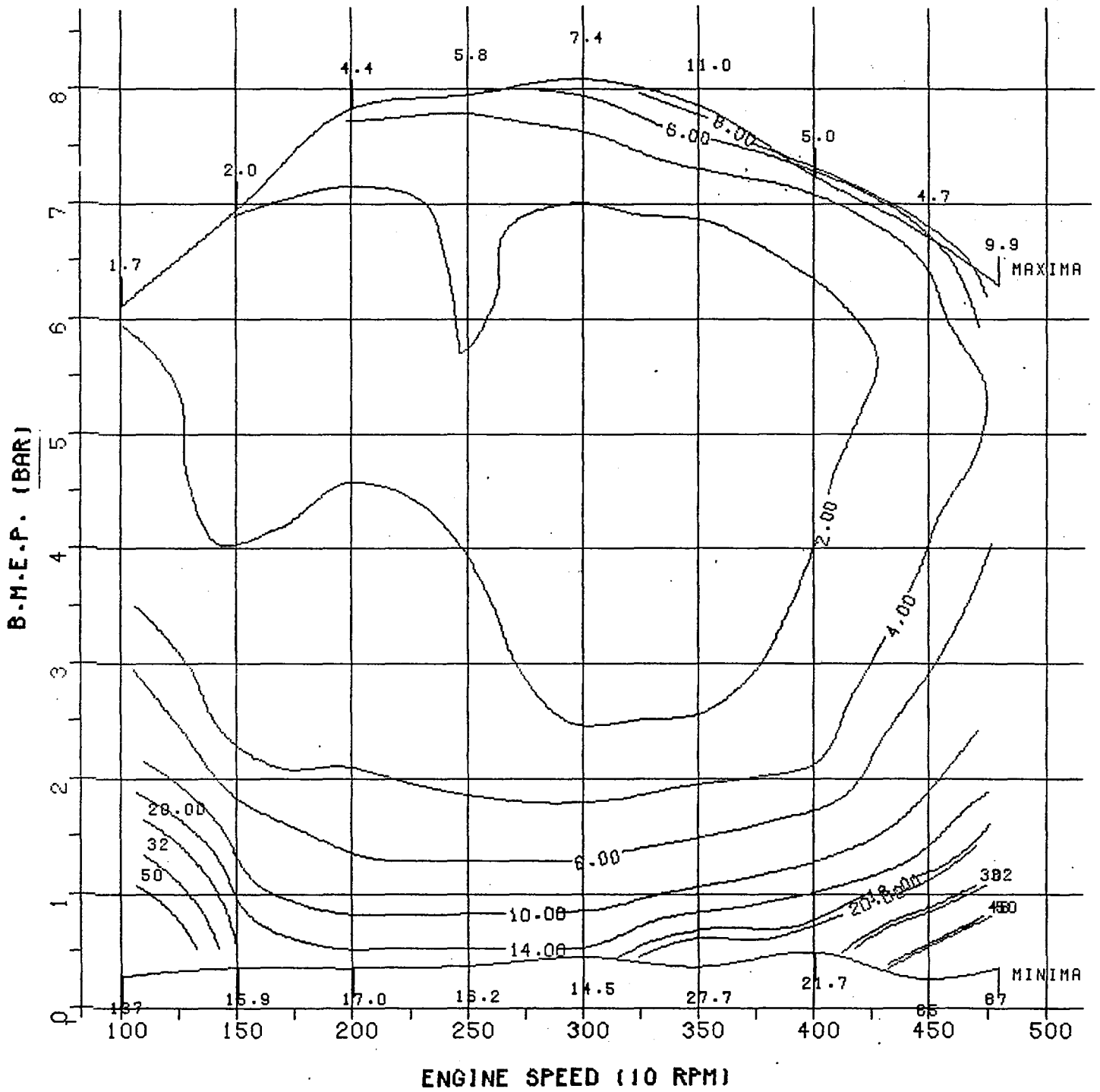

CO EMISSION (G/KWH)
 6 CYLINDER 146 CID N.A. DIESEL ENGINE

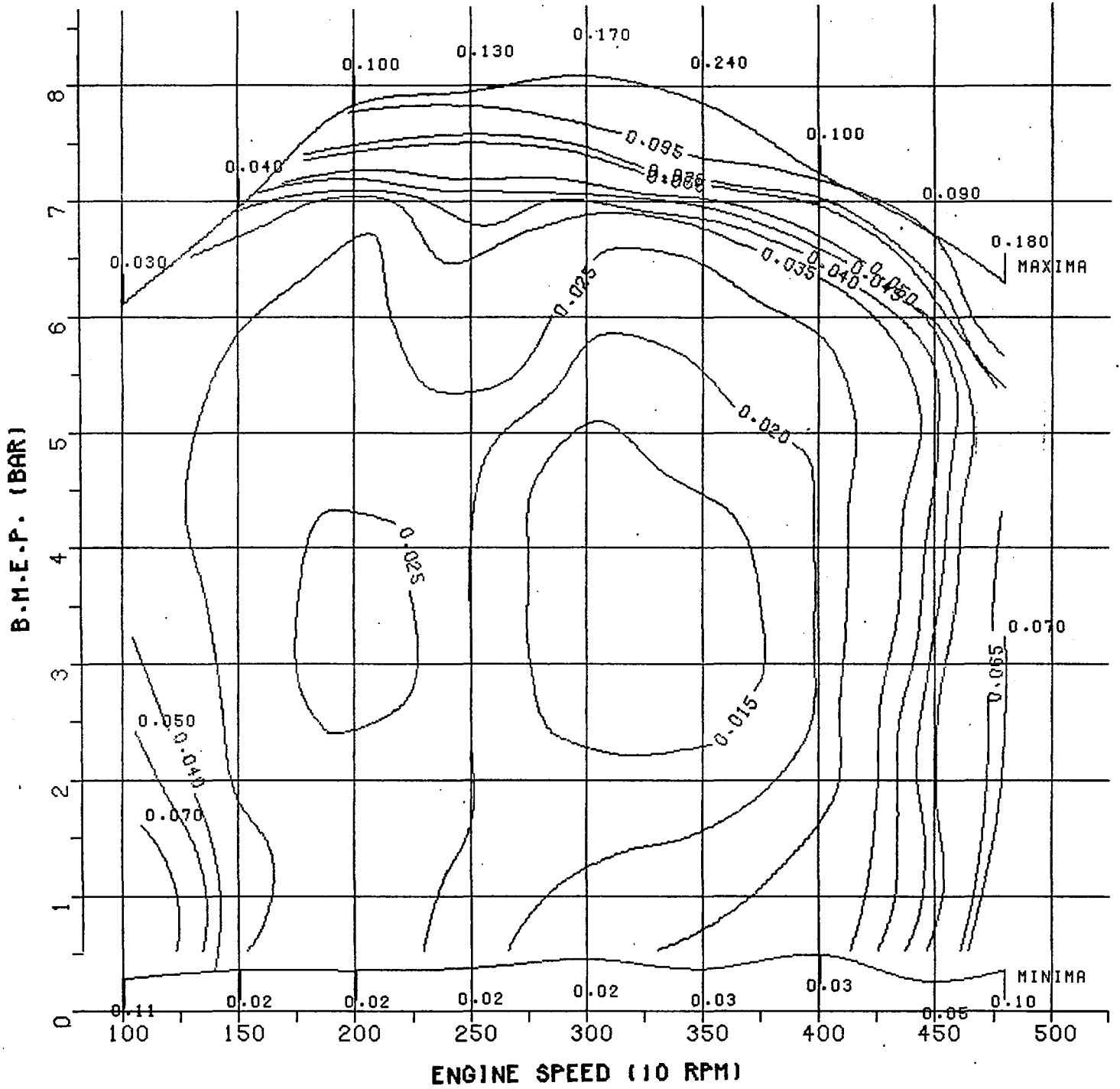

CO CONCENTRATION (%)
 6 CYLINDER 146 CID N.A. DIESEL ENGINE

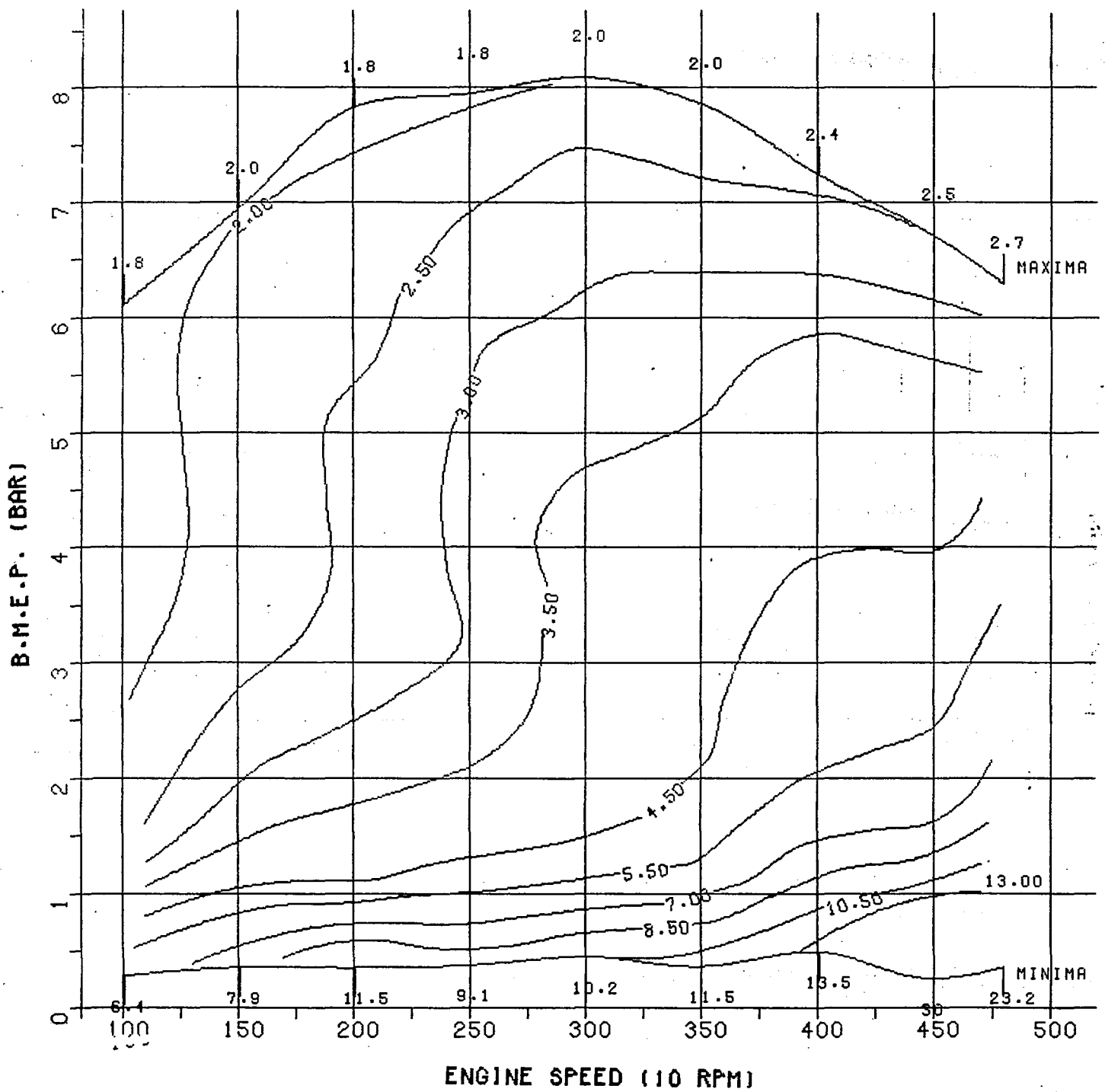

NO. EMISSION (G/KWH)
 6 CYLINDER 146 CID N.A. DIESEL ENGINE

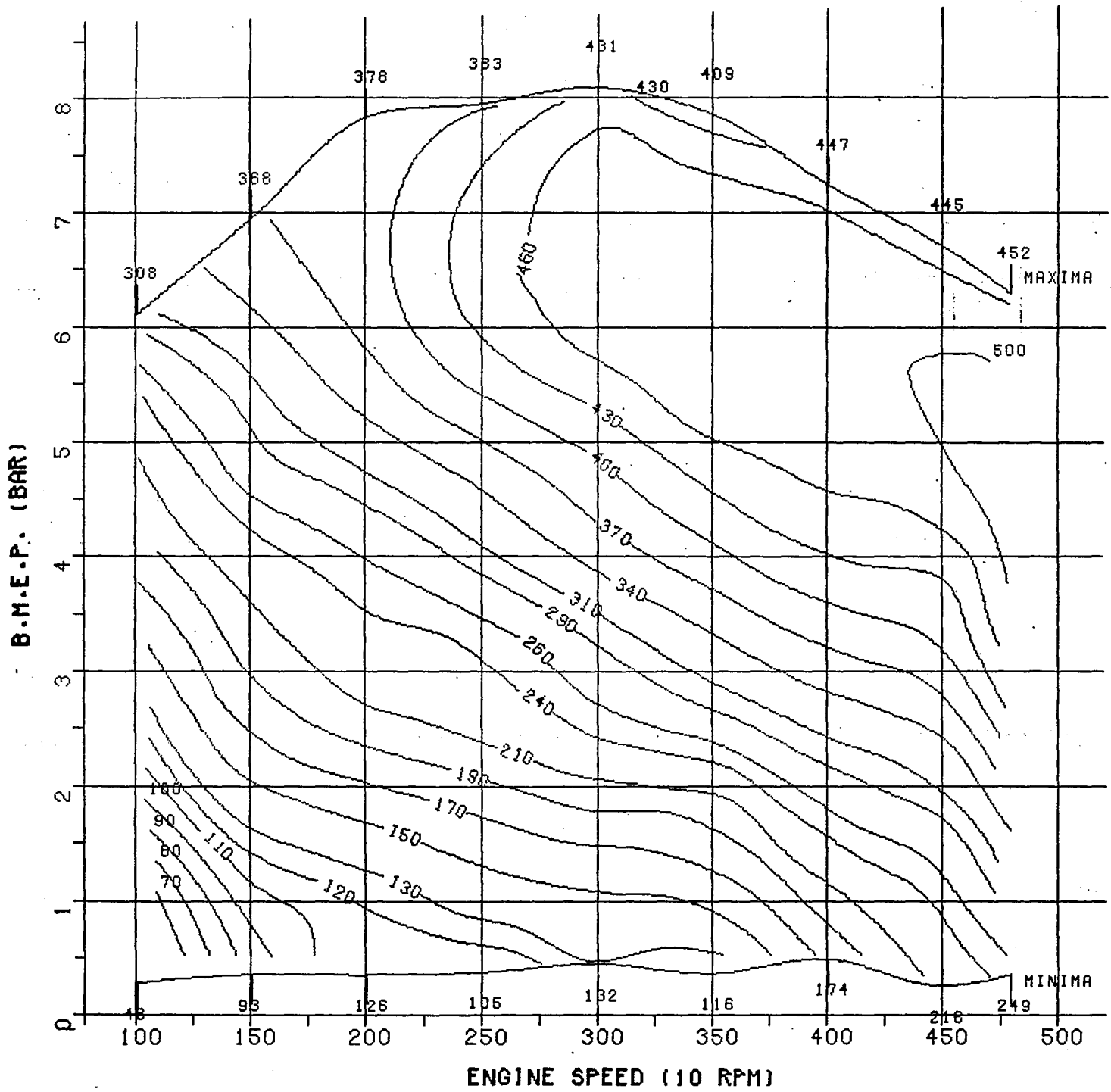

NO CONCENTRATION (PPM)
 6 CYLINDER 146 CID N.A. DIESEL ENGINE

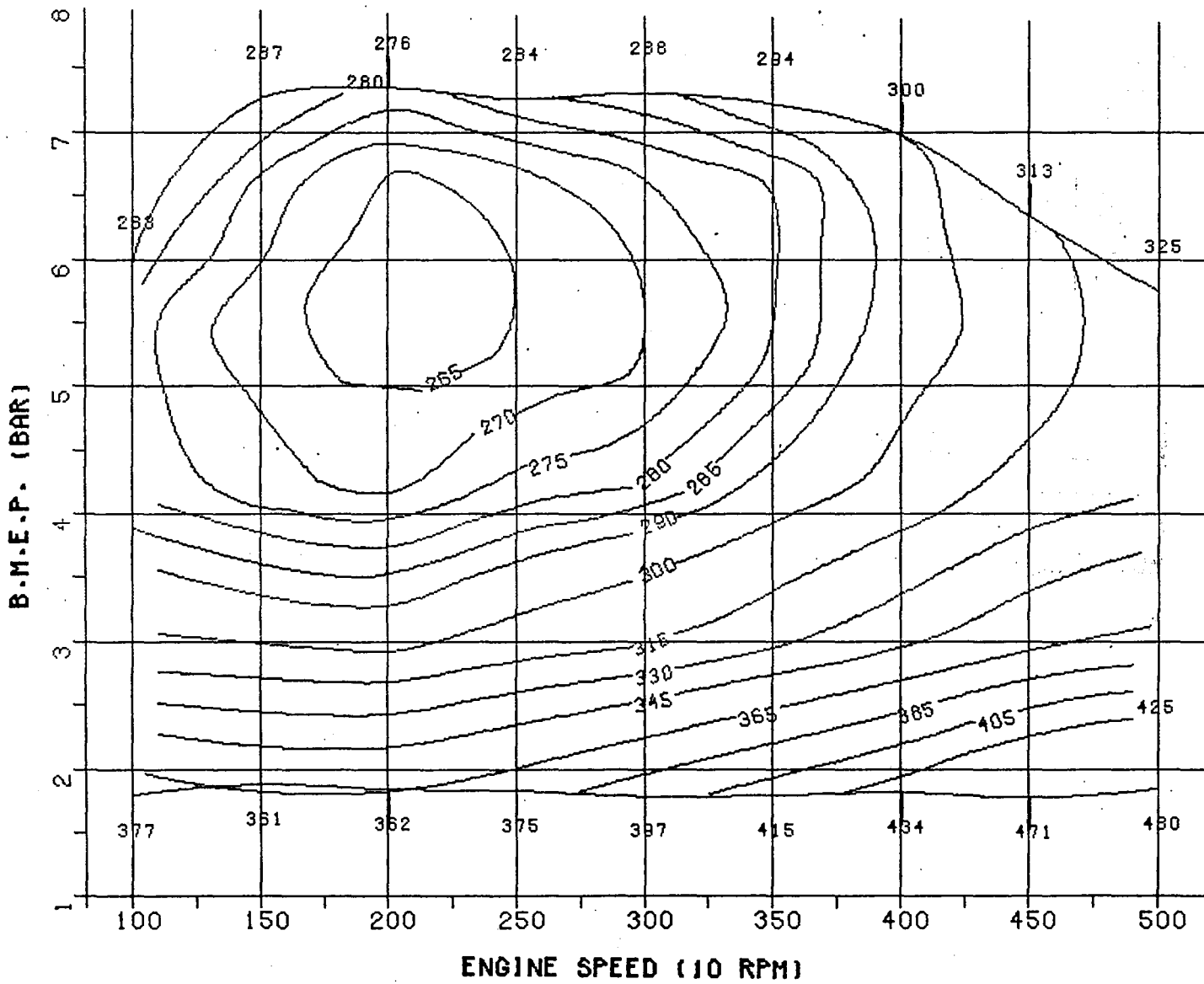

**SPECIFIC FUEL CONSUMPTION (G/KWH)
50 HP DIESEL, FUEL 15275**

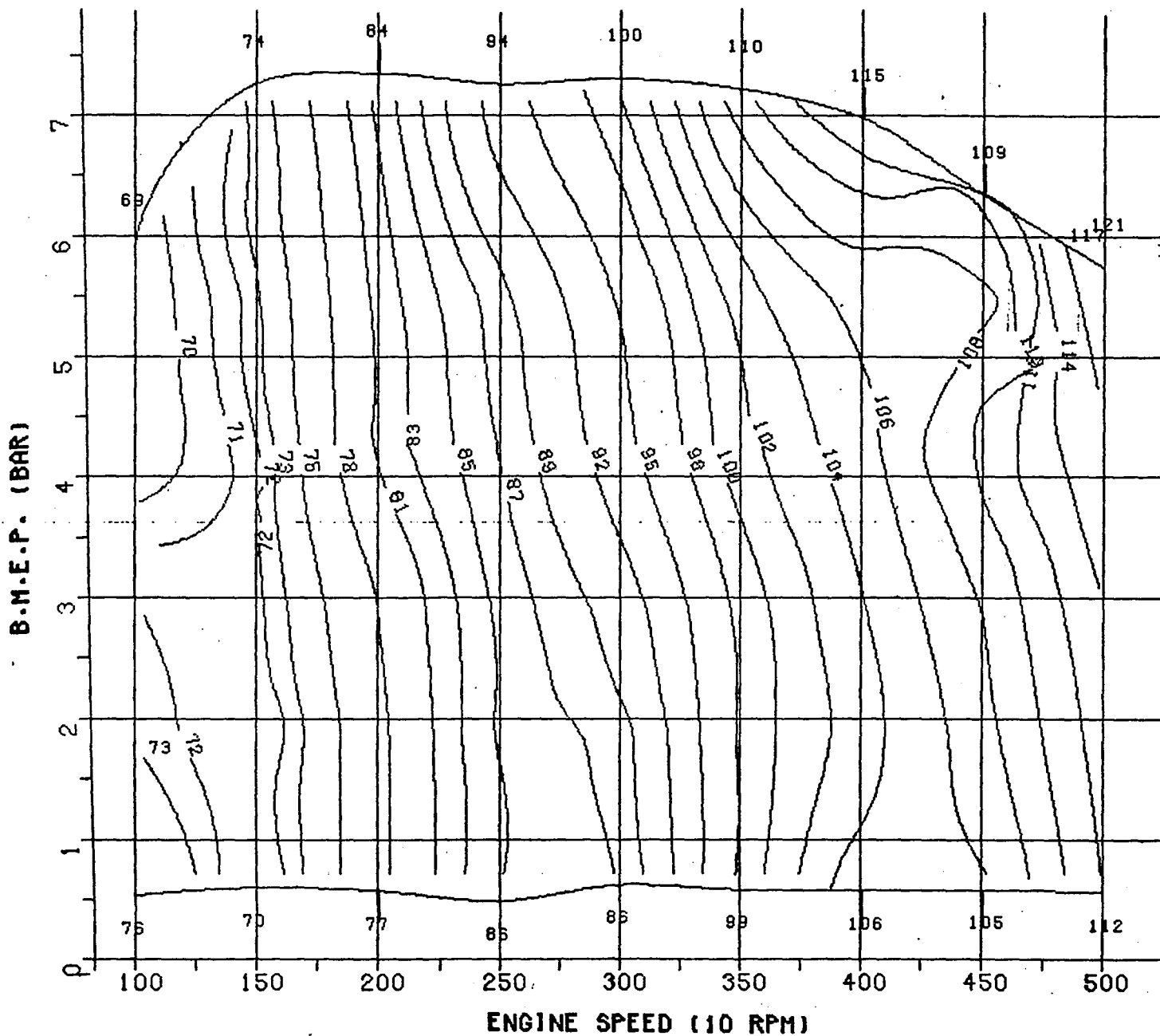

OIL TEMPERATURE (CELSIUS)
 50 HP DIESEL, FUEL 15275

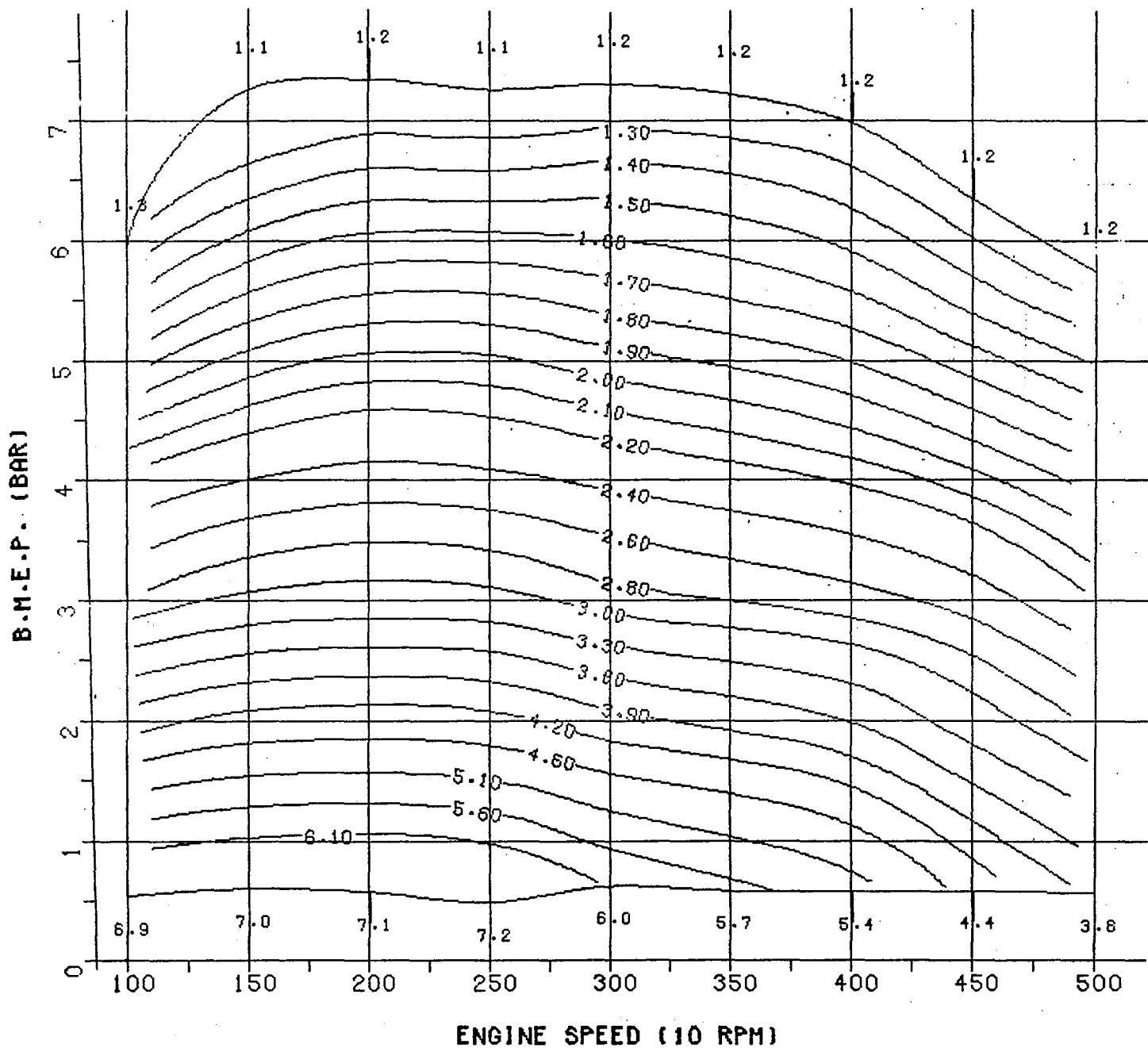

AIR TO FUEL RATIO
 50 HP DIESEL, FUEL 15275

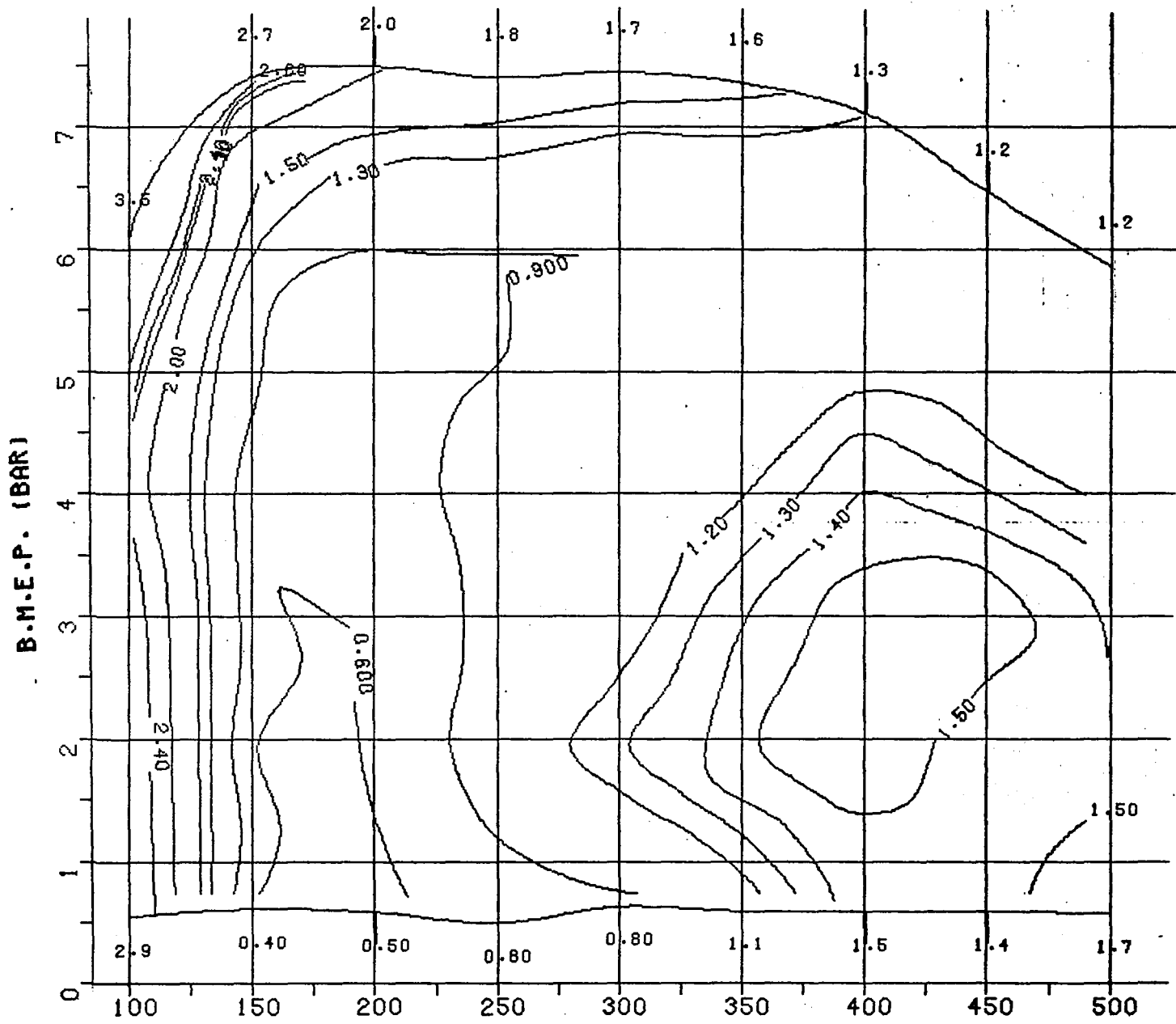

ENGINE SPEED (10 RPM)

SMOKE (BOSCH NUMBER)
50 HP DIESEL, FUEL 15275

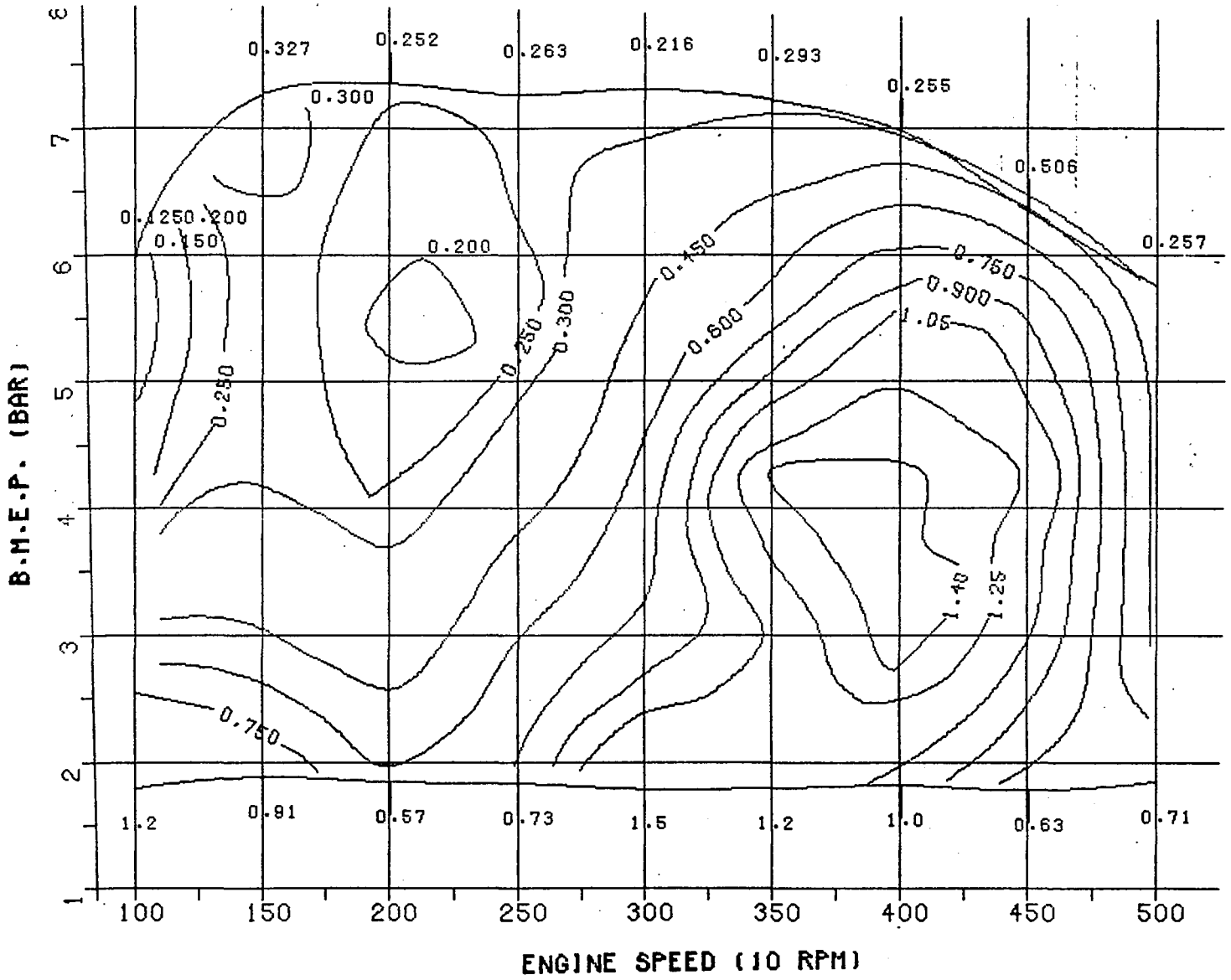

HC EMISSION (G/KWH)
 50 HP DIESEL, FUEL 15275

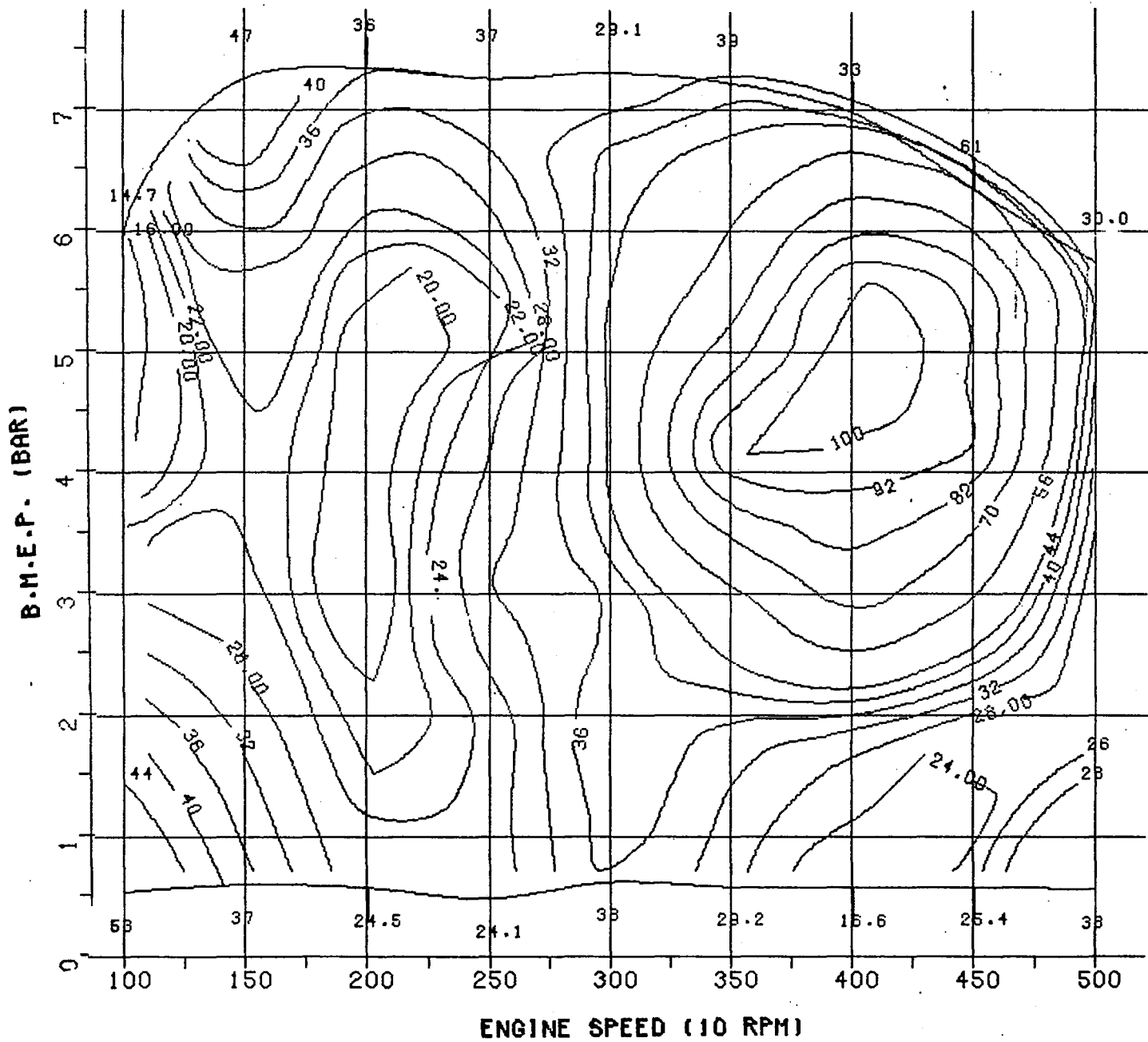

HC CONCENTRATION (PPM)
50 HP DIESEL, FUEL 15275

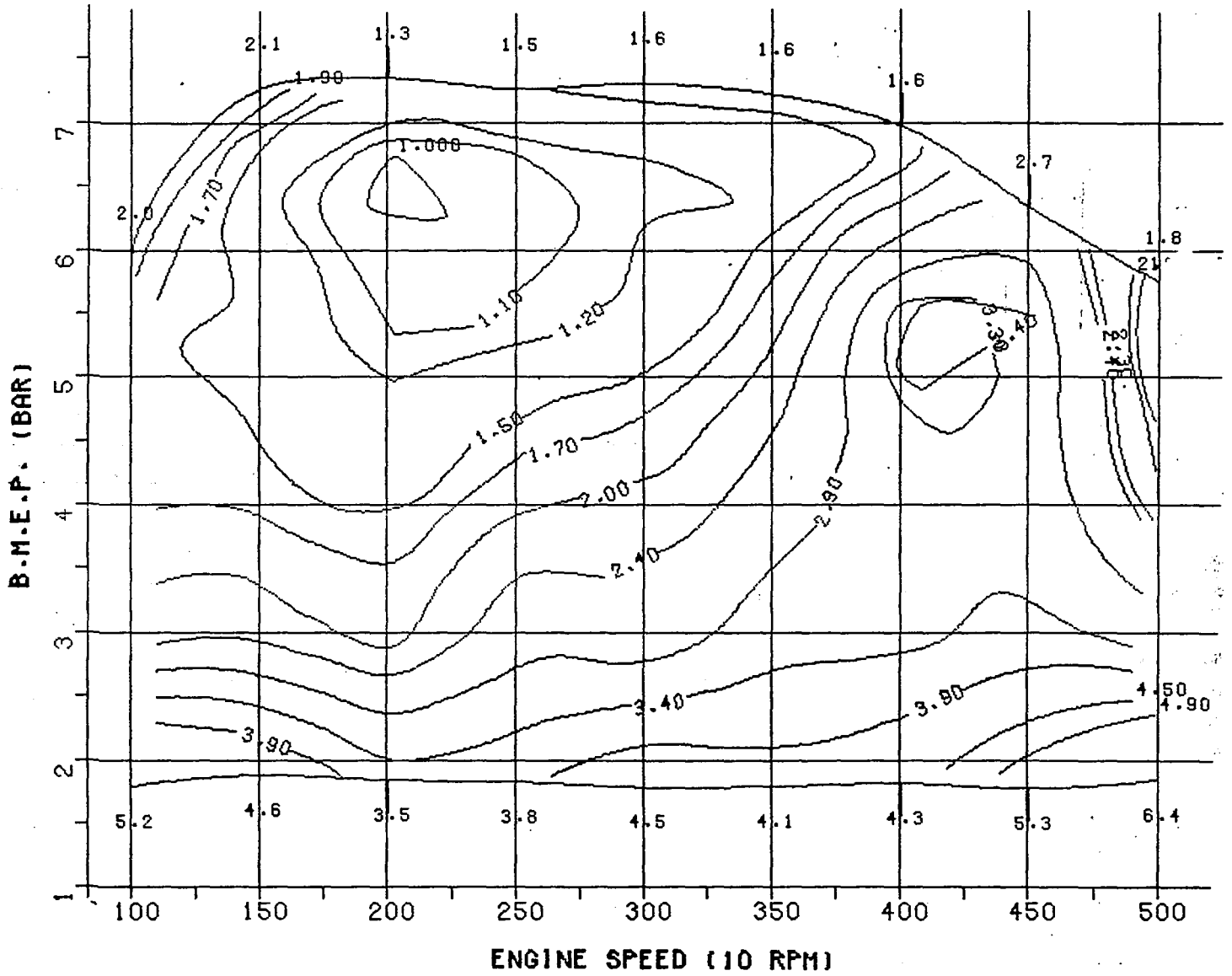

CO EMISSION (G/KWH)
50 HP DIESEL, FUEL 15275

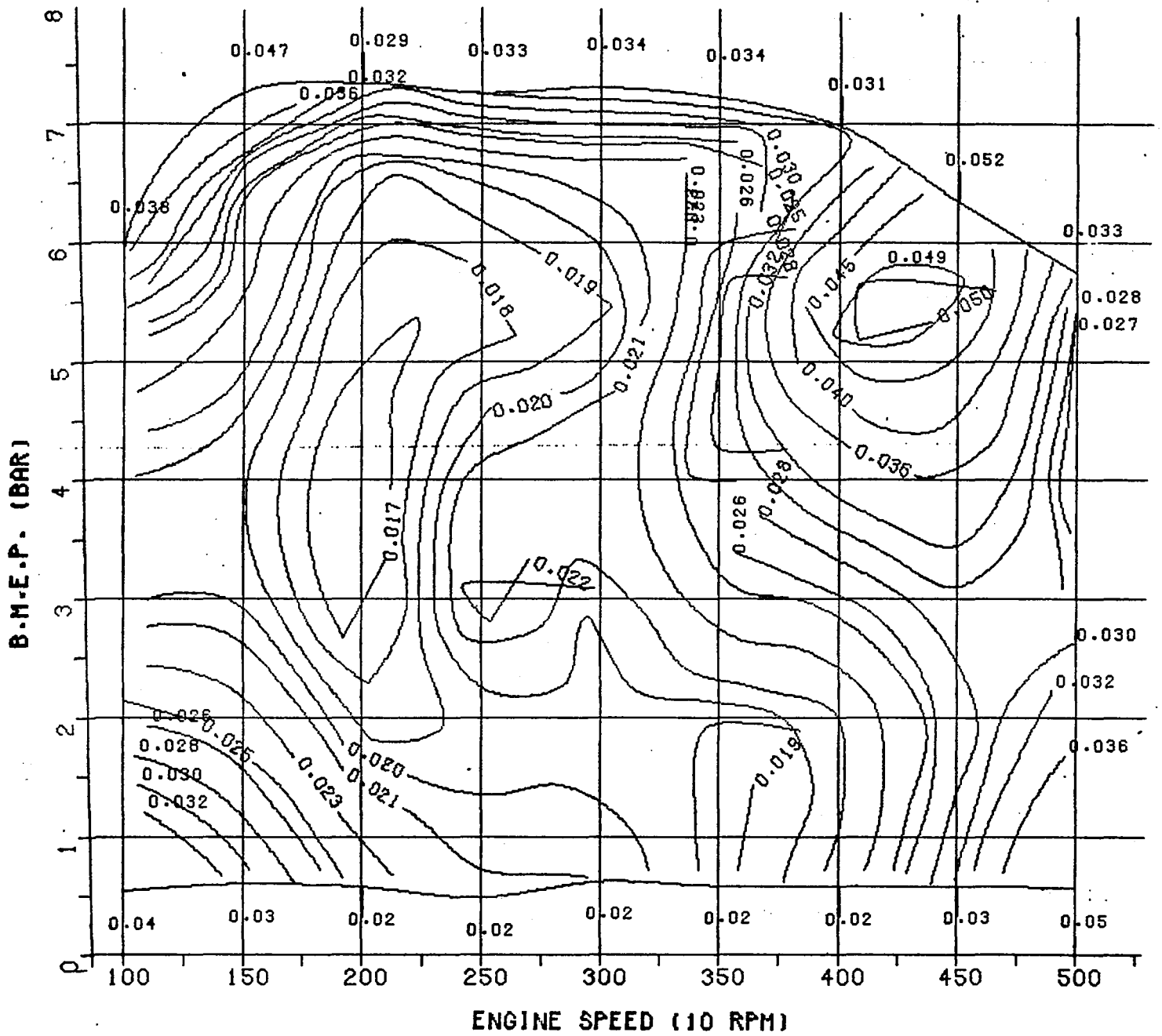

CO CONCENTRATION (%)
50 HP DIESEL, FUEL 15275

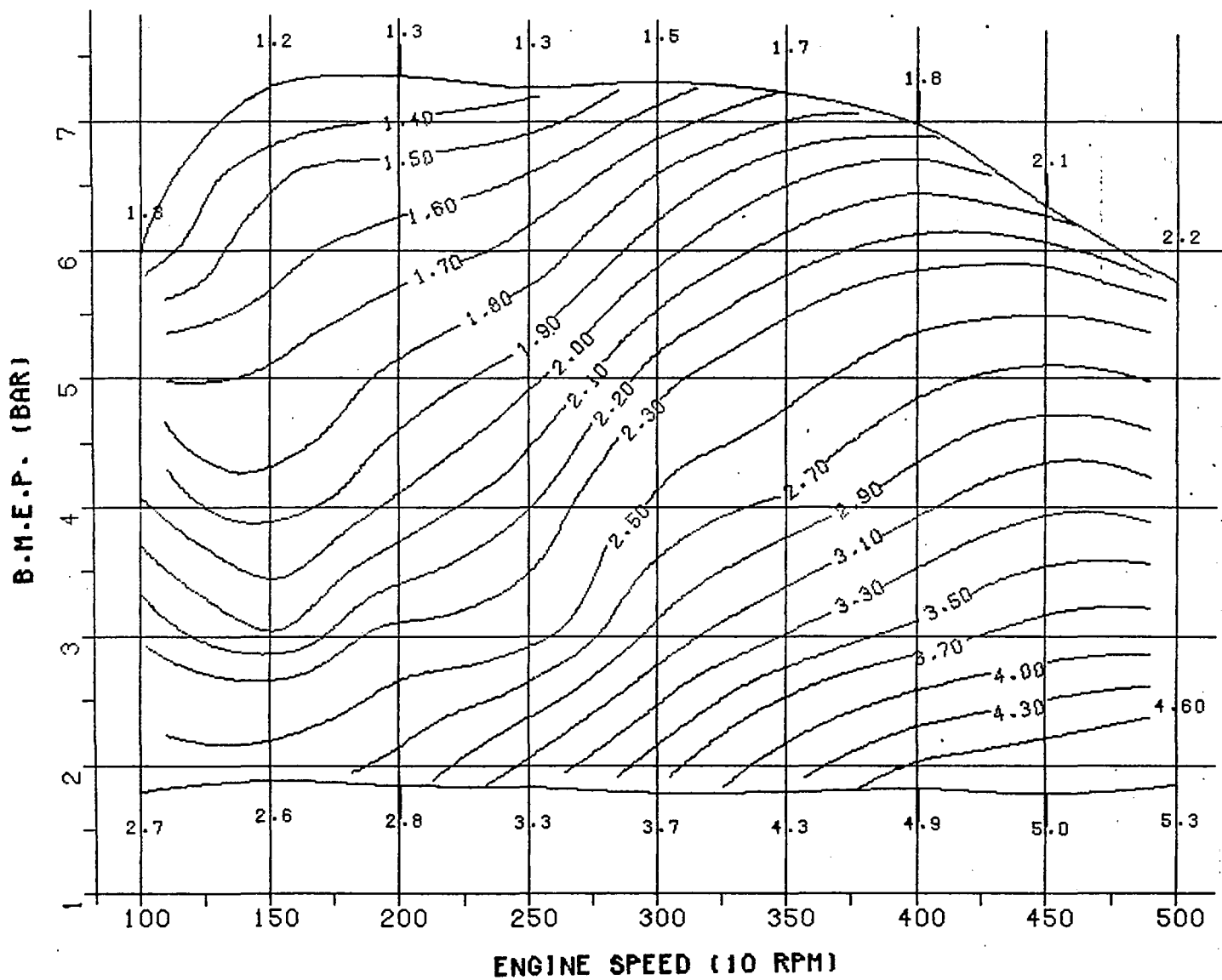

NO EMISSION (G/KWH)
 50 HP DIESEL, FUEL 15275

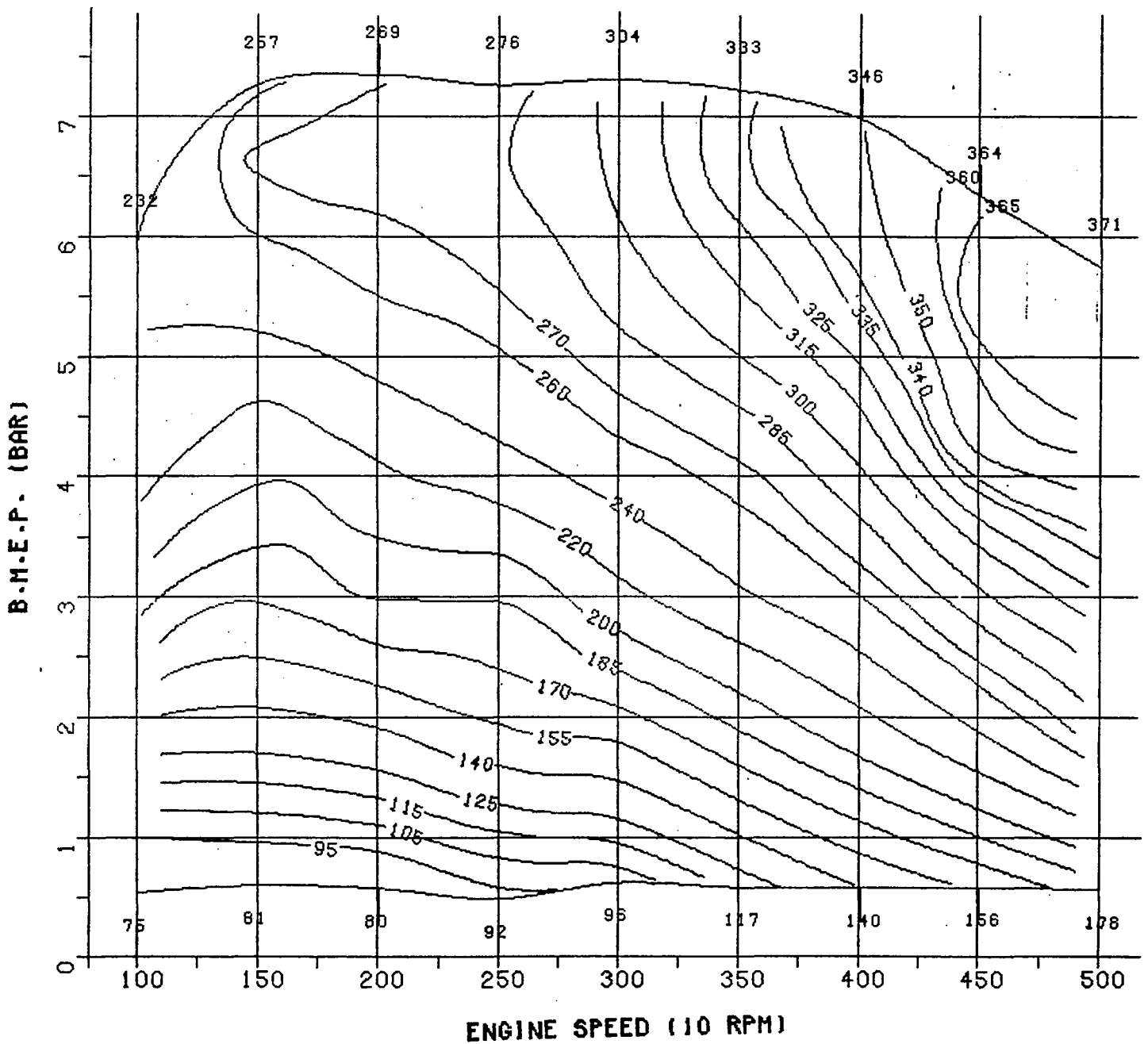

NO CONCENTRATION (PPM)
 50 HP DIESEL, FUEL 15275

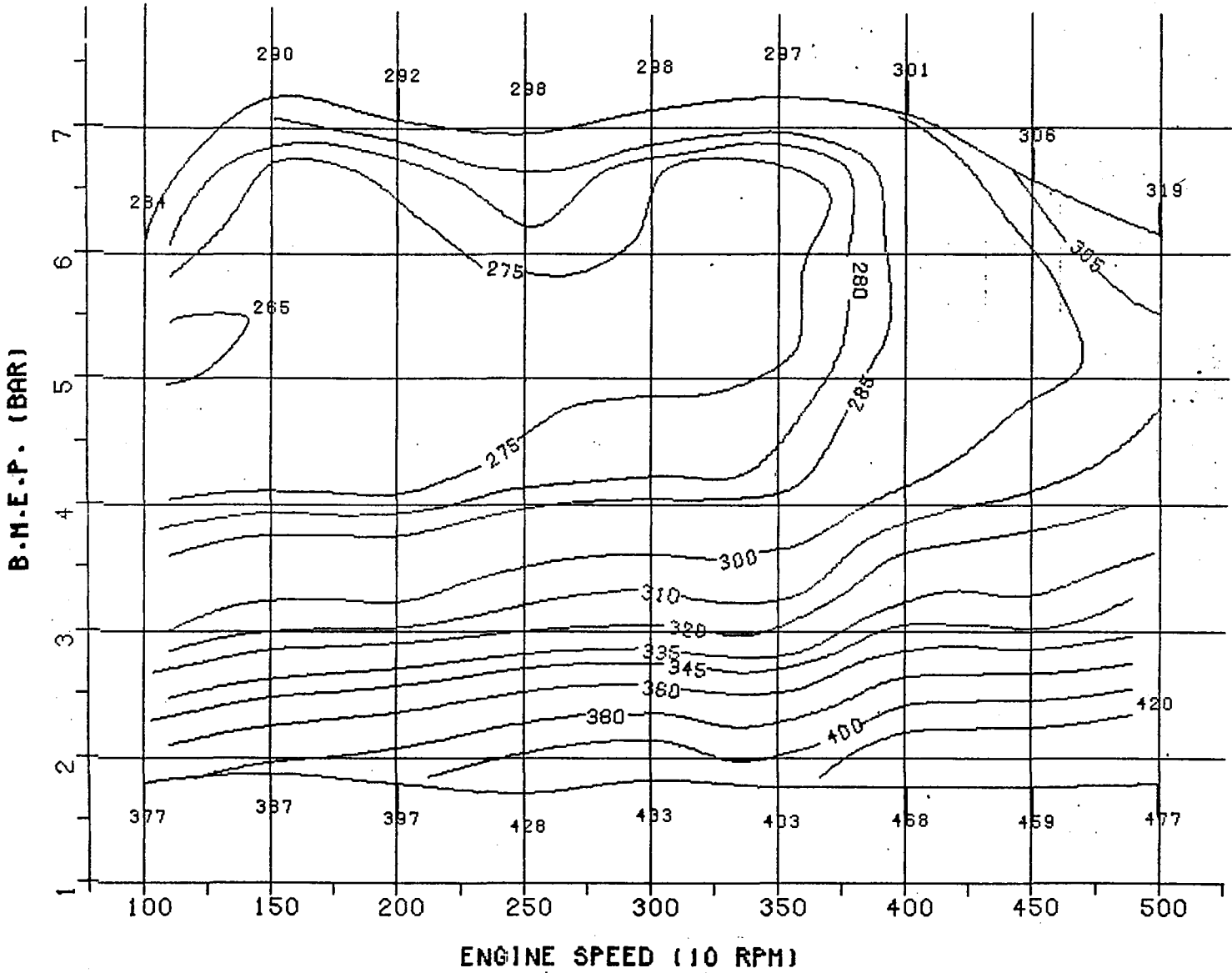

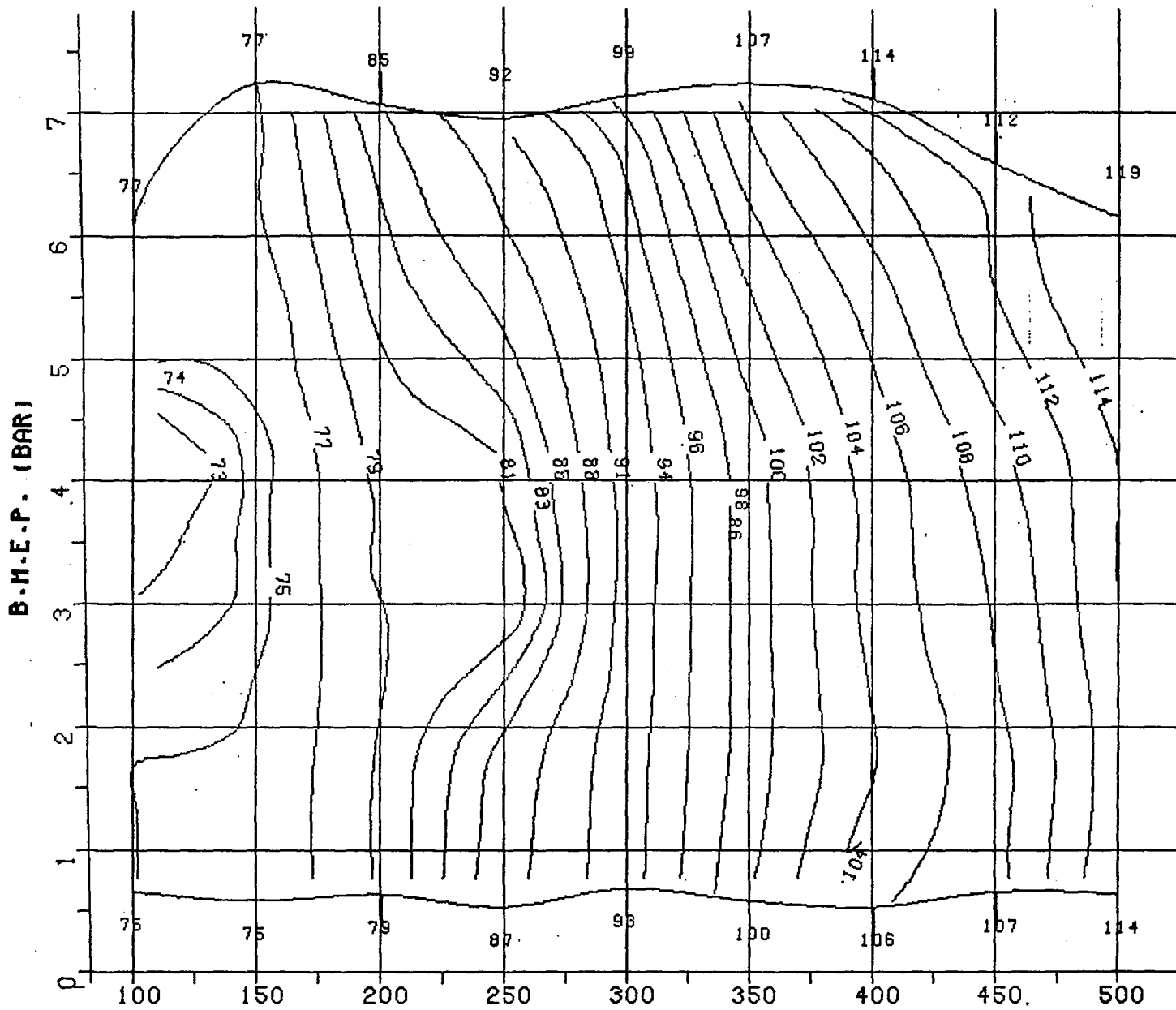

ENGINE SPEED (10 RPM)
 OIL TEMPERATURE (CELSIUS)
 50 HP DIESEL, FUEL 16086

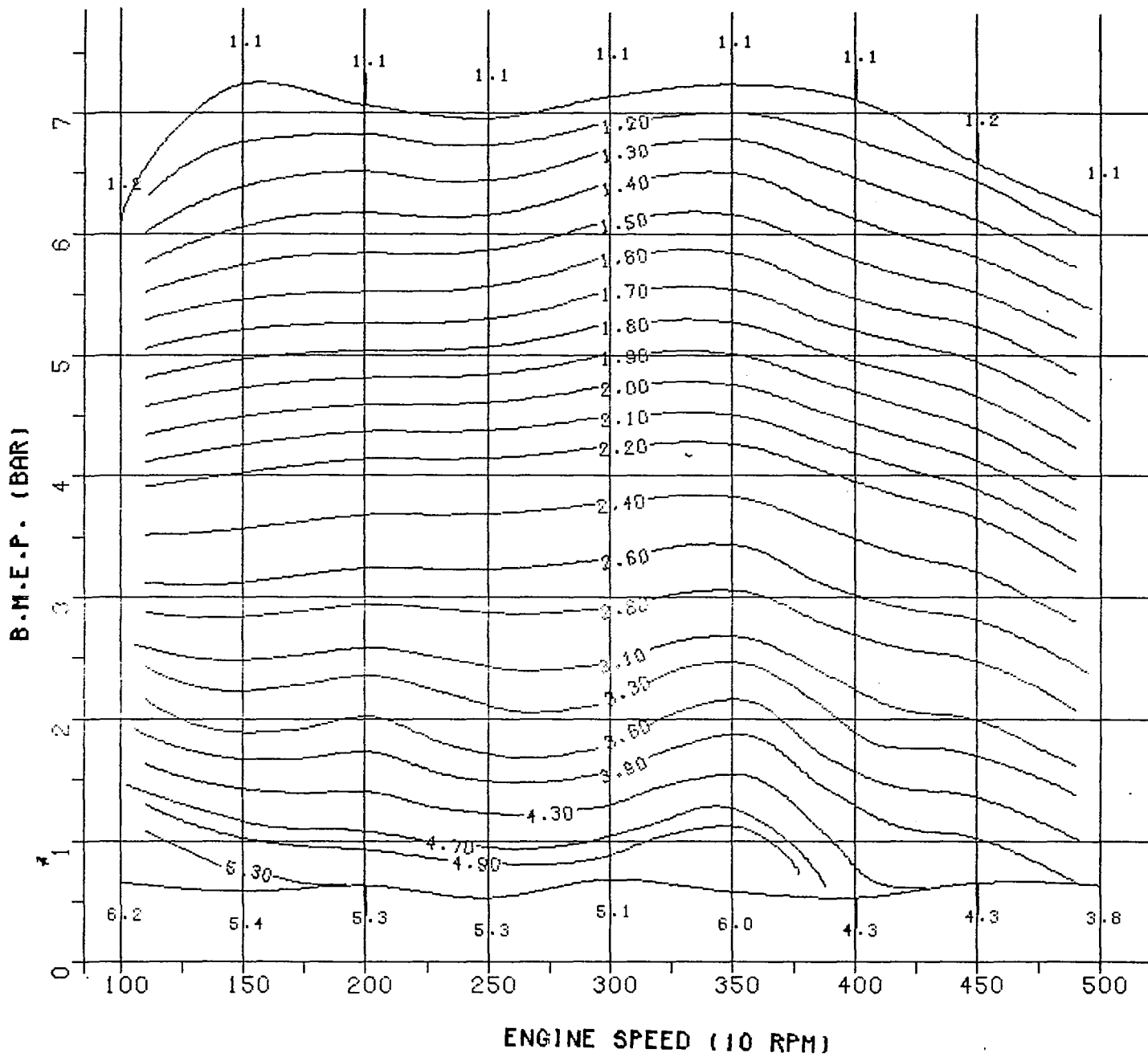

AIR TO FUEL RATIO
 50 HP DIESEL, FUEL 16086

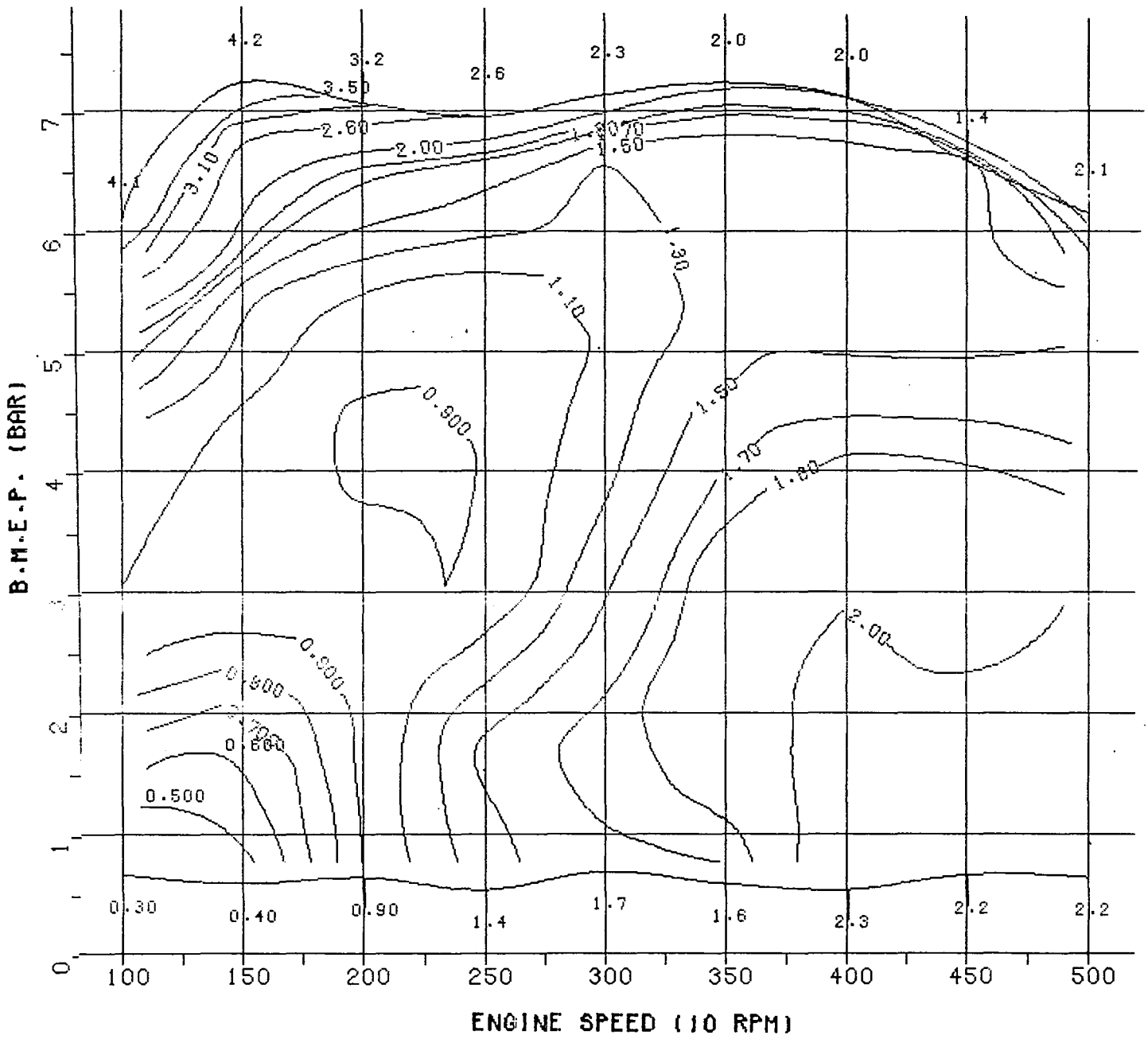

SMOKE (BOSCH NUMBER)
 50 HP DIESEL, FUEL 16086

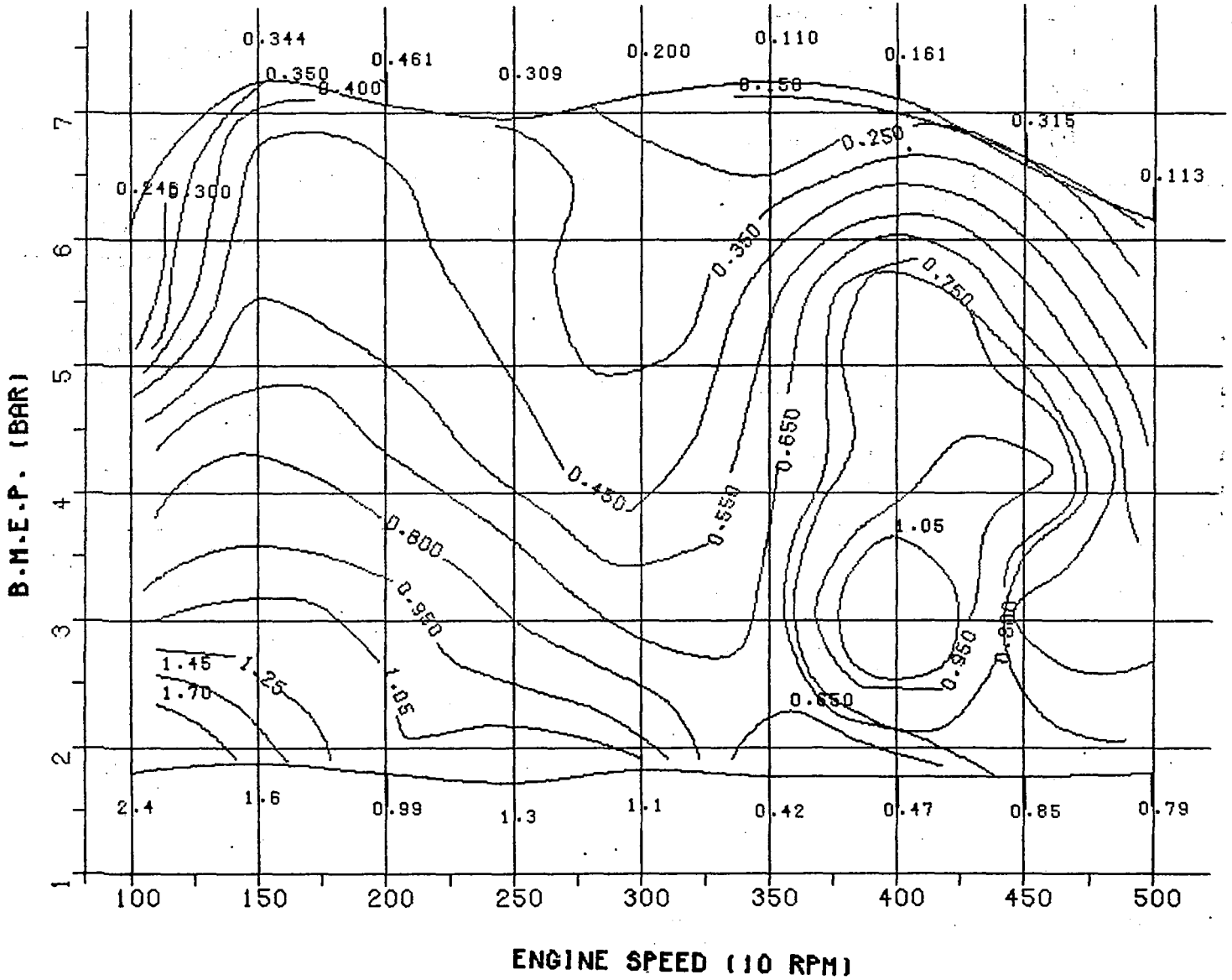

HC EMISSION (G/KWH)
 50 HP DIESEL, FUEL 16086

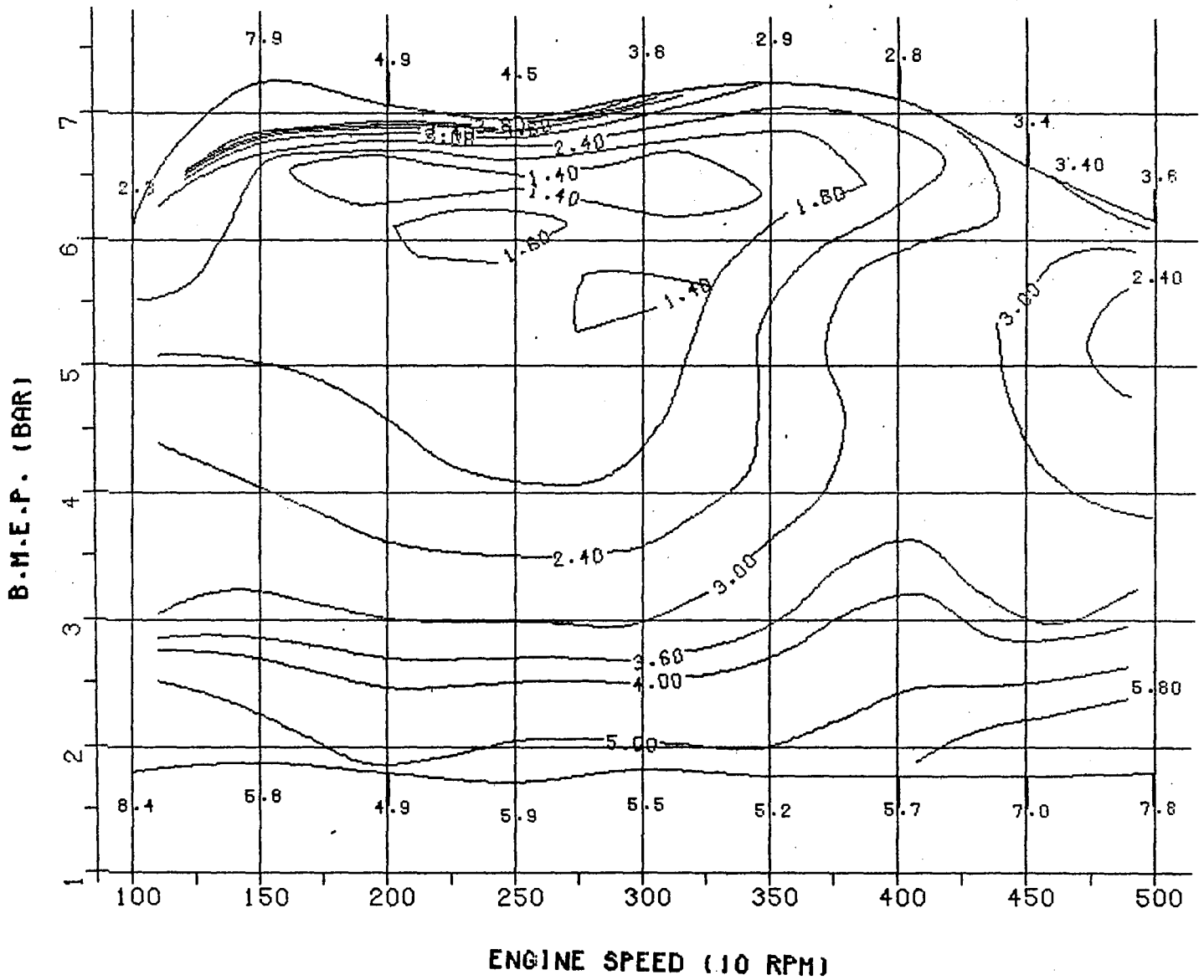

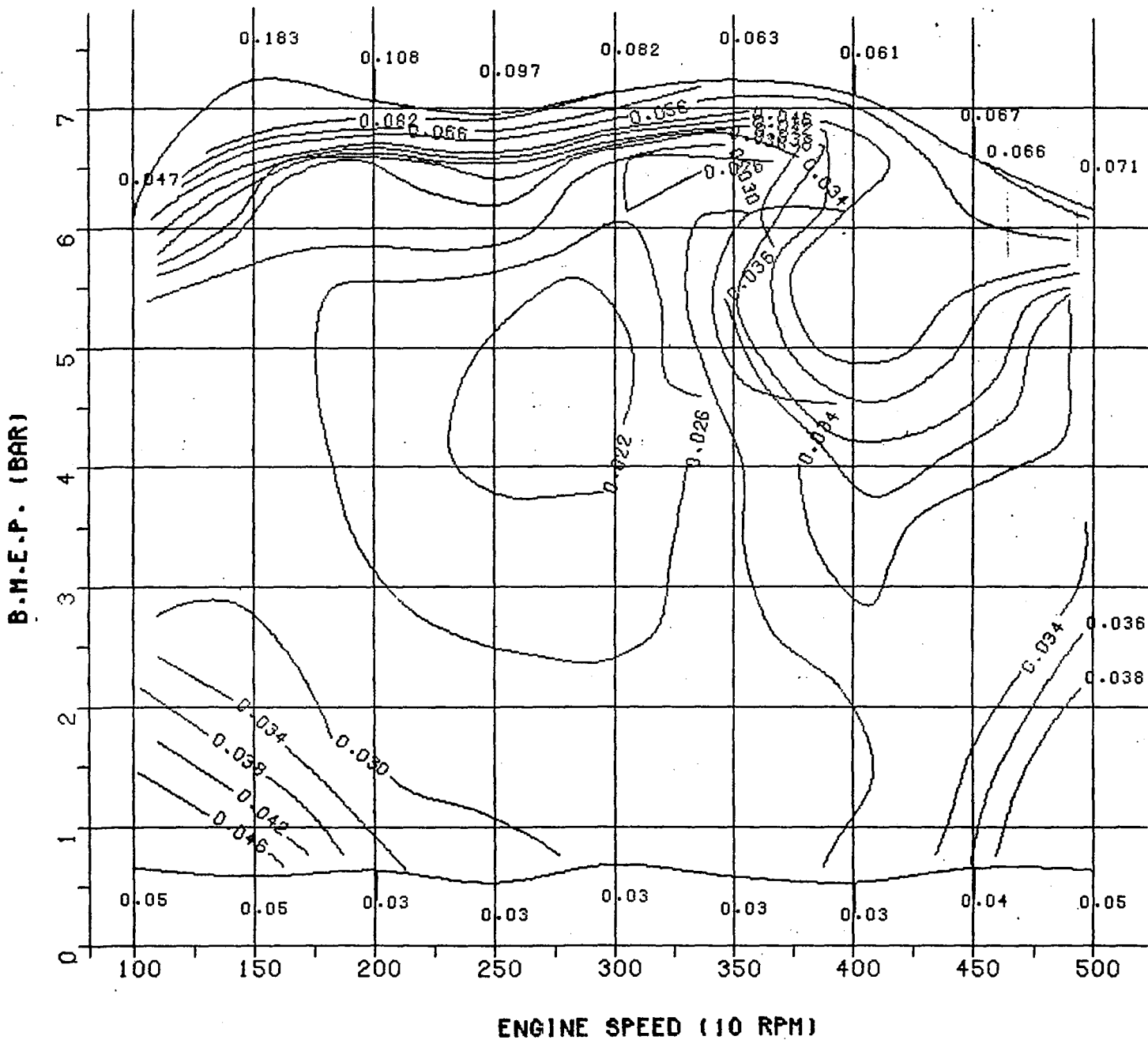

CO CONCENTRATION (%)
 50 HP DIESEL, FUEL 16086

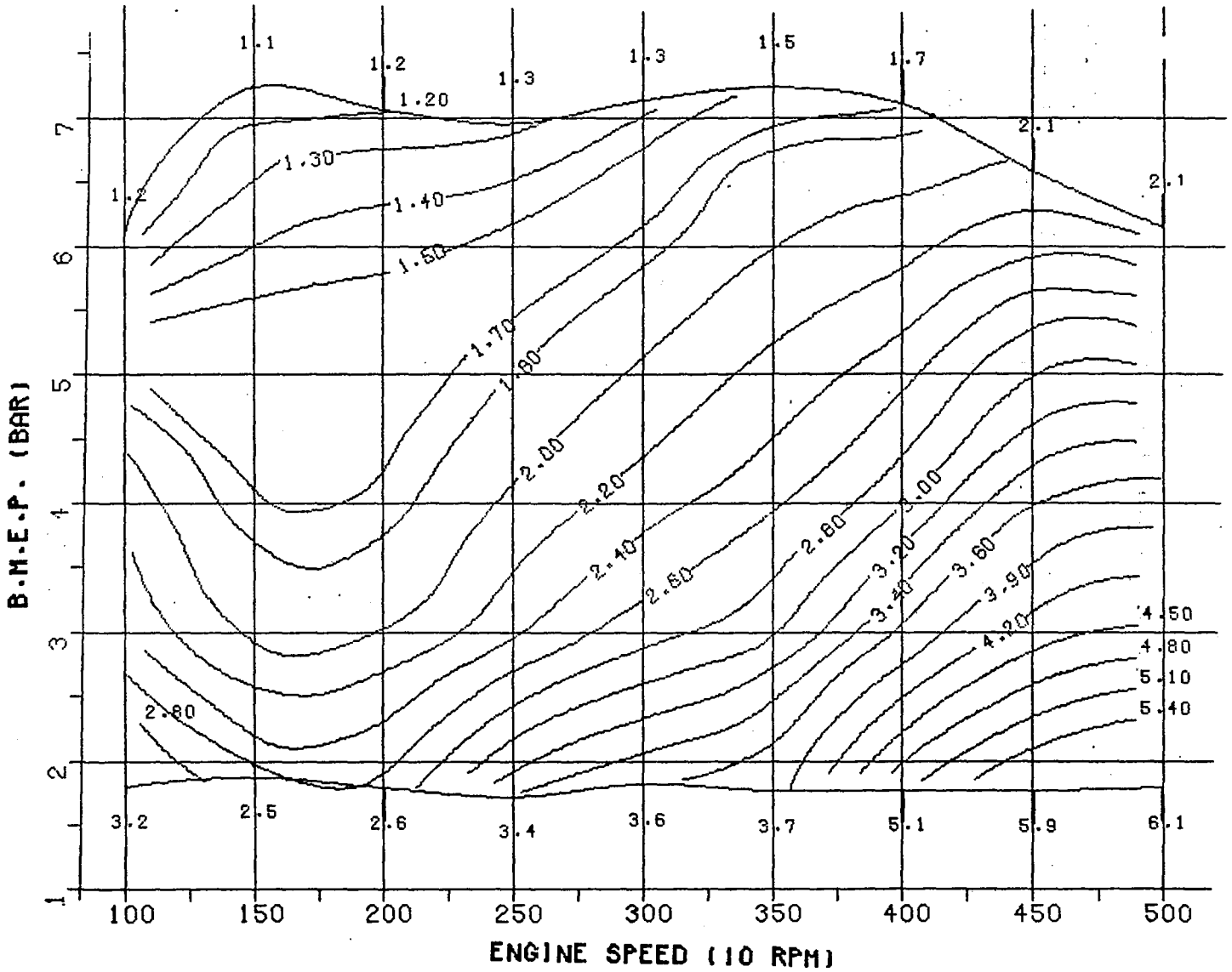

NO EMISSION (G/KWH)
50 HP DIESEL, FUEL 16086

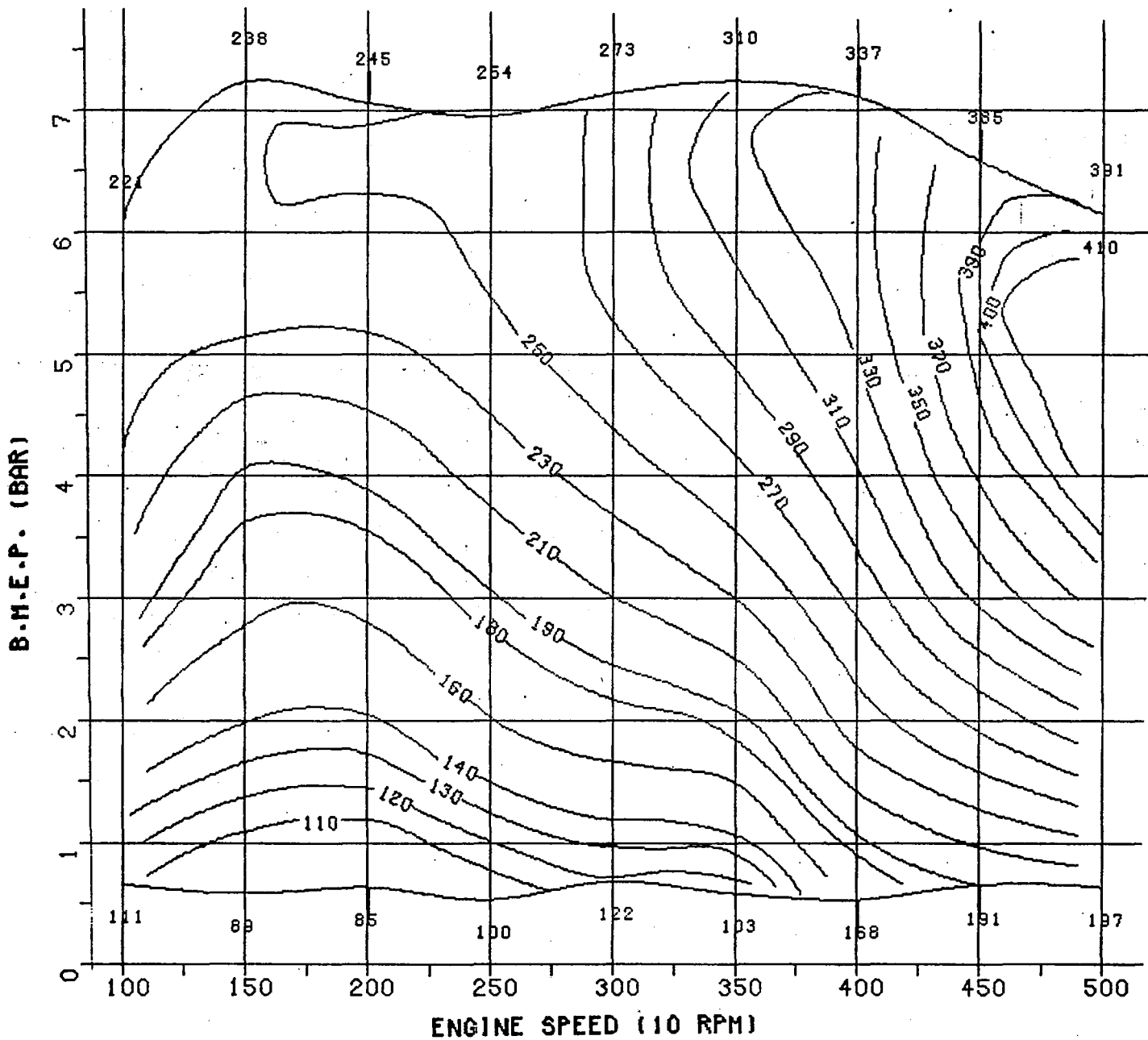

NO CONCENTRATION (PPM)
 50 HP DIESEL, FUEL 16086

- FULL LOAD
- † PROJECTED 8 CYLINDER N.A. DIESEL
 - ◇ PROJECTED 6 CYLINDER TC DIESEL
 - × 6 CYLINDER 146 CID N.A. DIESEL
 - + 6 CYLINDER 130 CID N.A. DIESEL
 - ▲ 70 HP TC RESEARCH DIESEL
 - 60 HP N.A. PRODUCTION DIESEL

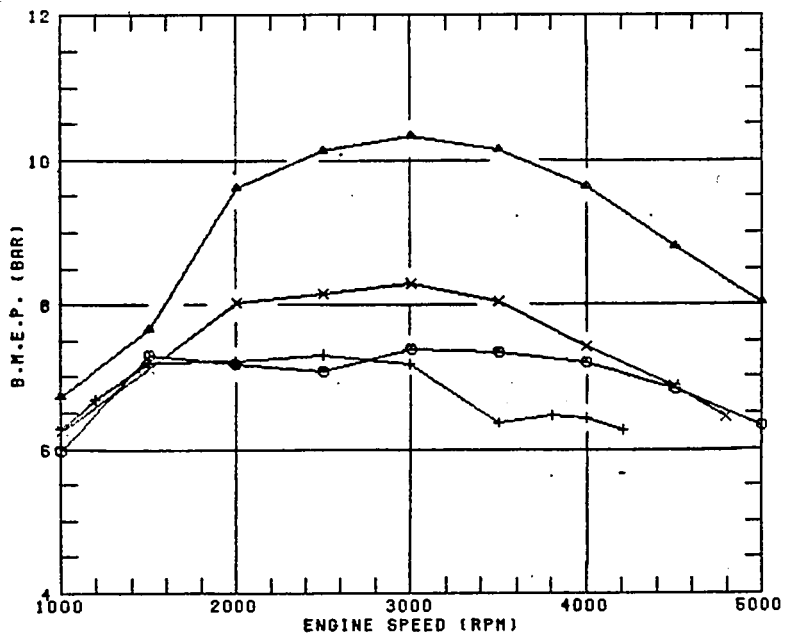
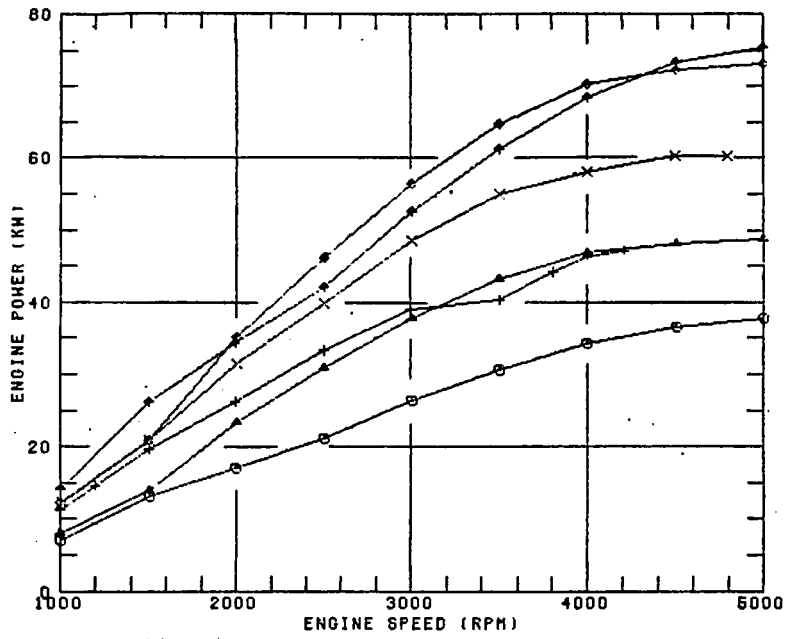

FULL LOAD
 × 6 CYLINDER 146 CID N.A. DIESEL
 + 5 CYLINDER 130 CID N.A. DIESEL
 ▲ 70 HP TC RESEARCH DIESEL
 ○ 50 HP N.A. PRODUCTION DIESEL

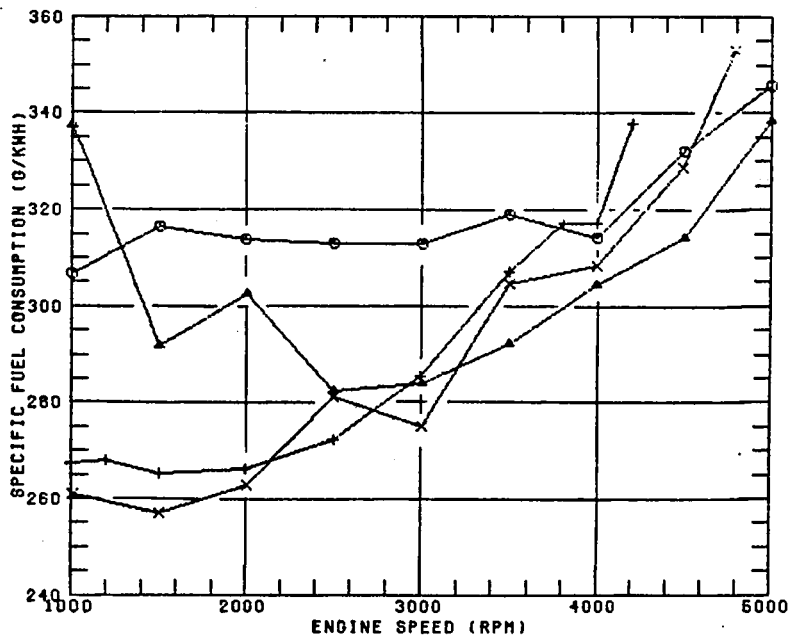
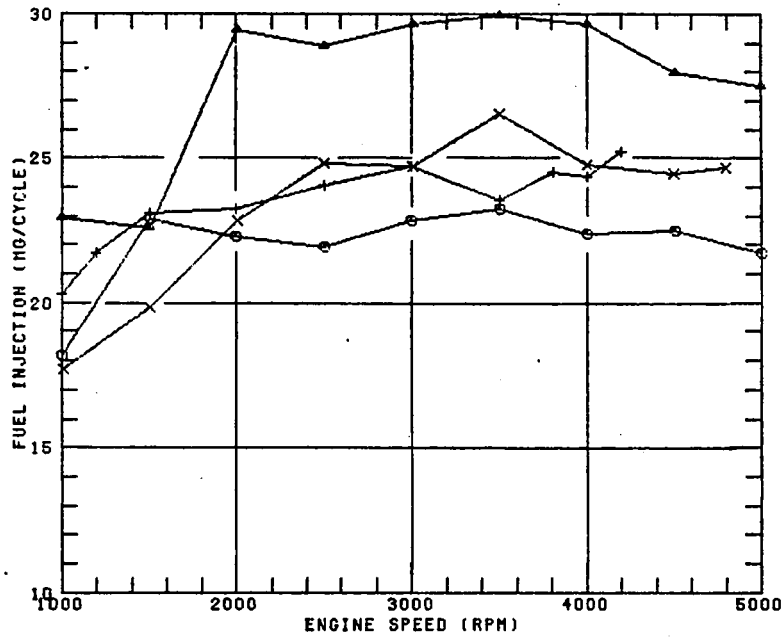

FULL LOAD
 X 6 CYLINDER 146 CID N.A. DIESEL
 + 6 CYLINDER 130 CID N.A. DIESEL
 ▲ 70 HP TC RESEARCH DIESEL
 ○ 60 HP N.A. PRODUCTION DIESEL

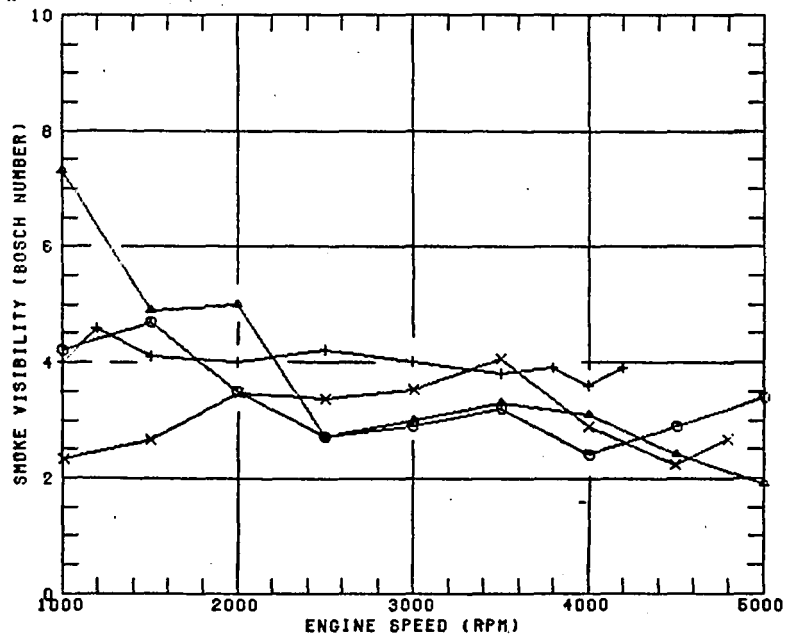
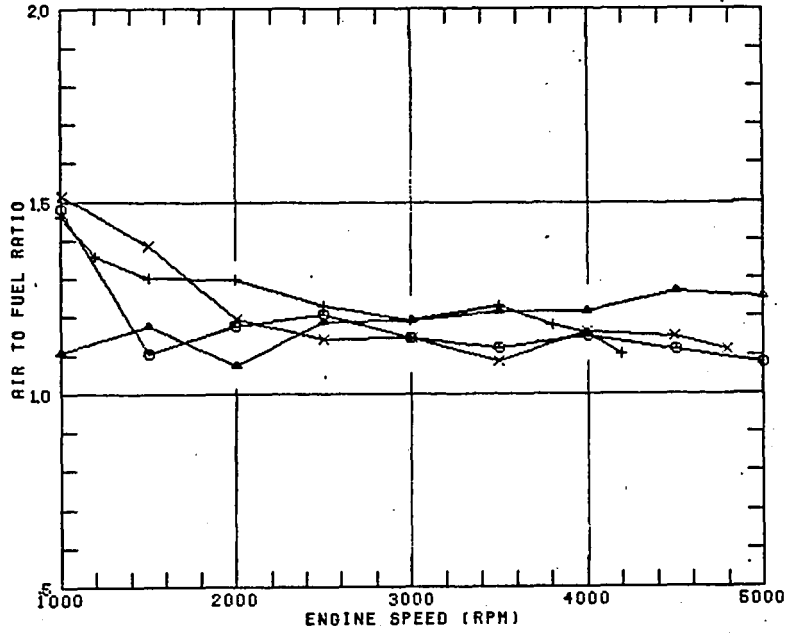

FULL LOAD
 X 6 CYLINDER 146 CID N.A. DIESEL
 + 5 CYLINDER 130 CID N.A. DIESEL
 ▲ 70 HP TC RESEARCH DIESEL
 ● 60 HP N.A. PRODUCTION DIESEL

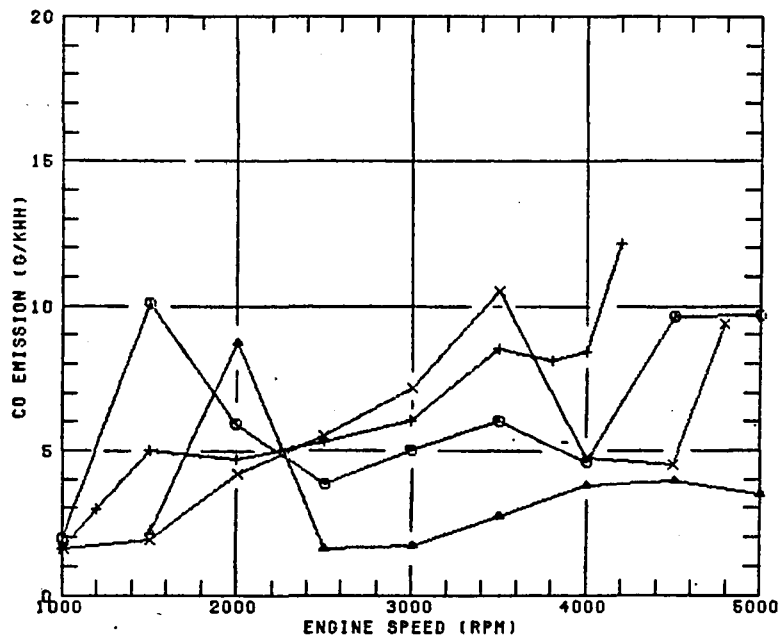
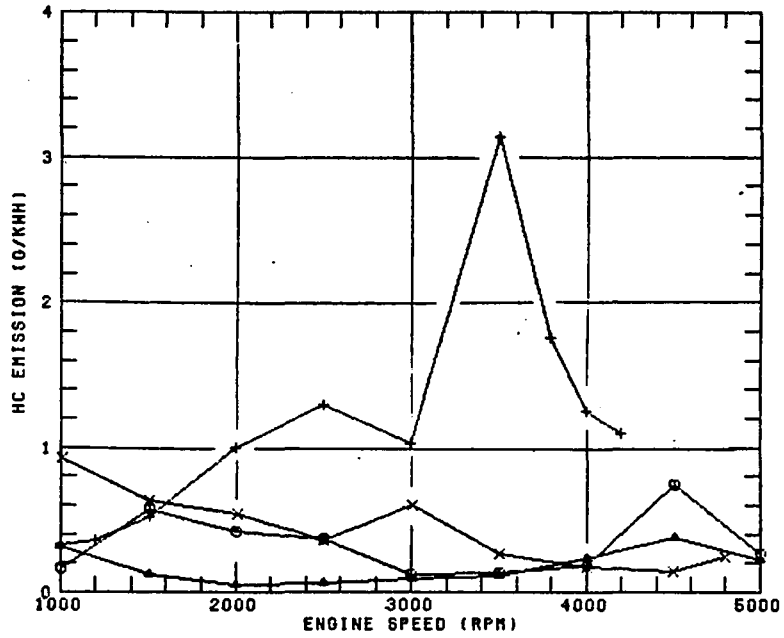

FULL LOAD

- x 6 CYLINDER 146 CID N.A. DIESEL
- + 5 CYLINDER 130 CID N.A. DIESEL
- ▲ 70 HP TC RESEARCH DIESEL
- ⊙ 50 HP N.A. PRODUCTION DIESEL

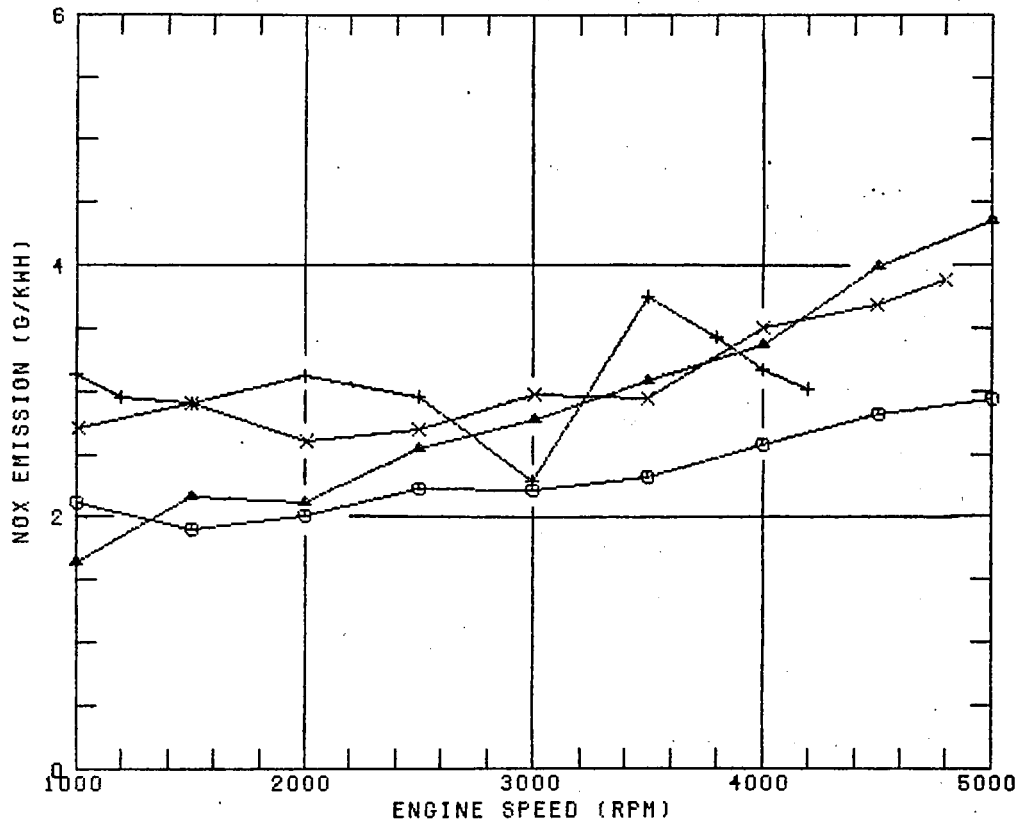

FULL LOAD INJECTION TIMING
 150 HP N.A. DIESEL 70 HP TC DIESEL
 + 2 DEG. BEFORE TDC + 2 DEG. BEFORE TDC
 ▲ 0 DEGREE ◆ 0 DEGREE
 ○ 3 DEG. AFTER TDC × 3 DEG. AFTER TDC

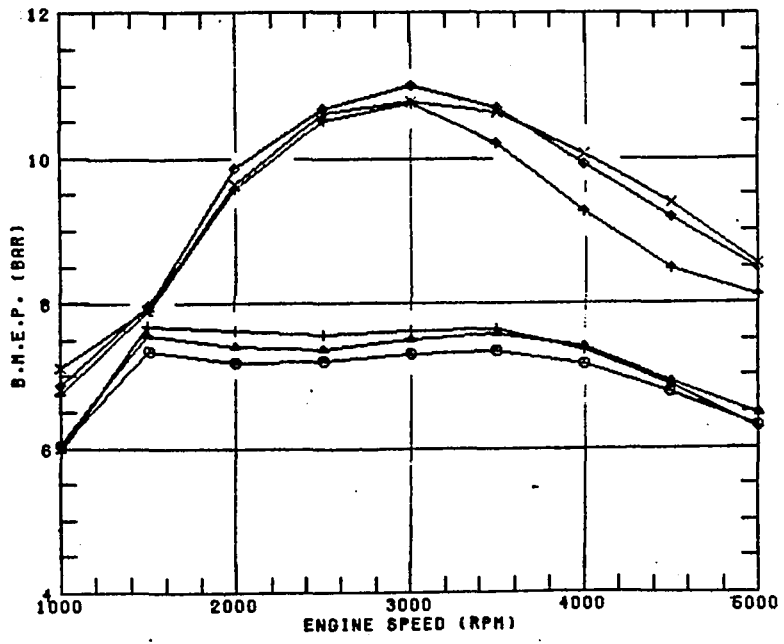
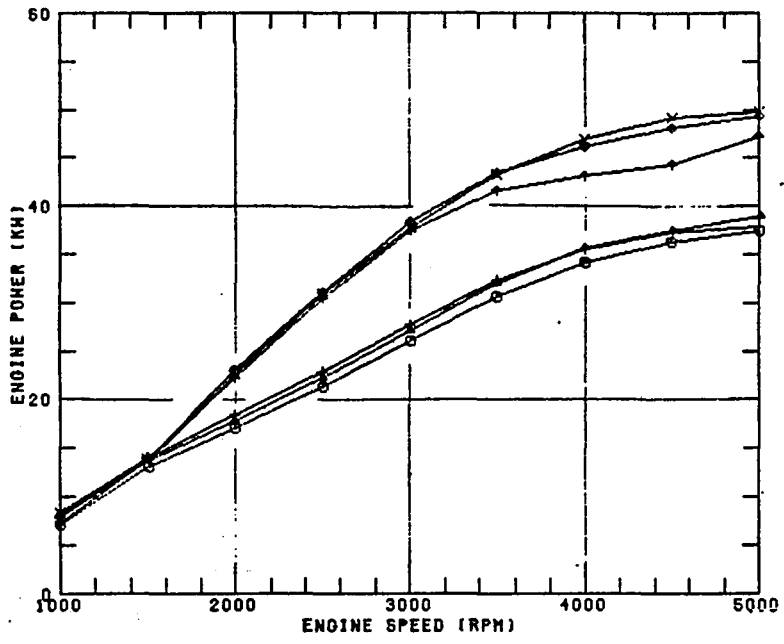

FULL LOAD INJECTION TIMING
 50 HP N.A. DIESEL 70 HP TC DIESEL
 + 2 DEG. BEFORE TDC + 2 DEG. BEFORE TDC
 ▲ 0 DEGREE ◆ 0 DEGREE
 ○ 3 DEG. AFTER TDC × 3 DEG. AFTER TDC

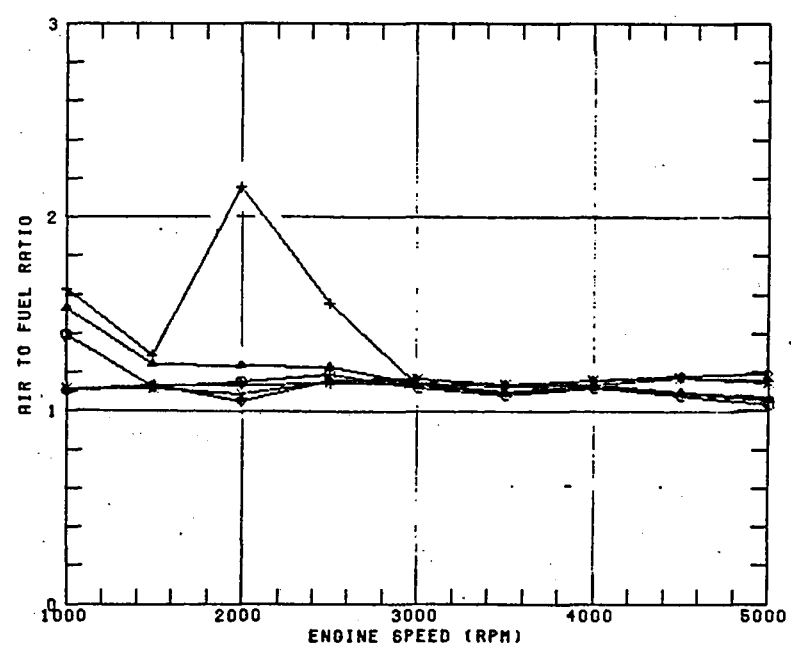
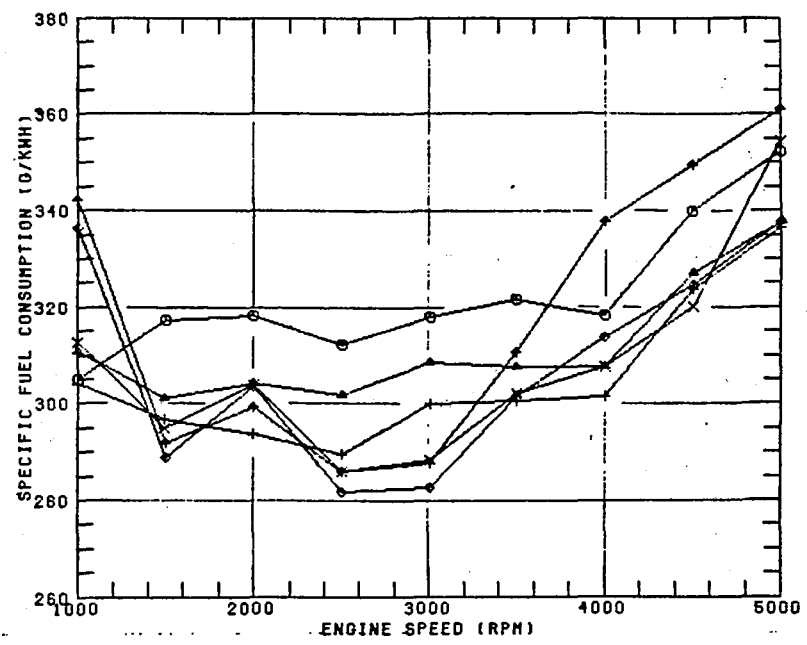

FULL LOAD INJECTION TIMING
 50 HP N.A. DIESEL 70 HP TC DIESEL
 + 2 DEG. BEFORE TDC + 2 DEG. BEFORE TDC
 ▲ 0 DEGREE ◆ 0 DEGREE
 ○ 3 DEG. AFTER TDC × 3 DEG. AFTER TDC

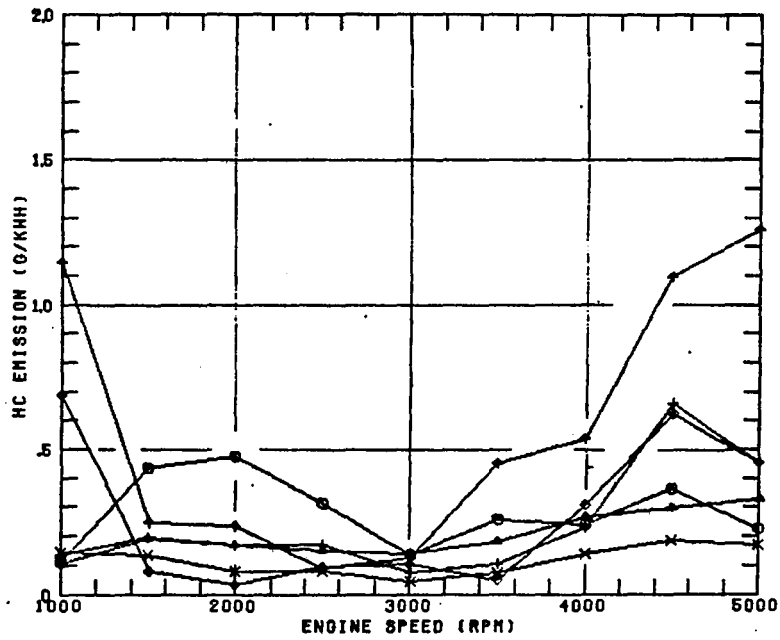
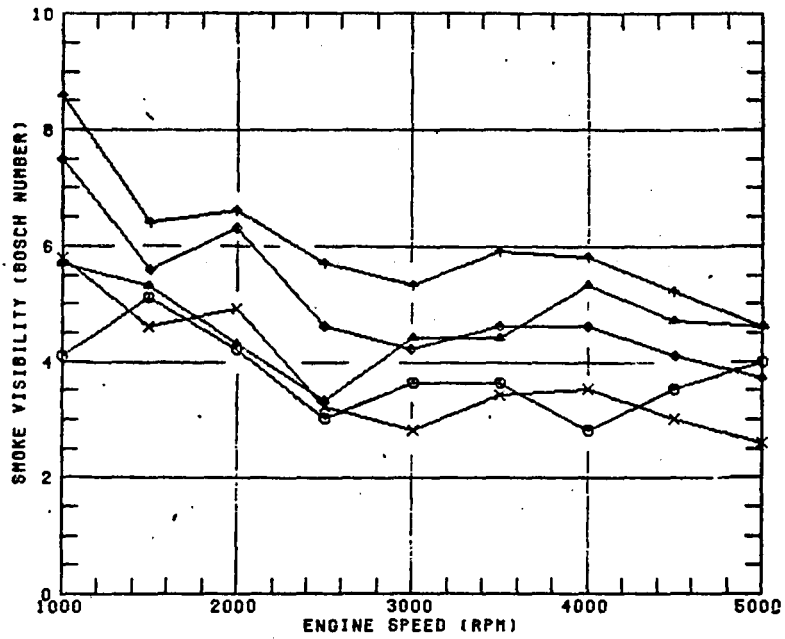

FULL LOAD INJECTION TIMING
 50 HP N.A. DIESEL 70 HP TC DIESEL
 + 2 DEG. BEFORE TDC + 2 DEG. BEFORE TDC
 ▲ 0 DEGREE ◆ 0 DEGREE
 ○ 3 DEG. AFTER TDC × 3 DEG. AFTER TDC

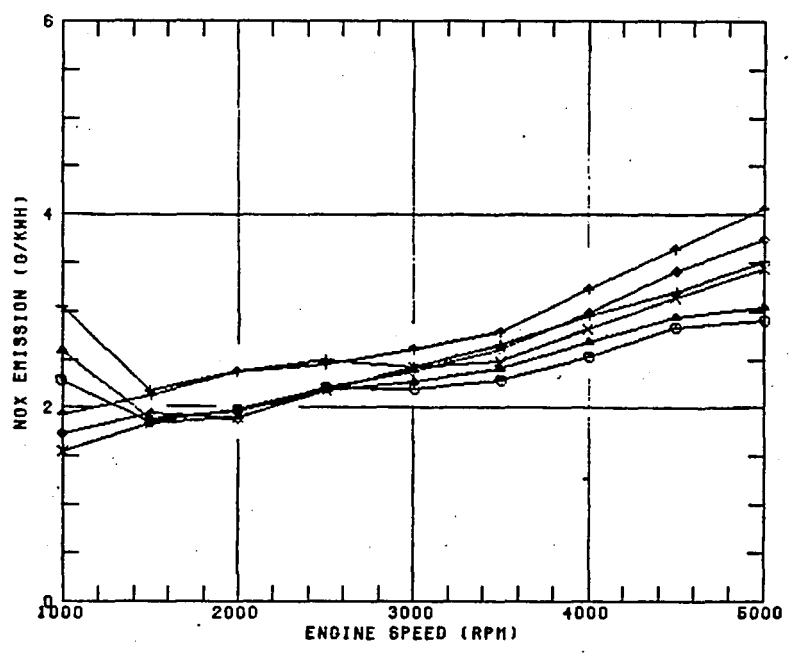
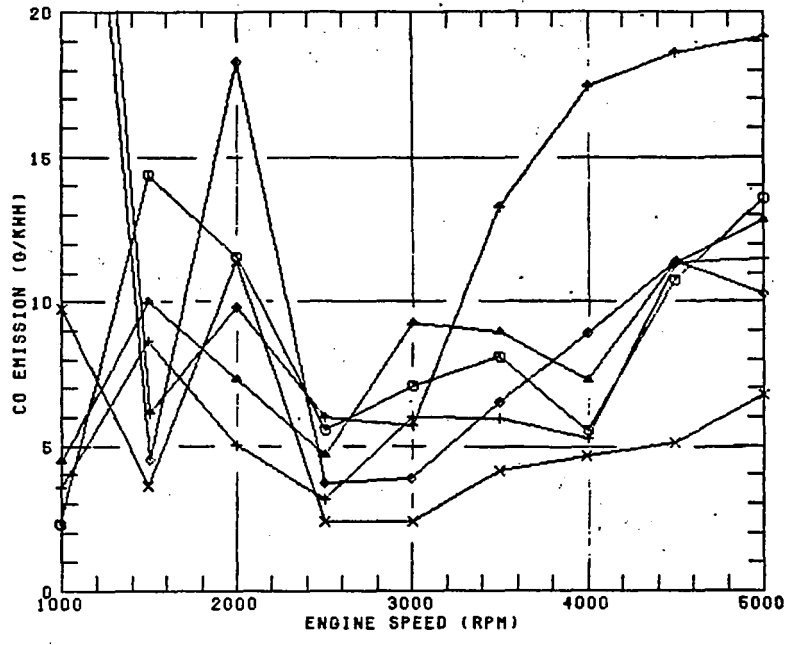

FULL LOAD: FUEL NUMBER/FUEL DENSITY

- | | |
|---------------|---------------|
| ○ 323/0.841 | ◇ 16140/0.834 |
| ▲ 15275/0.840 | ↑ 16160/0.843 |
| + 16086/0.825 | × 16164/0.869 |
| × 16120/0.817 | |

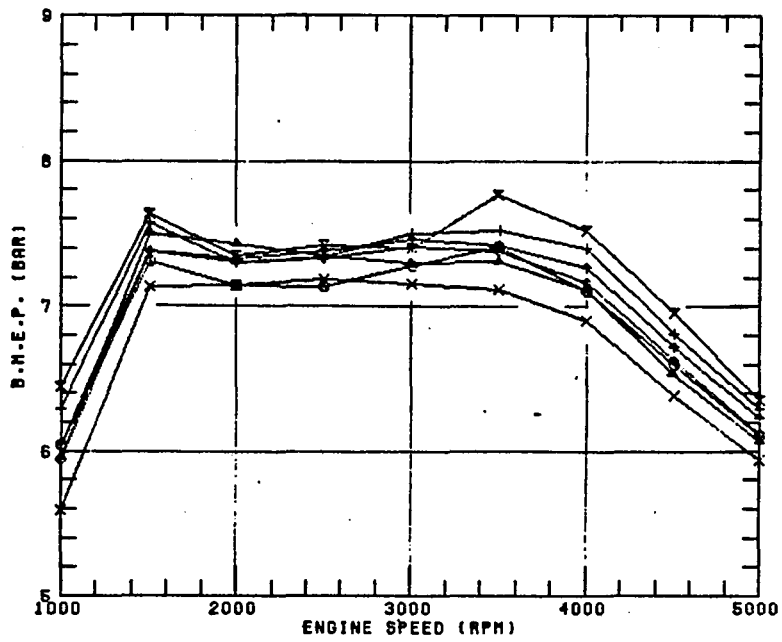
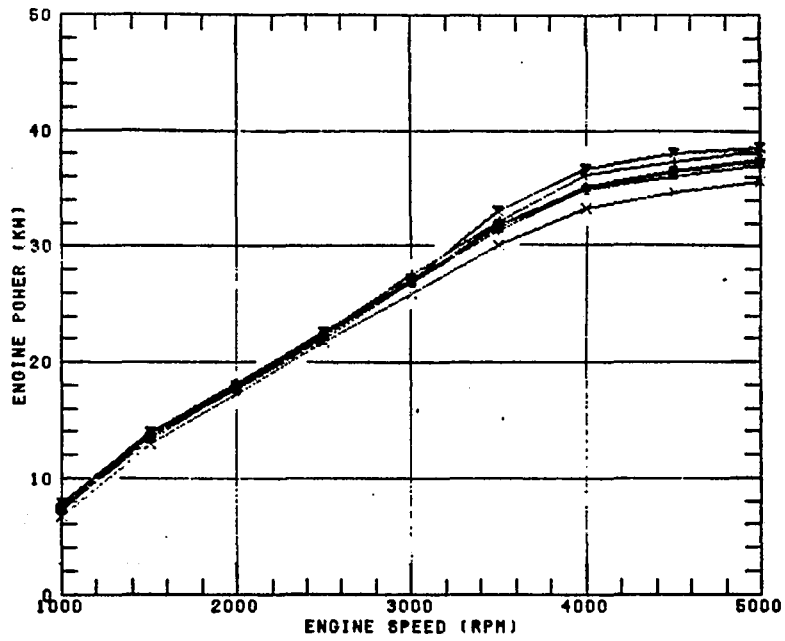

FULL LOAD: FUEL NUMBER/FUEL DENSITY

- 323/0.841 ◇ 16140/0.834
- ▲ 15275/0.840 † 16160/0.843
- + 16086/0.825 × 16164/0.869
- × 16120/0.817

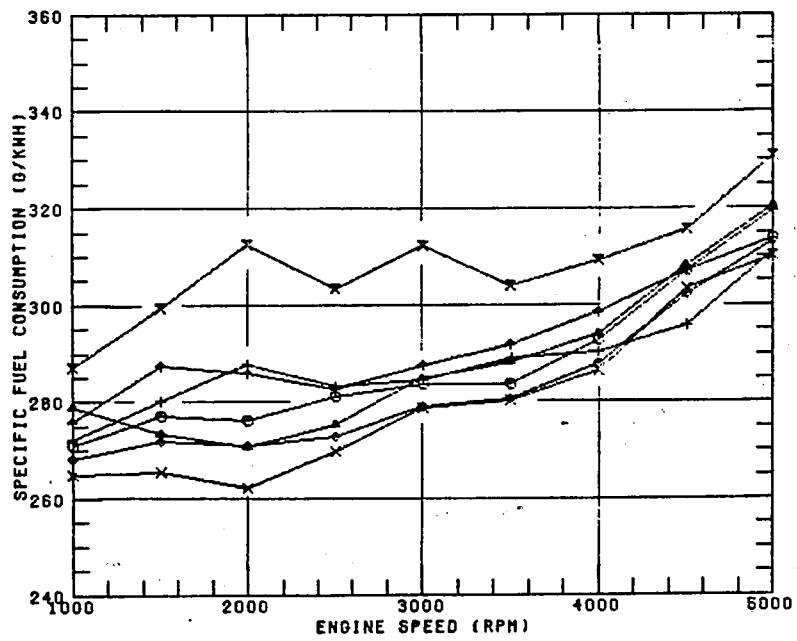
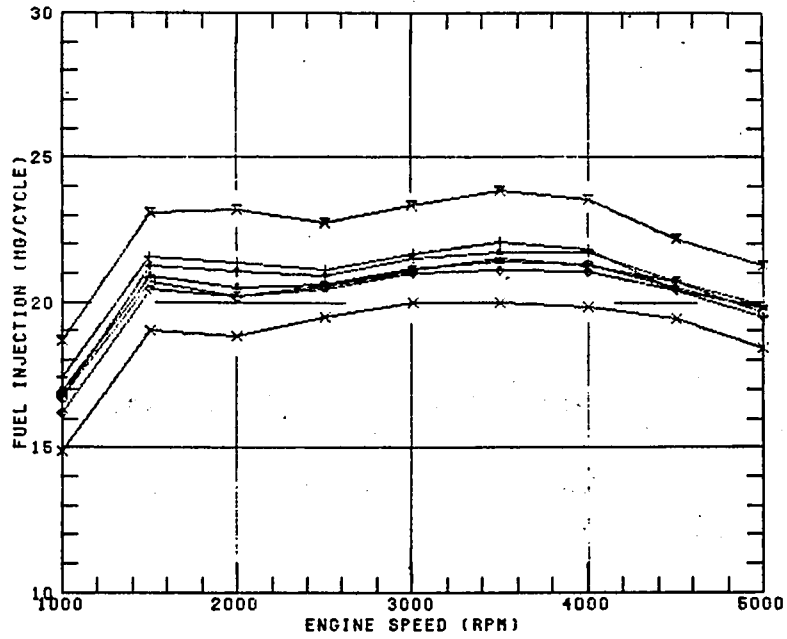

FULL LOAD: FUEL NUMBER/FUEL DENSITY

- 323/0.841 ◆ 16140/0.834
- ▲ 15275/0.840 ♣ 16160/0.843
- + 16086/0.825 × 16164/0.869
- × 16120/0.817

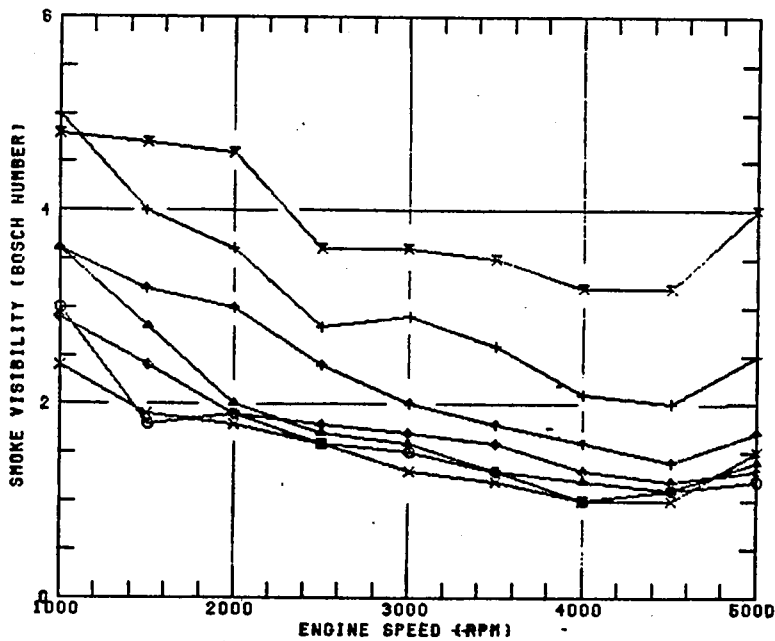
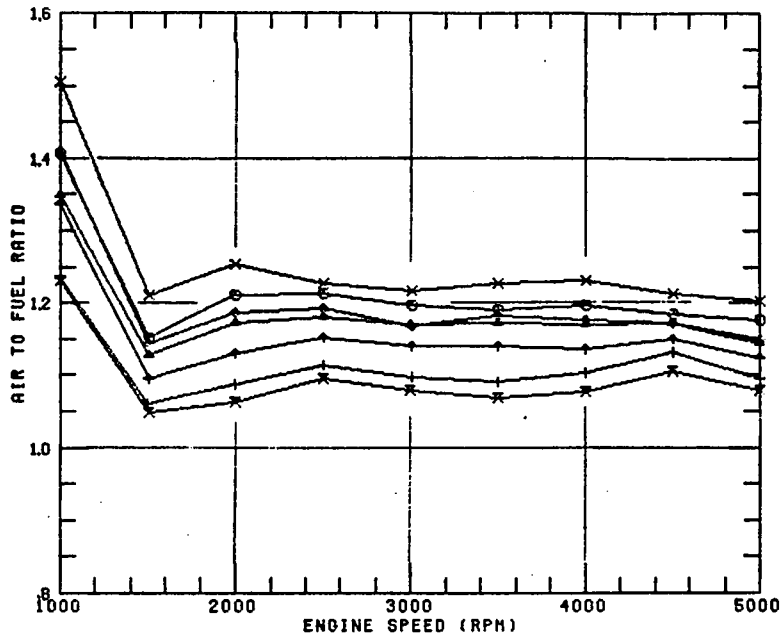

FULL LOAD: FUEL NUMBER/FUEL DENSITY

- 323/0.841 ◇ 16140/0.834
- ▲ 15275/0.840 ♣ 16160/0.843
- + 16086/0.825 × 16164/0.869
- × 16120/0.817

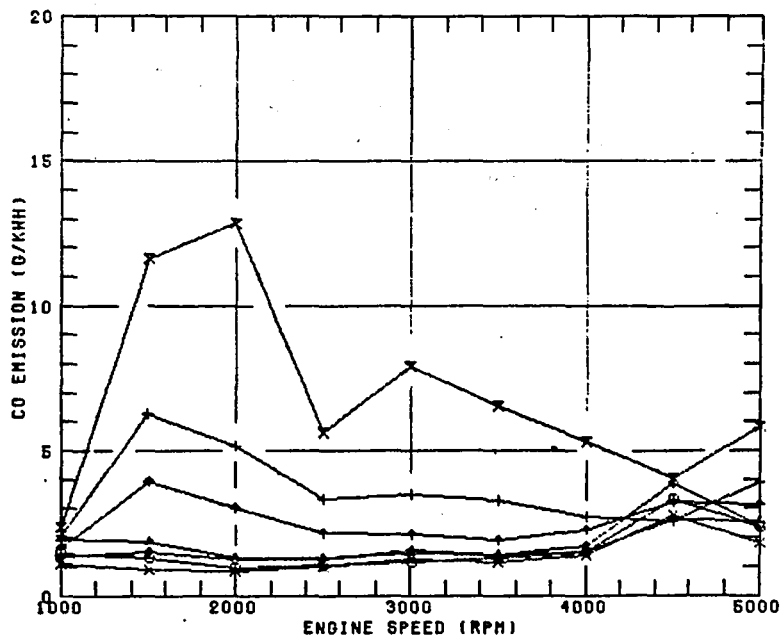
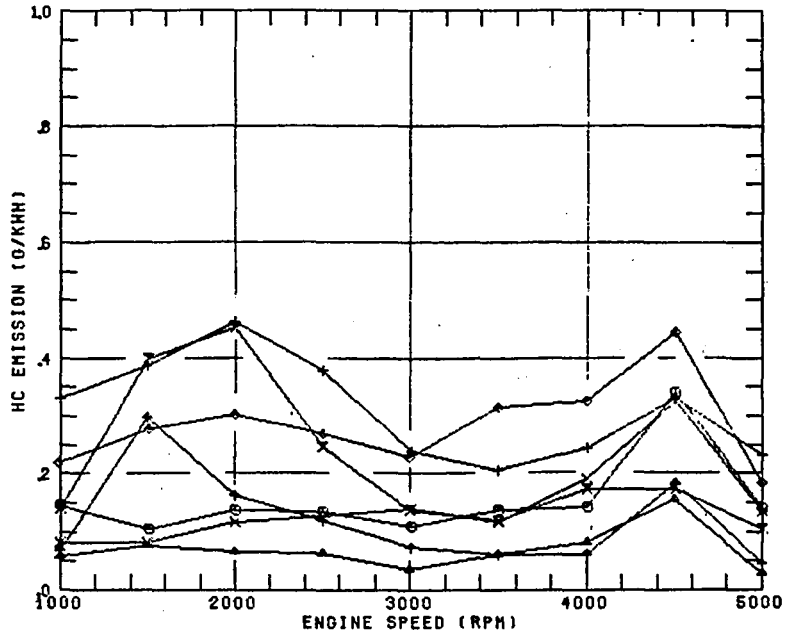

FULL LOAD: FUEL NUMBER/FUEL DENSITY

- | | |
|---------------|---------------|
| ⊙ 323/0.841 | ◇ 16140/0.834 |
| △ 15275/0.840 | ↑ 16160/0.843 |
| + 16086/0.825 | × 16164/0.869 |
| × 16120/0.817 | |

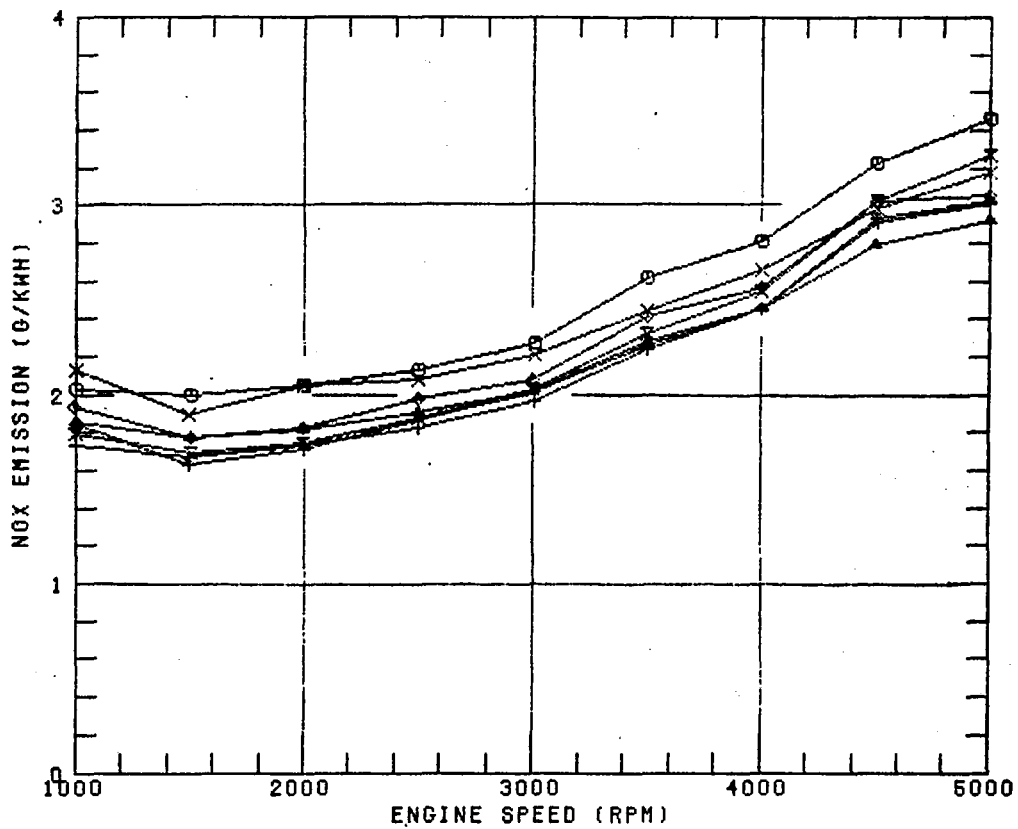

ROAD LOAD CURVES

2250 LB VEHICLE		3000 LB VEHICLE	
x	70 HP TC E.G.R.	z	8 CYLINDER 180 CID N.A.
+	70 HP TC DIESEL	x	6 CYLINDER 146 CID TC
▲	50 HP N.A. E.G.R.	◆	6 CYLINDER 146 CID N.A.
○	50 HP N.A. DIESEL	◊	6 CYLINDER 130 CID N.A.

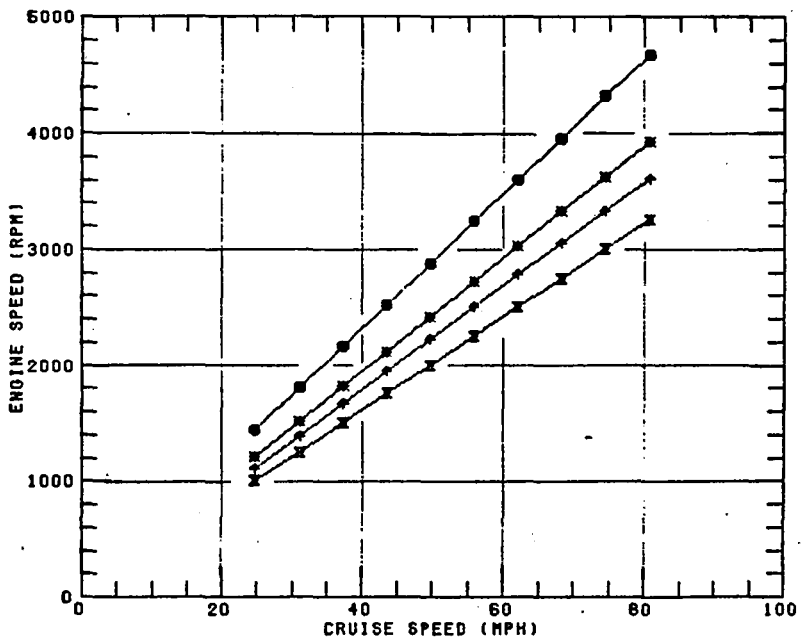
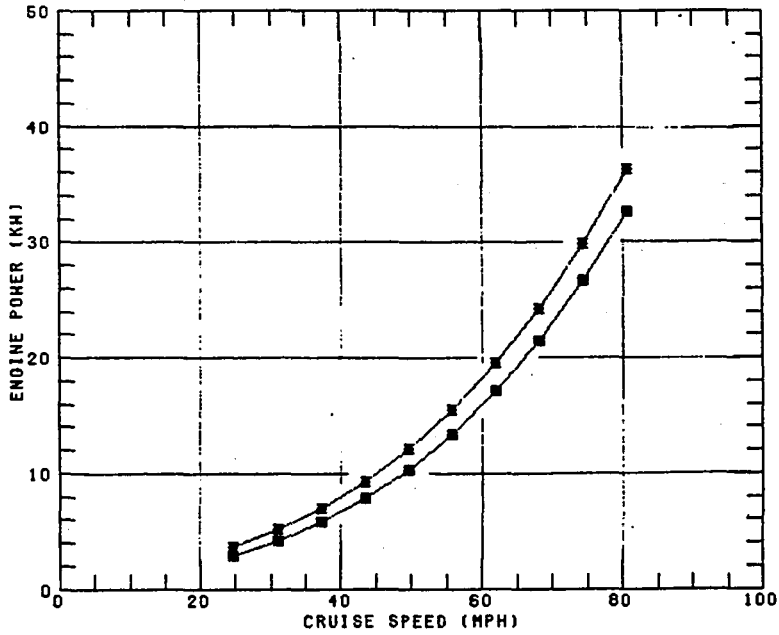

Z	77400SCHD1	1362	1.75	0.80	40.0
X	77400SCHL1	1362	1.75	0.80	40.0
+	31904DRSZ6	1362	1.75	0.80	36.0
◇	72000SCHF1	1362	1.75	0.80	33.1
X	77400SCHAB	1020	1.75	0.77	33.1
+	77400SCHL1	1020	1.75	0.77	33.1
▲	77400SCHAA	1020	1.75	0.77	27.8
○	77400SCHD1	1020	1.75	0.77	27.8

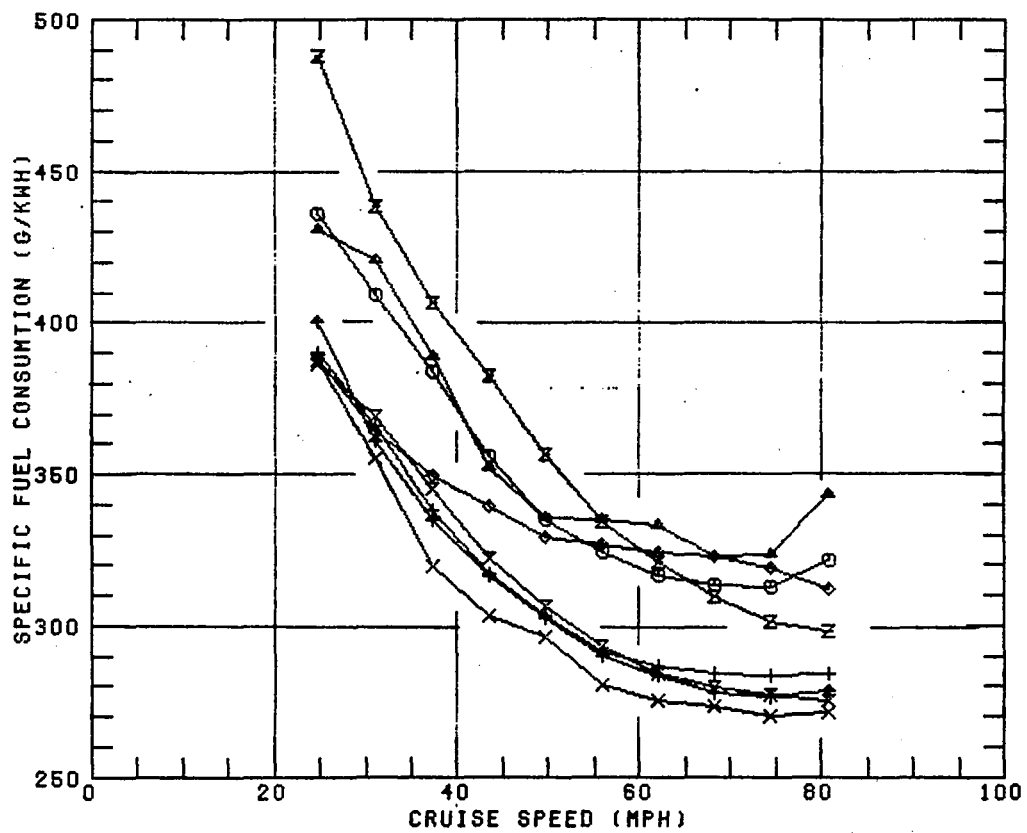

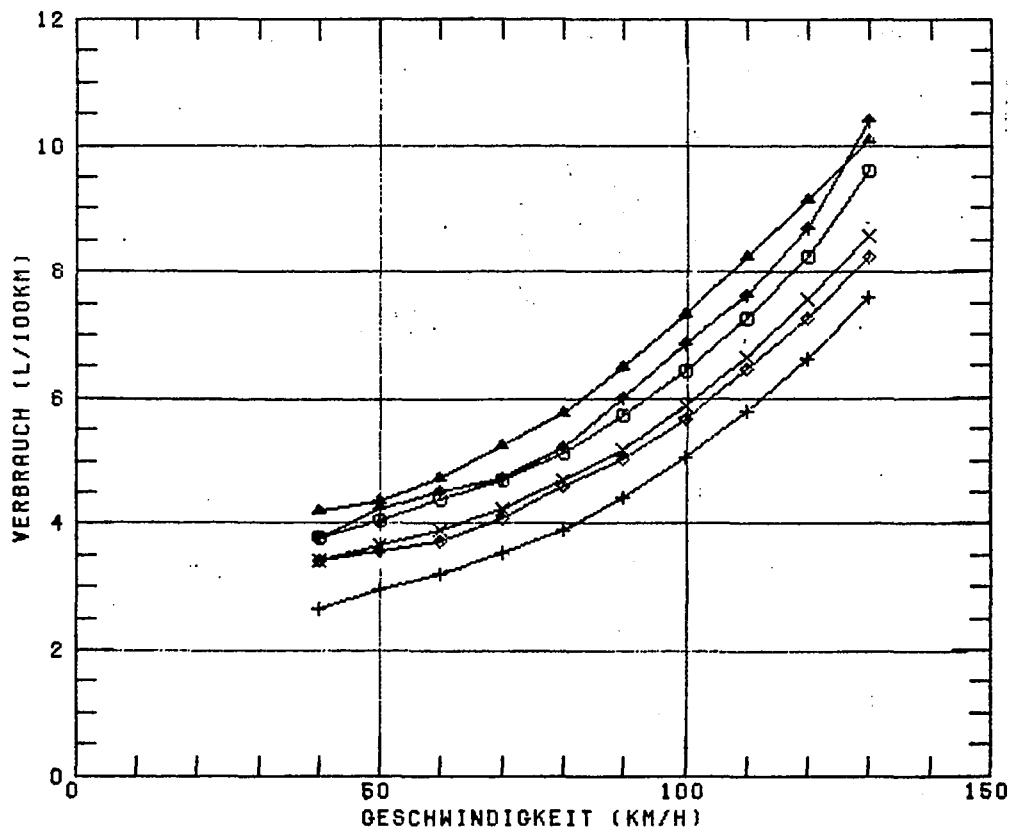

						ROAD LOAD
▲	77400SCHRA2	1020	1.75	0.77	27.8	60 HP N.A. PRODUCTION DIESEL WITH E.G.R.
◊	77400SCHR2	1020	1.75	0.77	33.1	70 HP TC RESEARCH DIESEL WITH E.G.R.
+	77400SCHL1	1020	1.75	0.77	33.1	70 HP TC RESEARCH DIESEL 5 SPEED TRANSM.
×	77400SCHL1	1020	1.25	0.77	42.9	70 HP TC RESEARCH DIESEL
▲	72000SCHF1	1250	1.75	0.77	33.1	5 CYLINDER 130 CID N.A. DIESEL
⊙	77400SCHD1	1020	1.75	0.77	27.8	60 HP N.A. PRODUCTION DIESEL

ROAD LOAD CURVES

2250 LB VEHICLE		3000 LB VEHICLE	
x	70 HP TC E.O.R	z	8 CYLINDER 180 CID N.A.
+	70 HP TC DIESEL	x	6 CYLINDER 146 CID TC
▲	50 HP N.A. E.O.R.	◆	6 CYLINDER 146 CID N.A.
○	50 HP N.A. DIESEL	◆	6 CYLINDER 130 CID N.A.

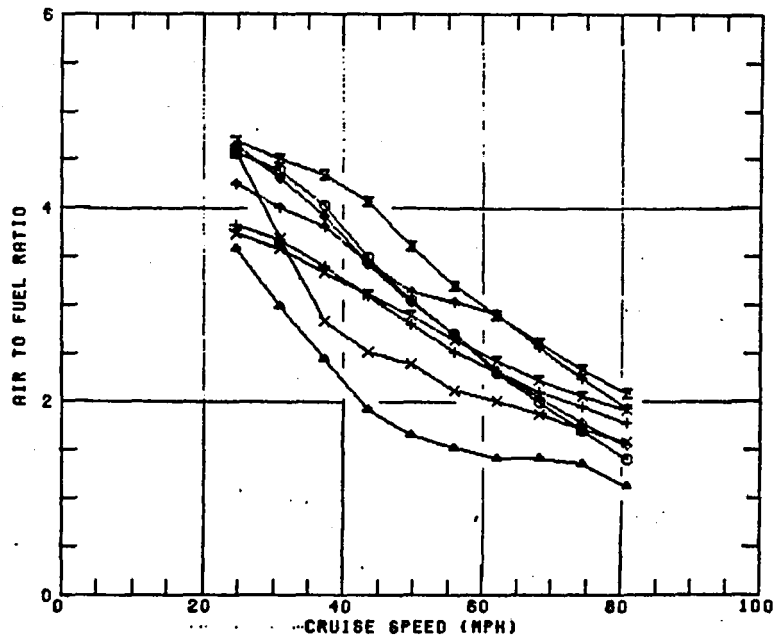
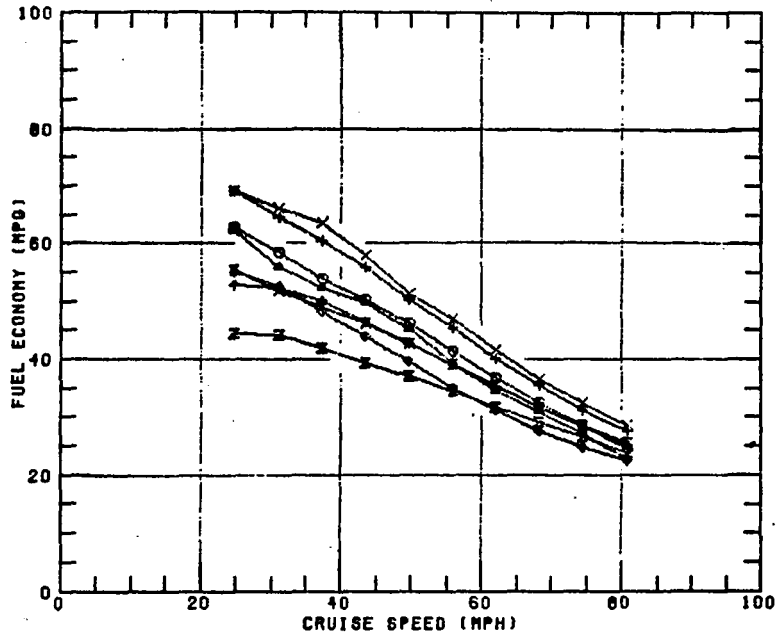

ROAD LOAD CURVES

2250 LB VEHICLE		3000 LB VEHICLE	
x	70 HP TC E.O.R	z	6 CYLINDER 180 CID N.A.
+	70 HP TC DIESEL	x	6 CYLINDER 146 CID TC
▲	60 HP N.A. E.O.R.	+	6 CYLINDER 146 CID N.A.
○	60 HP N.A. DIESEL	◆	6 CYLINDER 130 CID N.A.

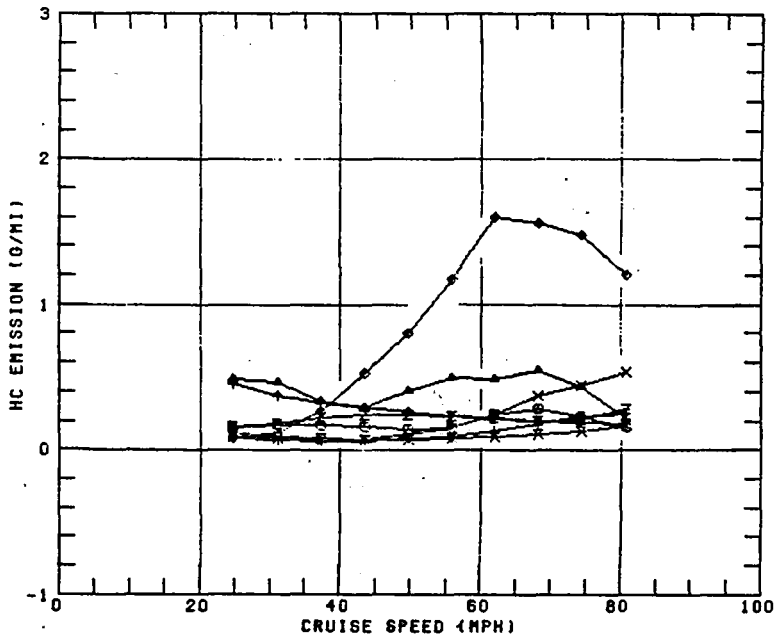
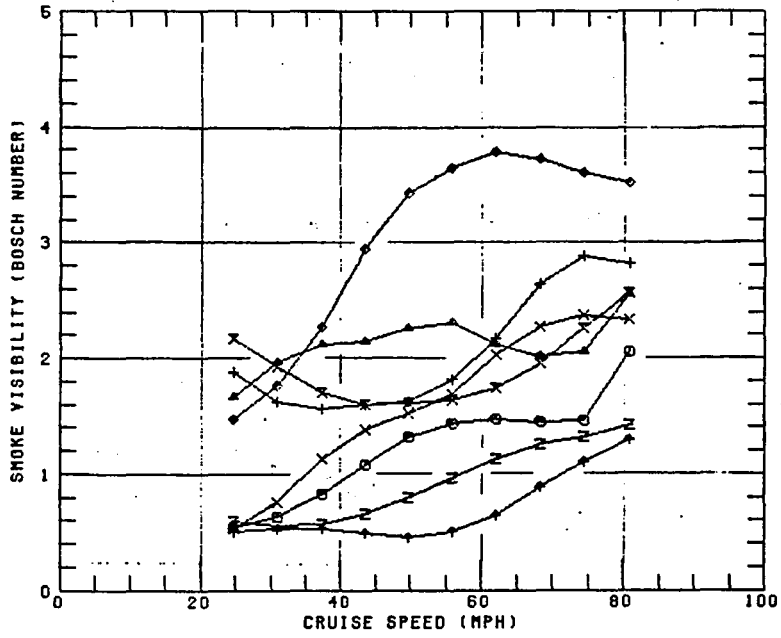

ROAD LOAD CURVES

2250 LB VEHICLE		3000 LB VEHICLE	
x	70 HP TC E.O.R	z	8 CYLINDER 180 CID N.A.
+	70 HP TC DIESEL	x	6 CYLINDER 146 CID TC
▲	50 HP N.A. E.O.R.	◆	6 CYLINDER 146 CID N.A.
○	50 HP N.A. DIESEL	◆	6 CYLINDER 130 CID N.A.

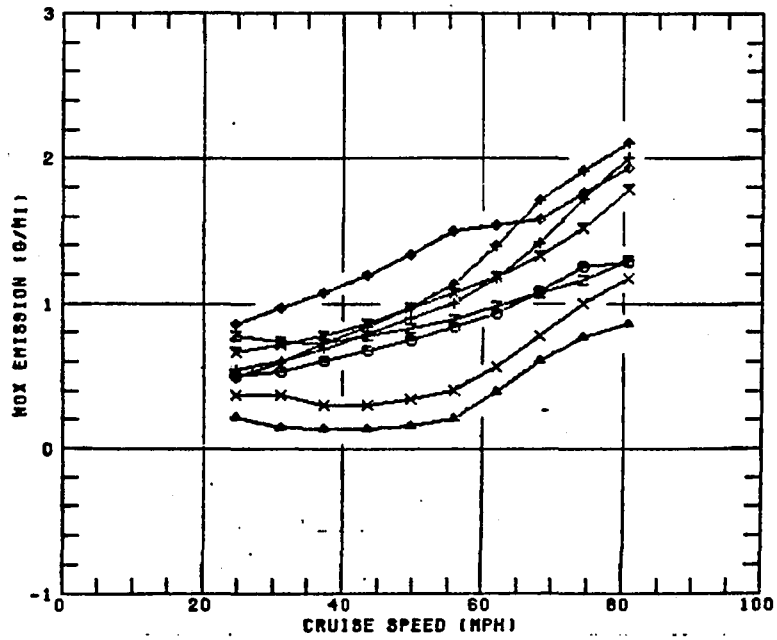
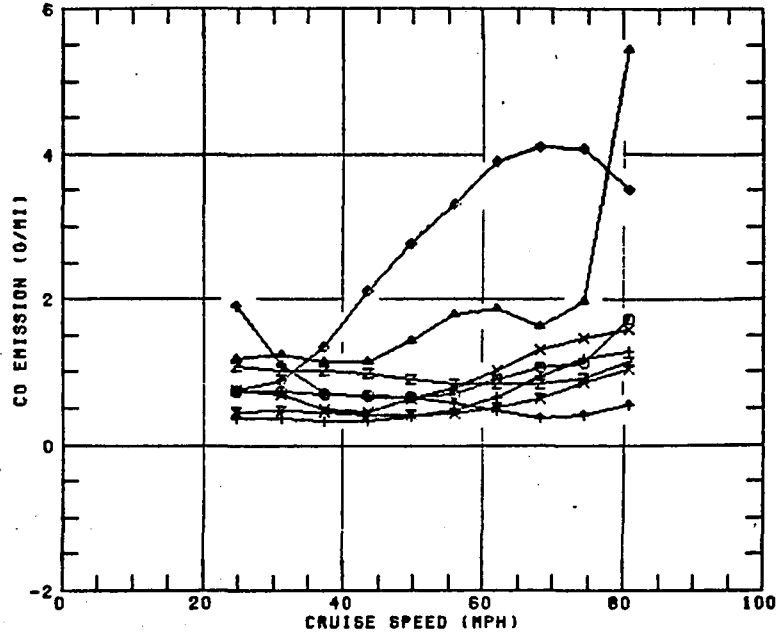

ROAD LOAD: FUEL NUMBER/FUEL DENSITY

- 323/0.841 ◇ 16140/0.834
- ▲ 15275/0.840 † 16160/0.843
- + 16086/0.826 × 16164/0.869
- × 16120/0.817

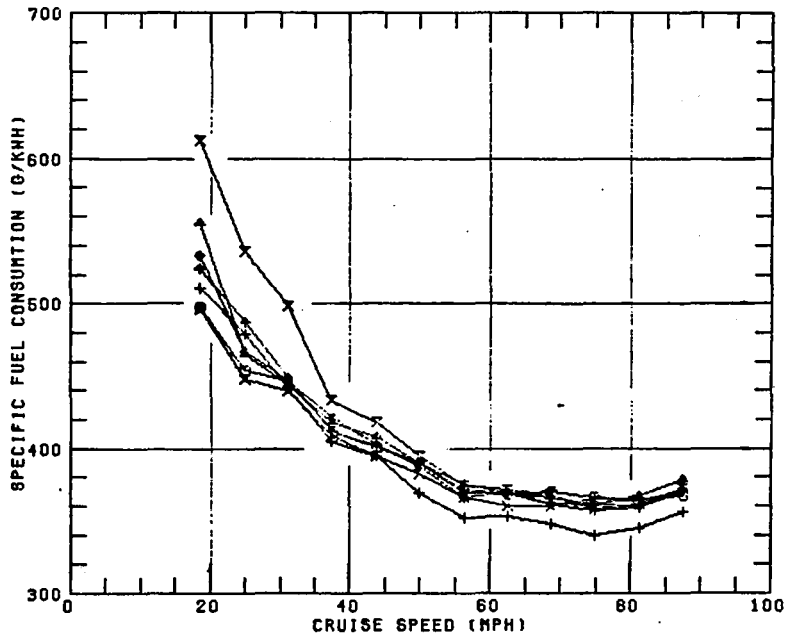
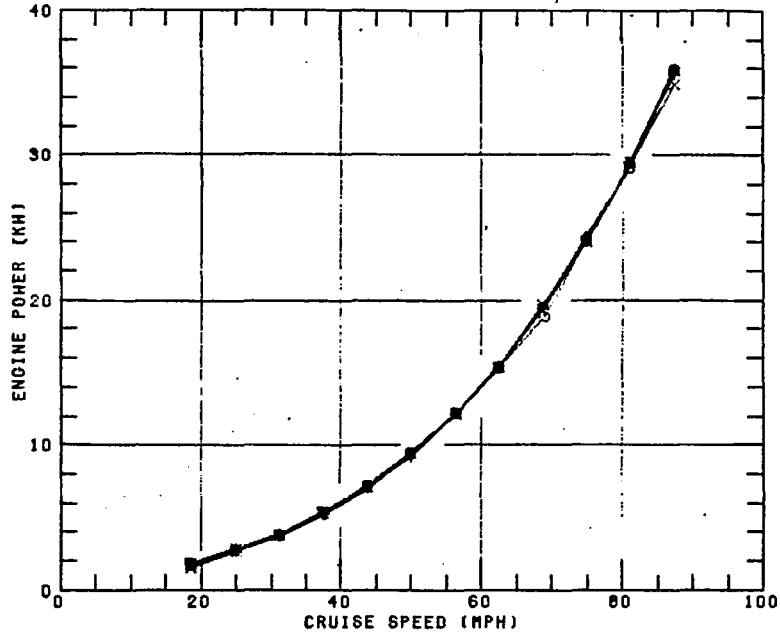

ROAD LOAD: FUEL NUMBER/FUEL DENSITY

- | | |
|---------------|---------------|
| ○ 323/0.841 | ◇ 16140/0.834 |
| ▲ 15275/0.840 | ♣ 16160/0.843 |
| + 16086/0.825 | × 16164/0.869 |
| × 16120/0.817 | |

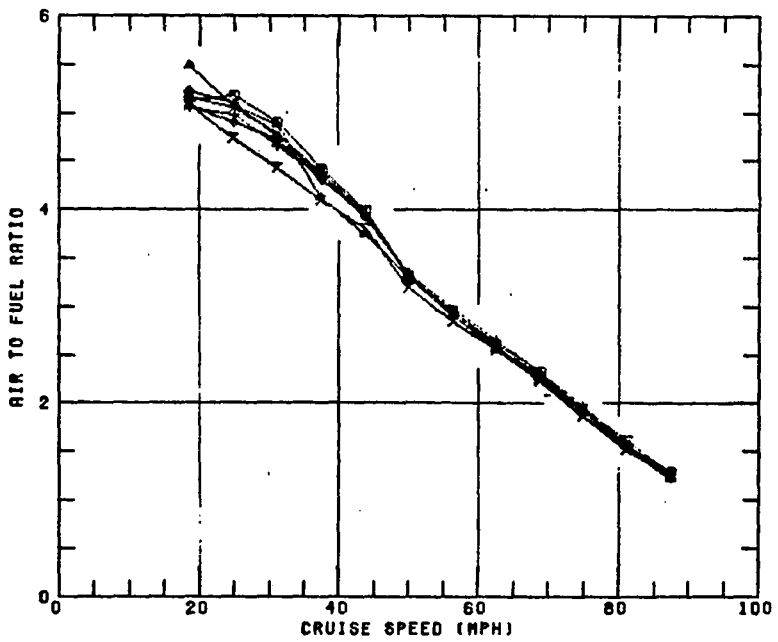
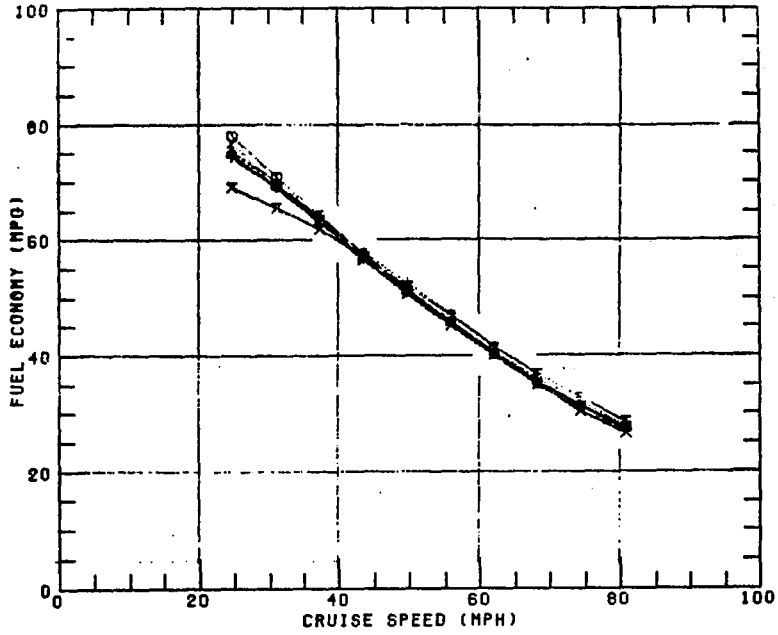

ROAD LOAD: FUEL NUMBER/FUEL DENSITY

- 323/0.841 ◇ 16140/0.834
- ▲ 15275/0.840 ◆ 16160/0.843
- + 16086/0.825 × 16164/0.869
- × 16120/0.817

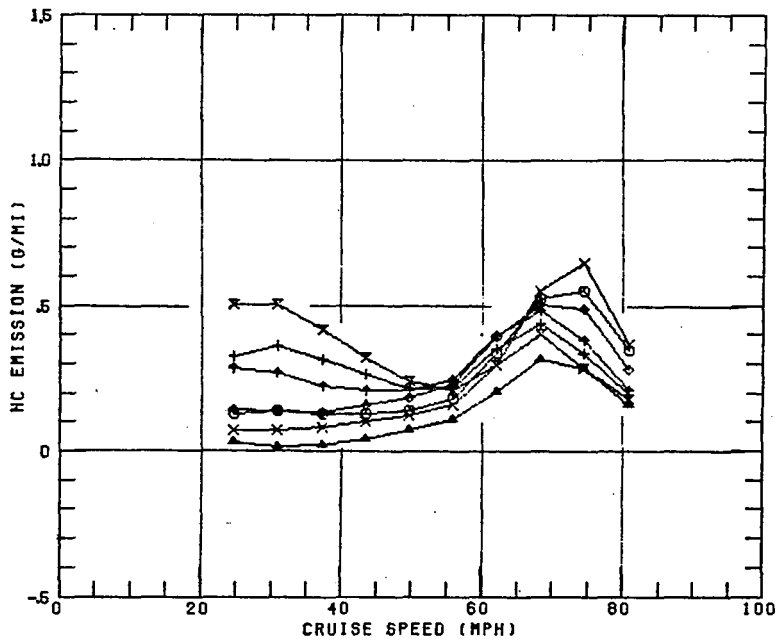
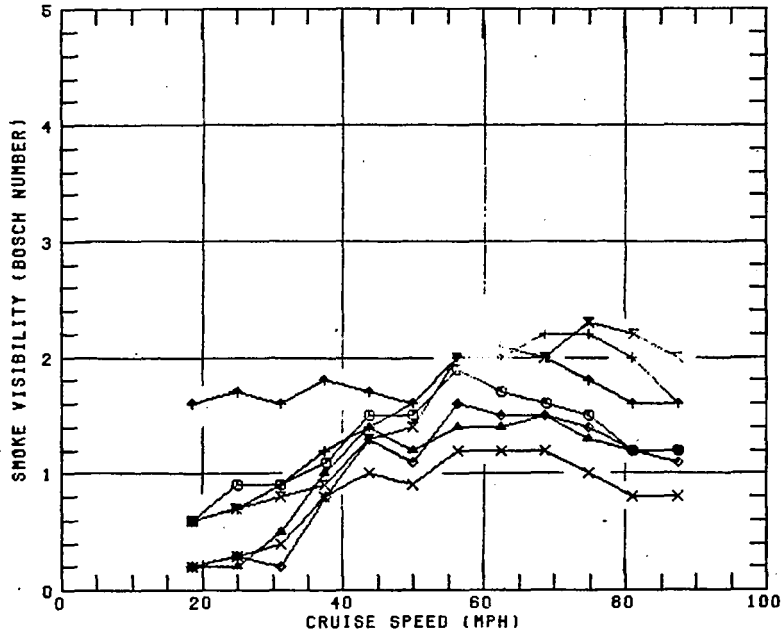

ROAD LOAD: FUEL NUMBER/FUEL DENSITY
 ○ 329/0.841 ◆ 16140/0.834
 ▲ 16276/0.840 ♣ 16160/0.843
 + 16086/0.825 × 16164/0.868
 × 16120/0.817

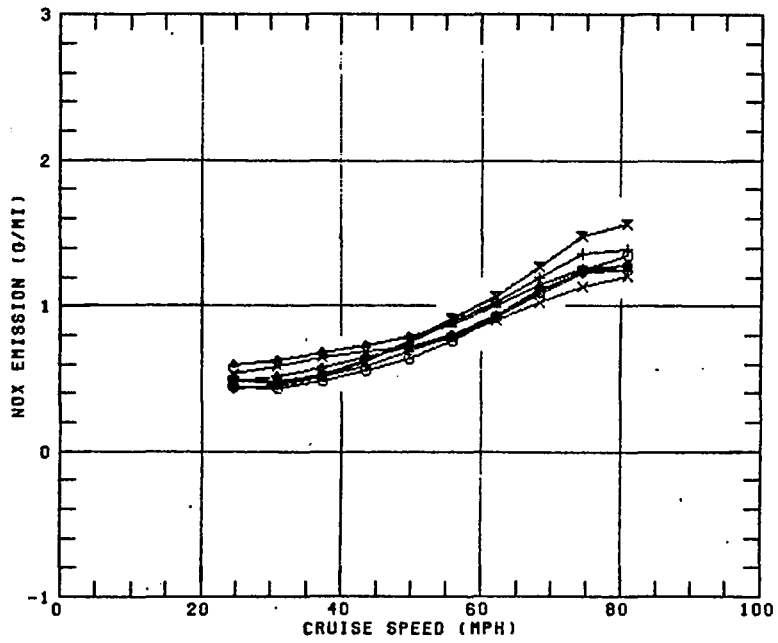
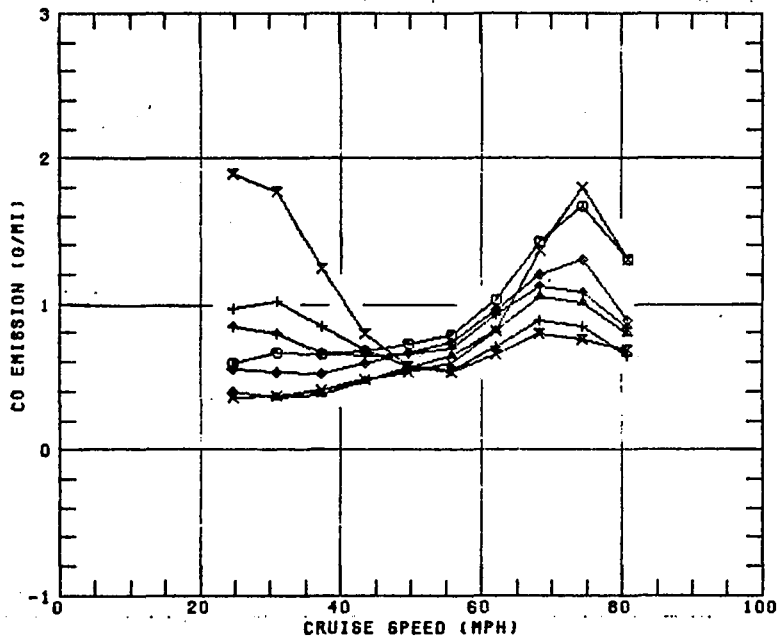

50 HP N.A. 90 CID

FUEL CONSUMPTION (KG/H)

1372.0 SEC US-CITY TEST DATE 07/10/76 13.47.33

TEST RESULT 615.04 G/ 7.45 MI = 38.60 MPG

SHADED REGIONS 310.43 71.67 M

VEHICLE 1020 KG MASS, 0.80 SQM CW*F, 1.75 % ROLLING DRAG
TRANSMISSION AXLE/GEAR COMBINATION NO. 3

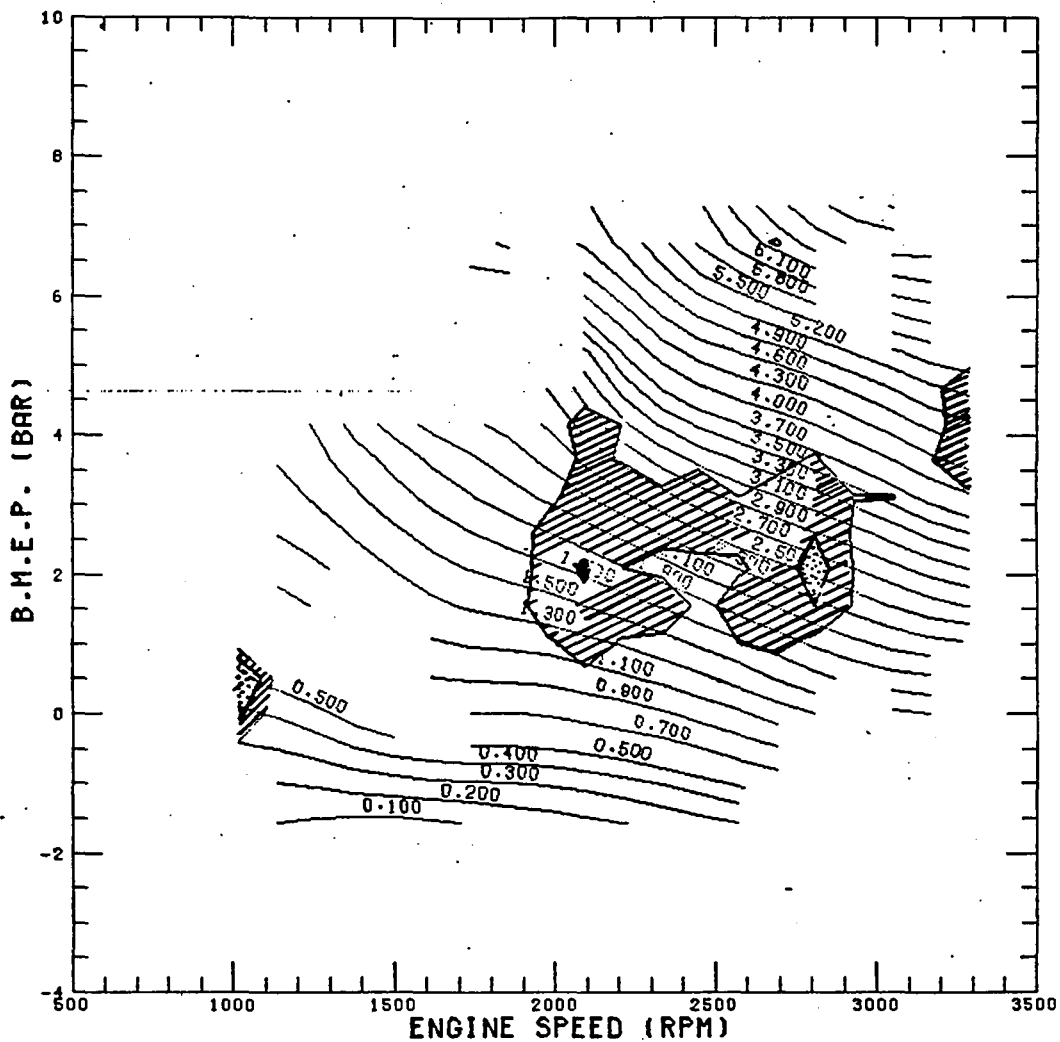

50 HP N.A. 90 CID

AIR TO FUEL RATIO

1372.0 SEC US-CITY TEST DATE 07/10/76 13.47.33

TEST RESULT 1372.25 S/ 7.45 MI = 19.54 MPH

SHADED REGIONS 682-87 194.37 M

VEHICLE 1020 KG MASS. 0.80 SQM CM²F. 1.75 % ROLLING DRAG

TRANSMISSION AXLE/GEAR COMBINATION NO. 3

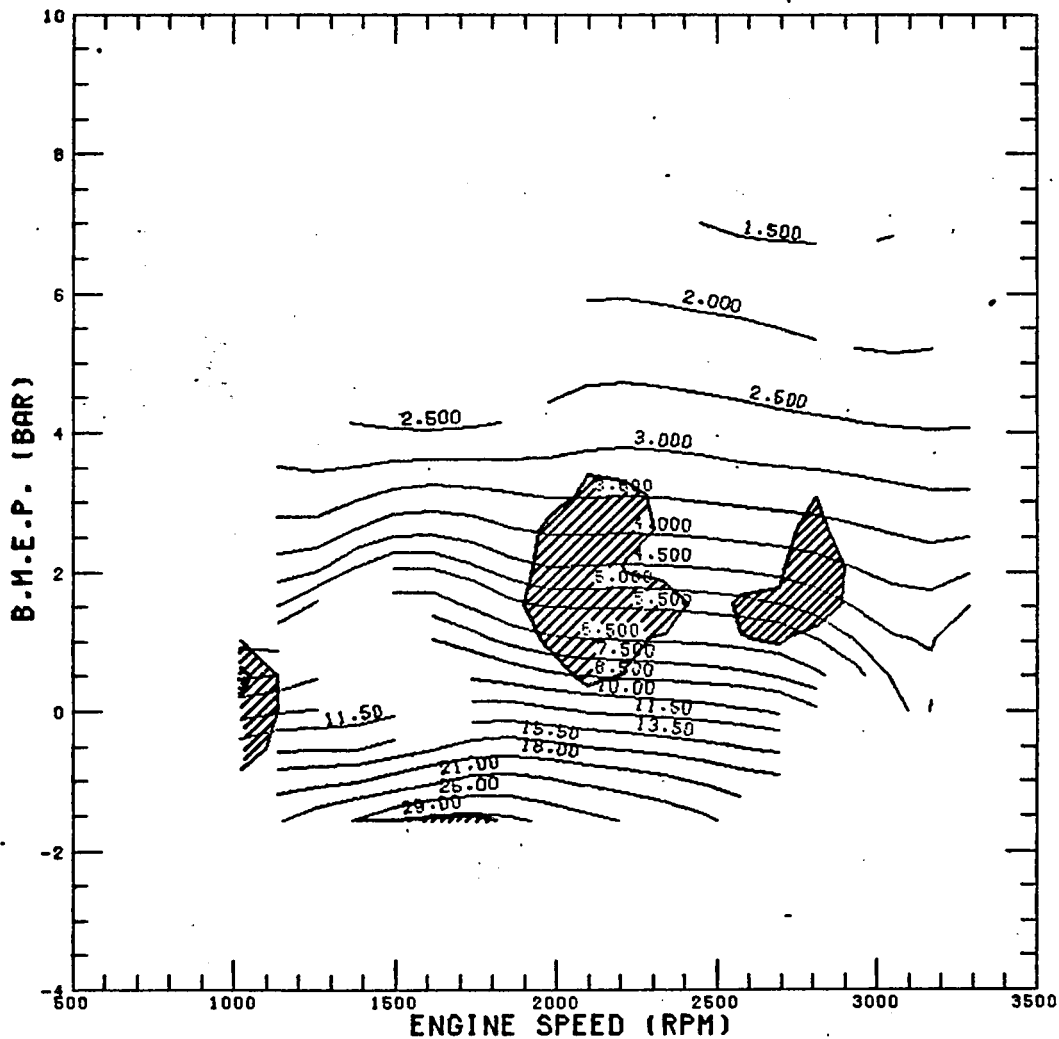

50 HP N.A. 90 CID

FUEL CONSUMPTION (KG/H)

1372.0 SEC US-CITY TEST DATE 07/10/76 13.47.33

TEST RESULT 615.04 G/ 7.45 MI = 38.60 MPG

SHADED REGIONS 310.43 71.67 M

VEHICLE 1020 KG MASS, 0.80 SQM CW*F, 1.75 % ROLLING DRAG
TRANSMISSION AXLE/GEAR COMBINATION NO. 3

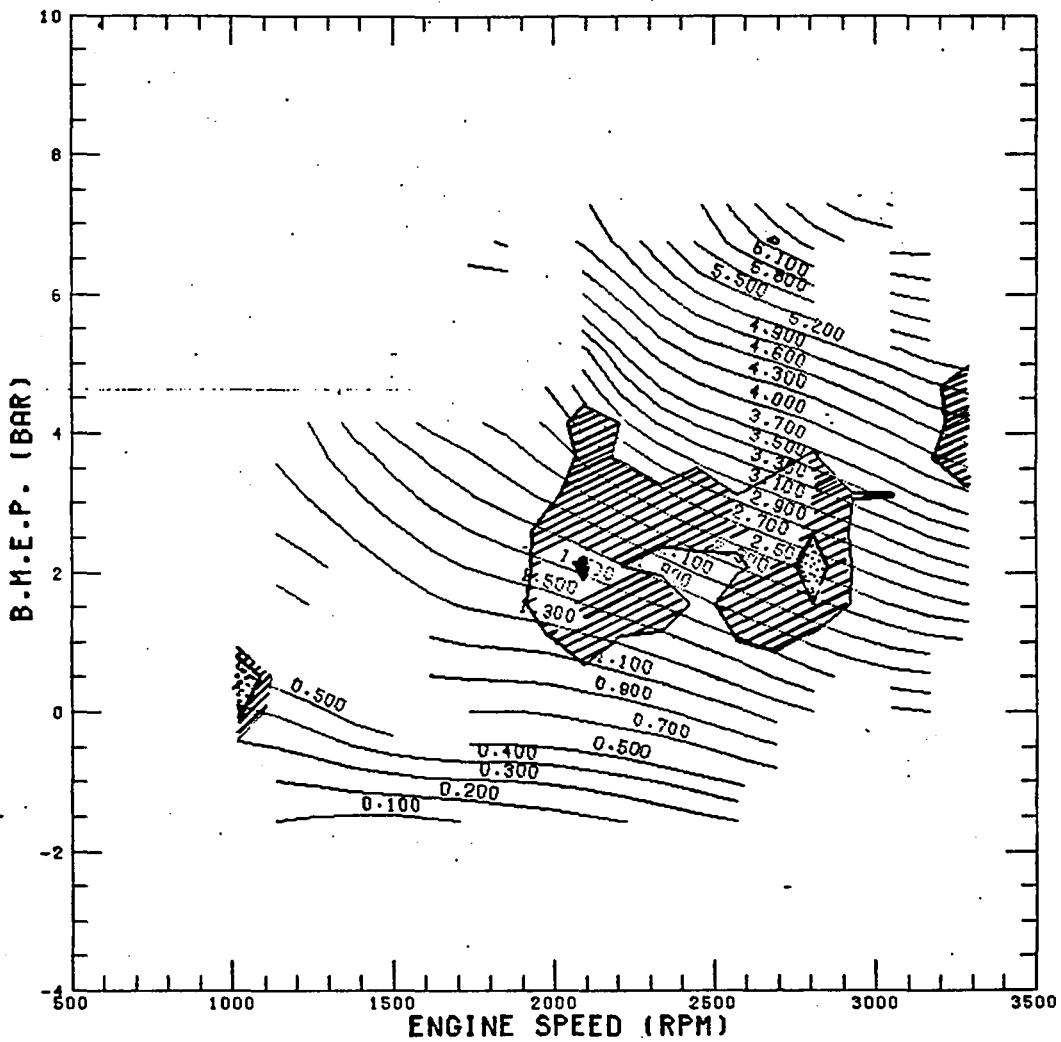

50 HP N.A. 90 CID

AIR TO FUEL RATIO

1372.0 SEC US-CITY TEST DATE 07/10/76 13.47.33

TEST RESULT 1372.25 S/ 7.45 MI = 19.54 MPH

SHADED REGIONS 682.87 194.37 M

VEHICLE 1020 KG MASS. 0.80 SQM CMWF. 1.75 % ROLLING DRAG
TRANSMISSION AXLE/GEAR COMBINATION NO. 3

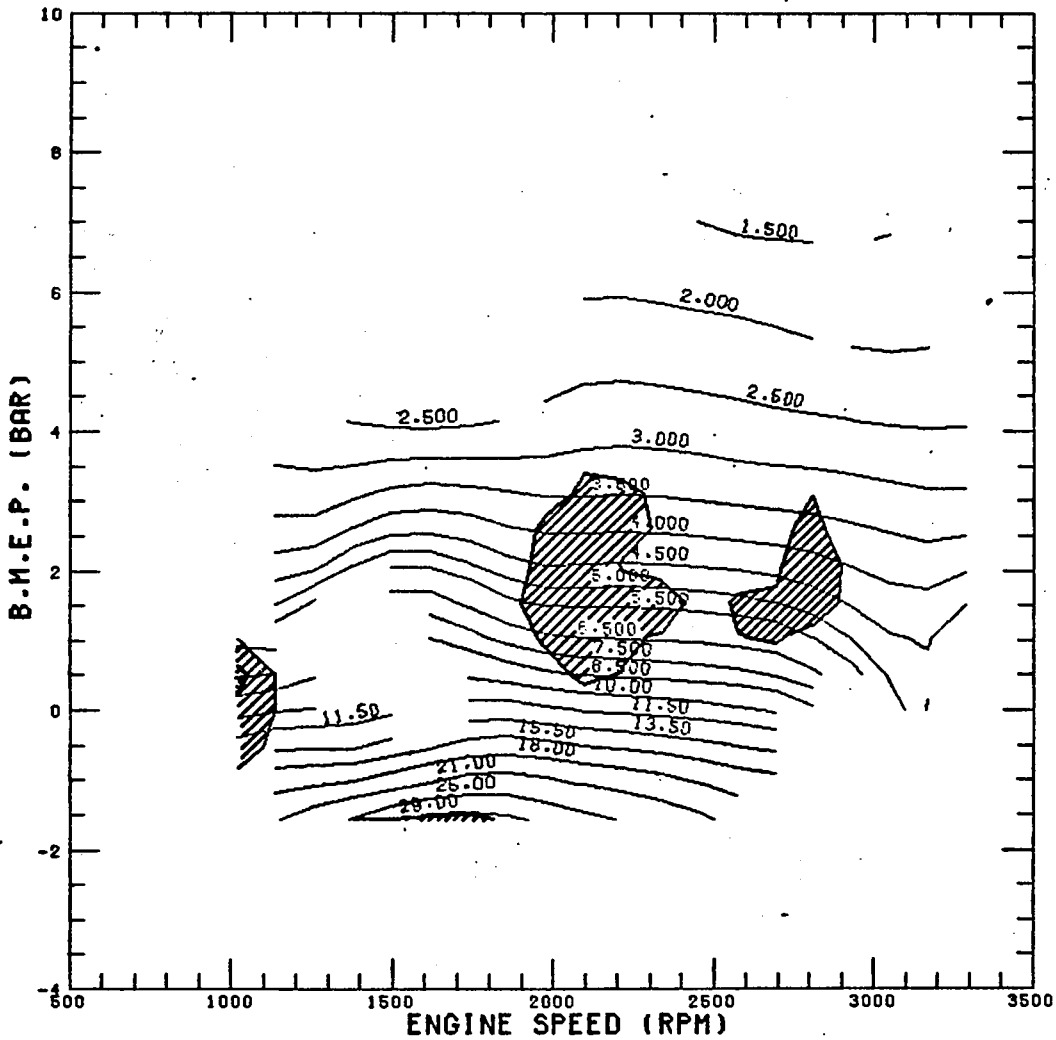

50 HP N.A. 90 CID

HC - EMISSION (G/H)

1372.0 SEC US-CITY TEST DATE 07/10/76 13.47.33

TEST RESULT 1.86 G/ 7.45 MI = 0.25 G/MI

SHADED REGIONS 0.94 0.14 G

VEHICLE 1020 KG MASS, 0.80 SDM CW*F, 1.75 % ROLLING DRAG
TRANSMISSION AXLE/GEAR COMBINATION NO. 3

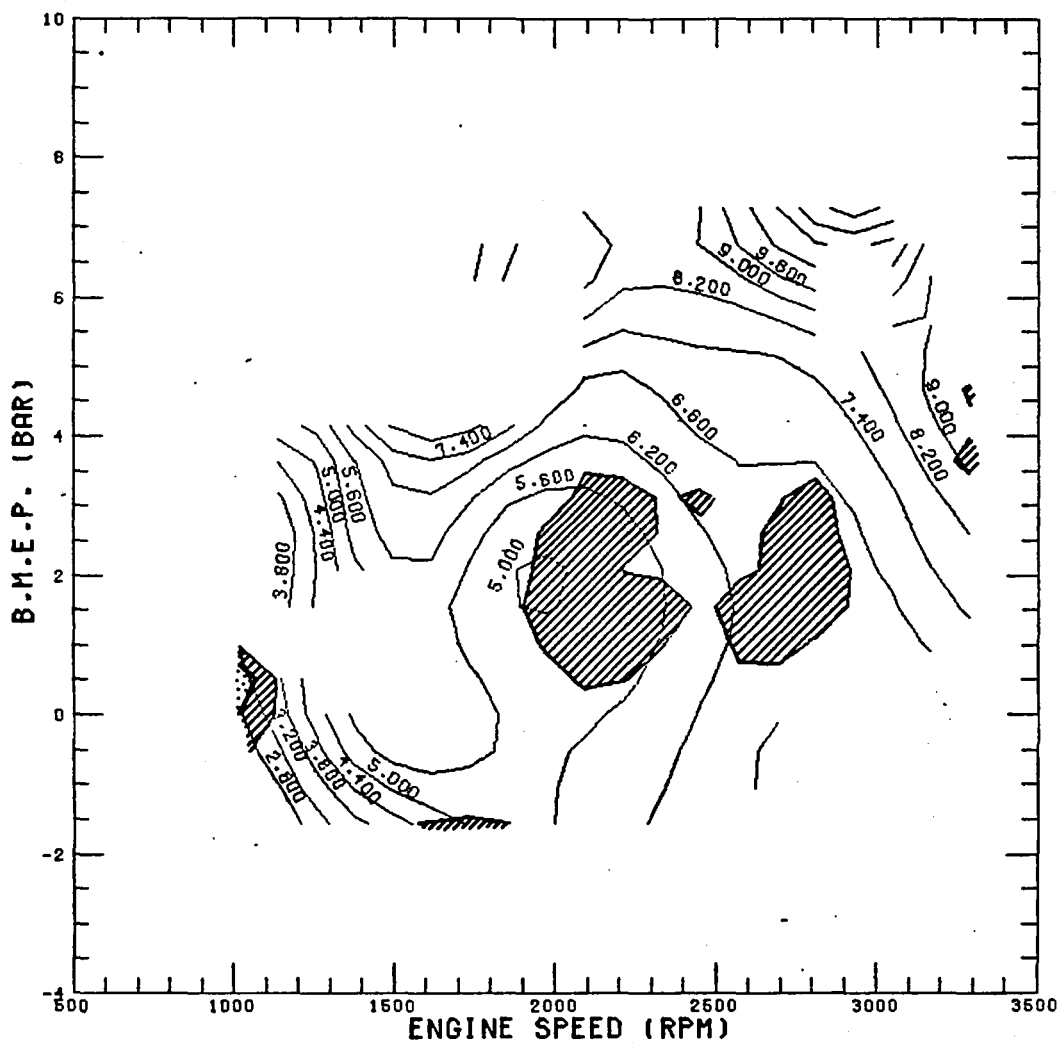

50 HP N.A. 90 CID

CO - EMISSION (G/H)

1372.0 SEC US-CITY TEST DATE 07/10/76 13.47.33

TEST RESULT 9.77 G/ 7.45 MI = 1.31 G/MI

SHADED REGIONS 4.84 1.30 G

VEHICLE 1020 KG MASS. 0.80 SQM CW*F. 1.75 % ROLLING DRAG
TRANSMISSION AXLE/GEAR COMBINATION NO. 3

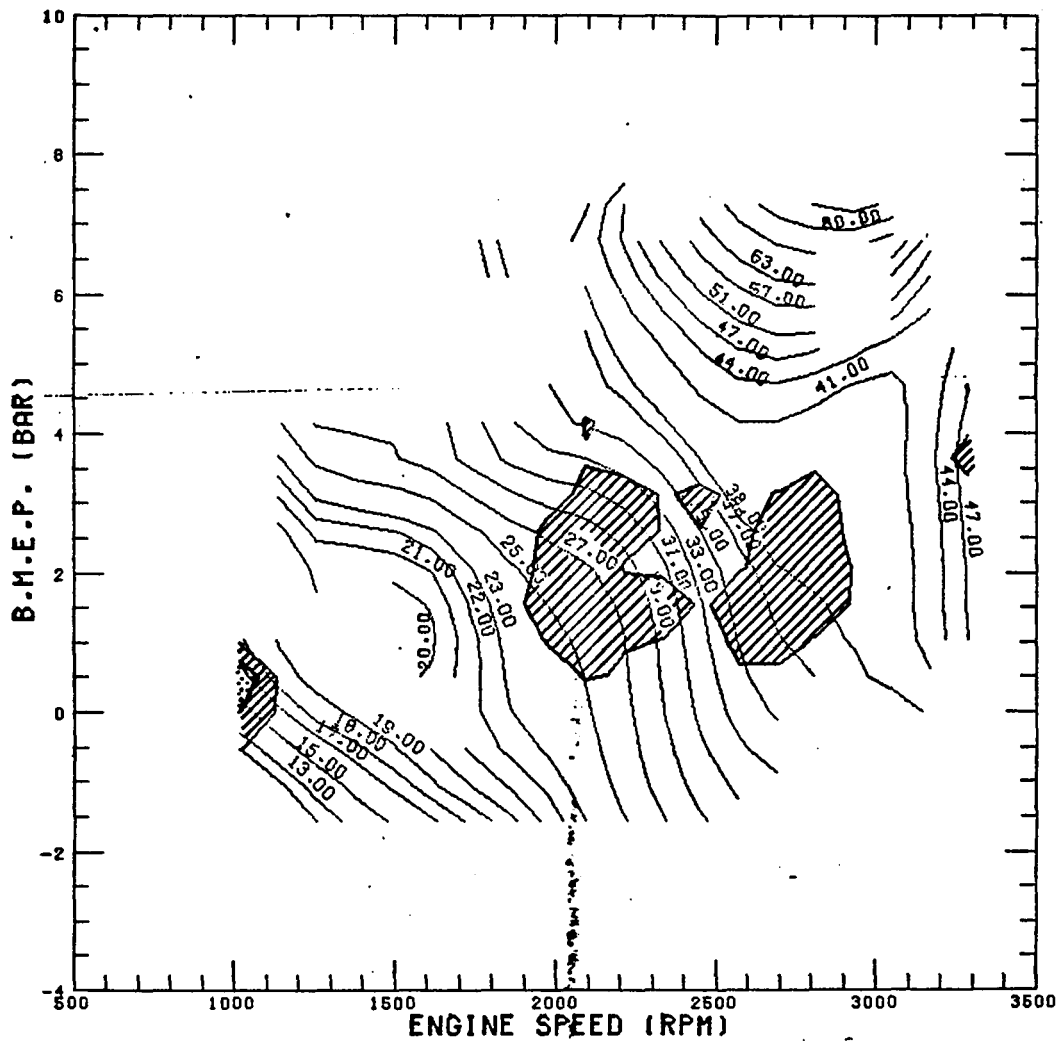

50 HP N.A. 90 CID

NOX - EMISSION (G/H)

1372.0 SEC US-CITY TEST DATE 07/10/76 13-47-33

TEST RESULT 5.58 G/ 7.45 MI = 0.75 G/MI

SHADED REGIONS 2.82 0.60 G

VEHICLE 1020 KG MASS, 0.80 SQM CW*F, 1.75 % ROLLING DRAG
TRANSMISSION AXLE/GEAR COMBINATION NO. 3

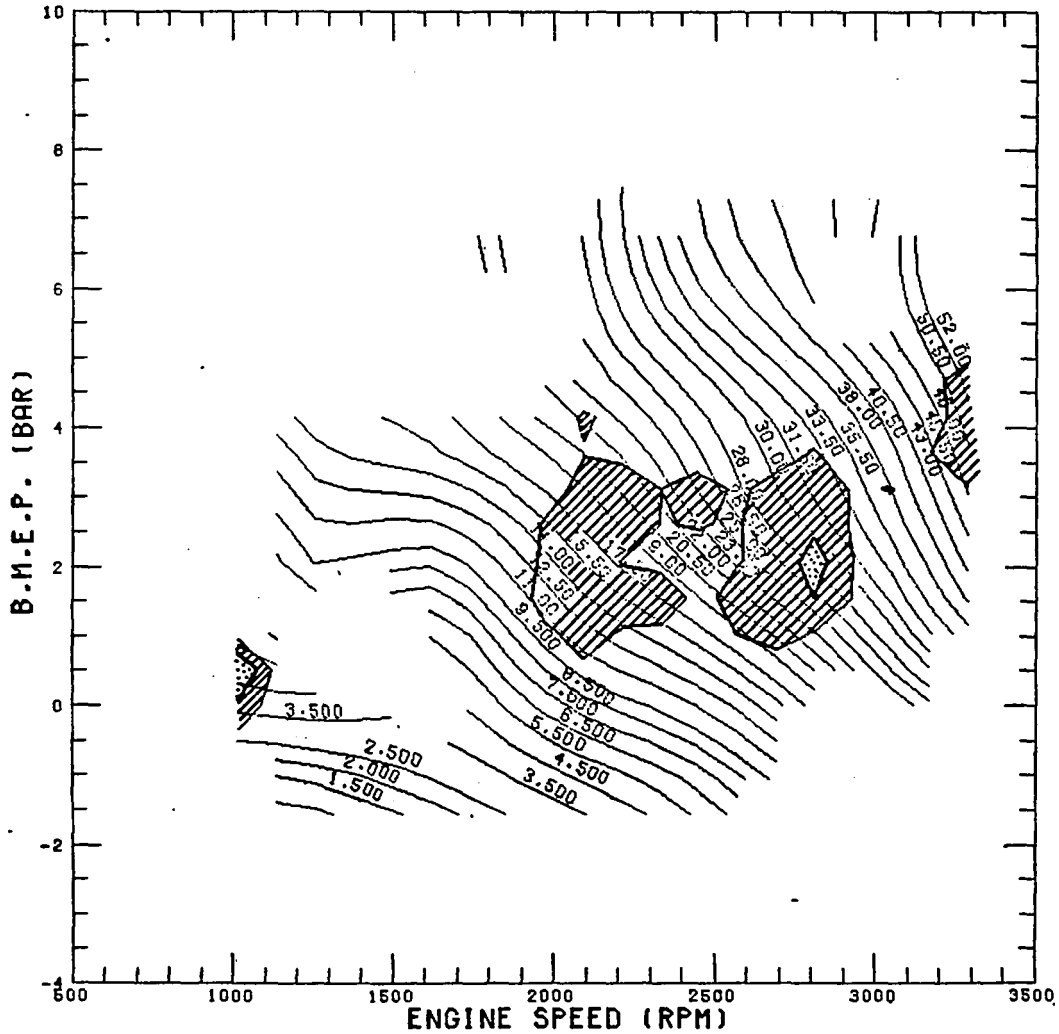

50 HP N.A. 90 CID

FUEL CONSUMPTION (KG/H)

764.0 SEC HIGHWAY TEST DATE 07/10/76 14.30.52

TEST RESULT 772.33 G/ 10.25 MI = 42.30 MPG

SHADED REGIONS 397.16 83.86 M

VEHICLE 1020 KG MASS, 0.80 SQM CH²F, 1.75 % ROLLING DRAG
TRANSMISSION AXLE/GEAR COMBINATION NO. 3

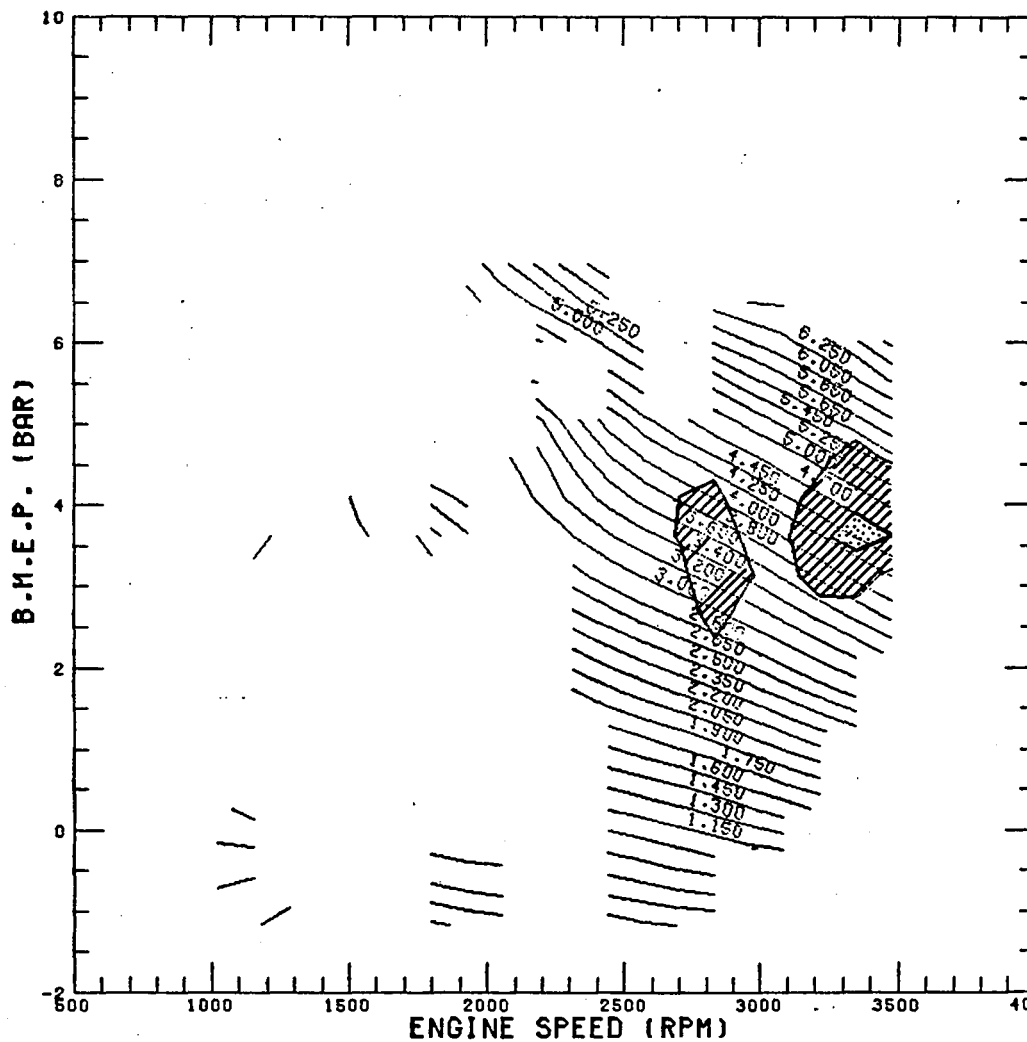

50 HP N.A. 90 CID

AIR TO FUEL RATIO

764.0 SEC HIGHWAY TEST DATE 07/10/76 14.30.52

TEST RESULT 764.25 S/ 10.25 MI = 48.28 MPH

SHADED REGIONS 386.25 73.62 M

VEHICLE 1020 KG MASS. 0.80 SQM CW=F. 1.75 % ROLLING DRAG
TRANSMISSION AXLE/GEAR COMBINATION NO. 3

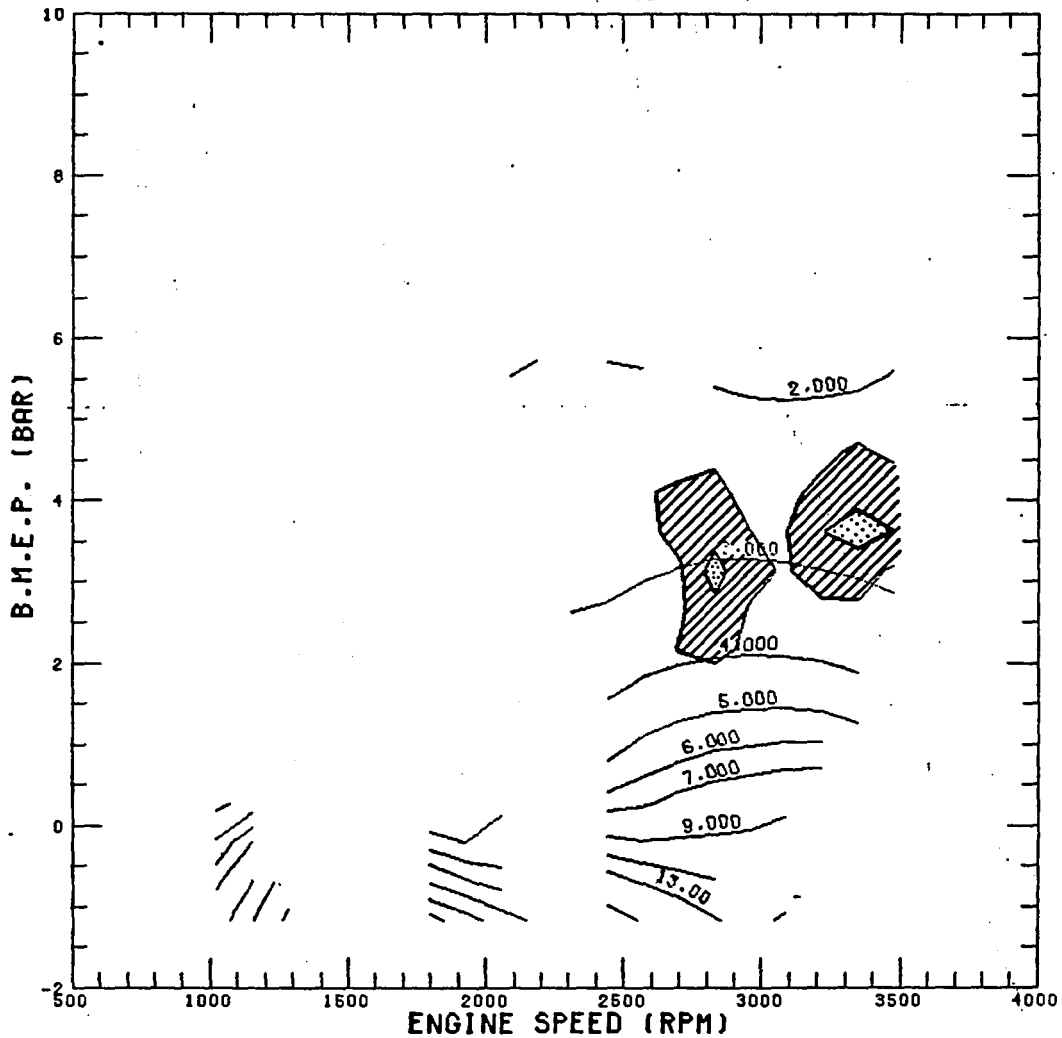

50 HP N.A. 90 CID

HC - EMISSION (G/H)

764.0 SEC HIGHWAY TEST DATE 07/10/76 14.30.52

TEST RESULT 1.96 G/ 10.25 MI = 0.19 G/MI

SHADED REGIONS 0.99 0.21 G

VEHICLE 1020 KG MASS. 0.80 SQM CWAF. 1.75 % ROLLING DRAG
TRANSMISSION AXLE/GEAR COMBINATION NO. 3

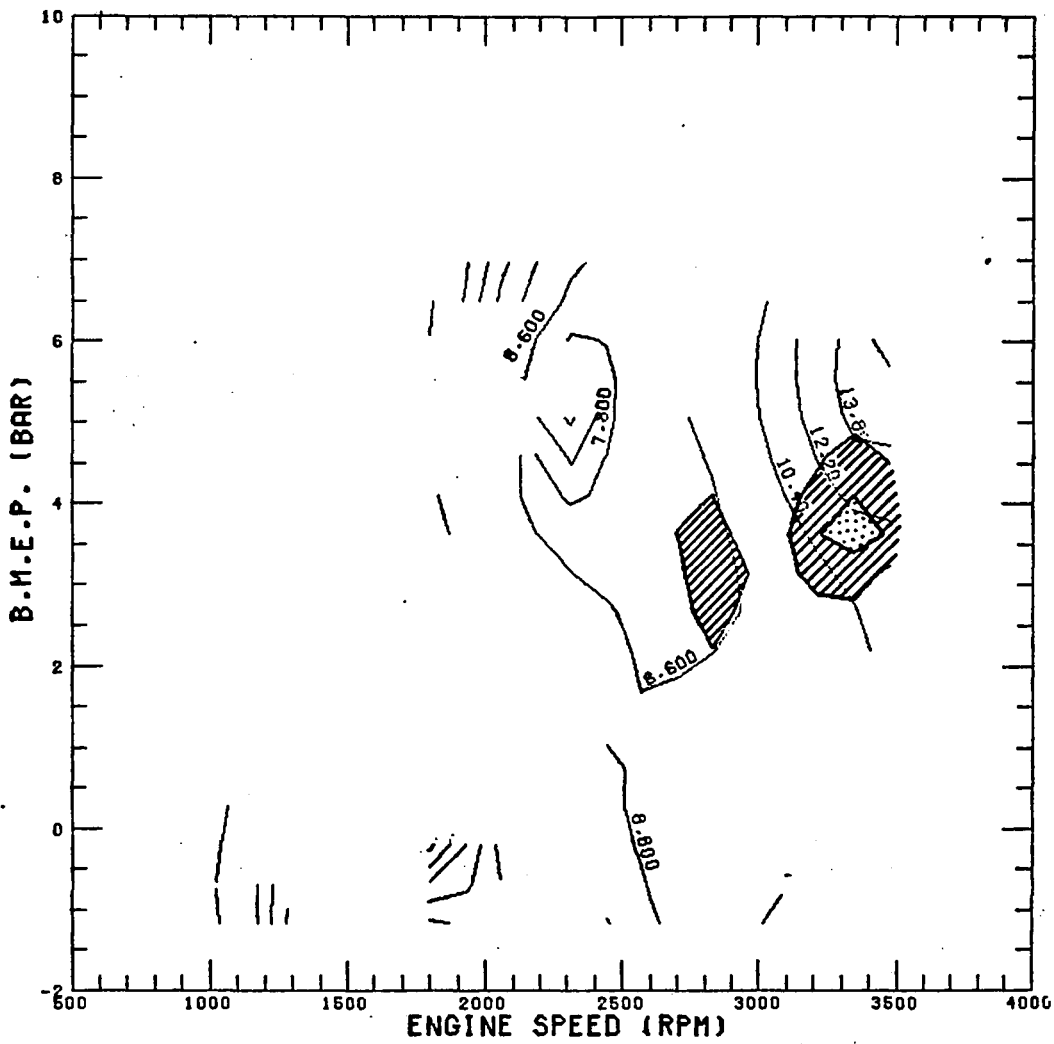

50 HP N.A. 90 CID

CO - EMISSION (G/H)

764.0 SEC HIGHWAY TEST DATE 07/10/76 14.30.52

TEST RESULT 8.22 G/ 10.25 MI = 0.80 G/MI

SHADED REGIONS 4.02 0.93 G

VEHICLE 1020 KG MASS, 0.80 SQM CW*F, 1.75 % ROLLING DRAG
TRANSMISSION AXLE/GEAR COMBINATION NO. 3

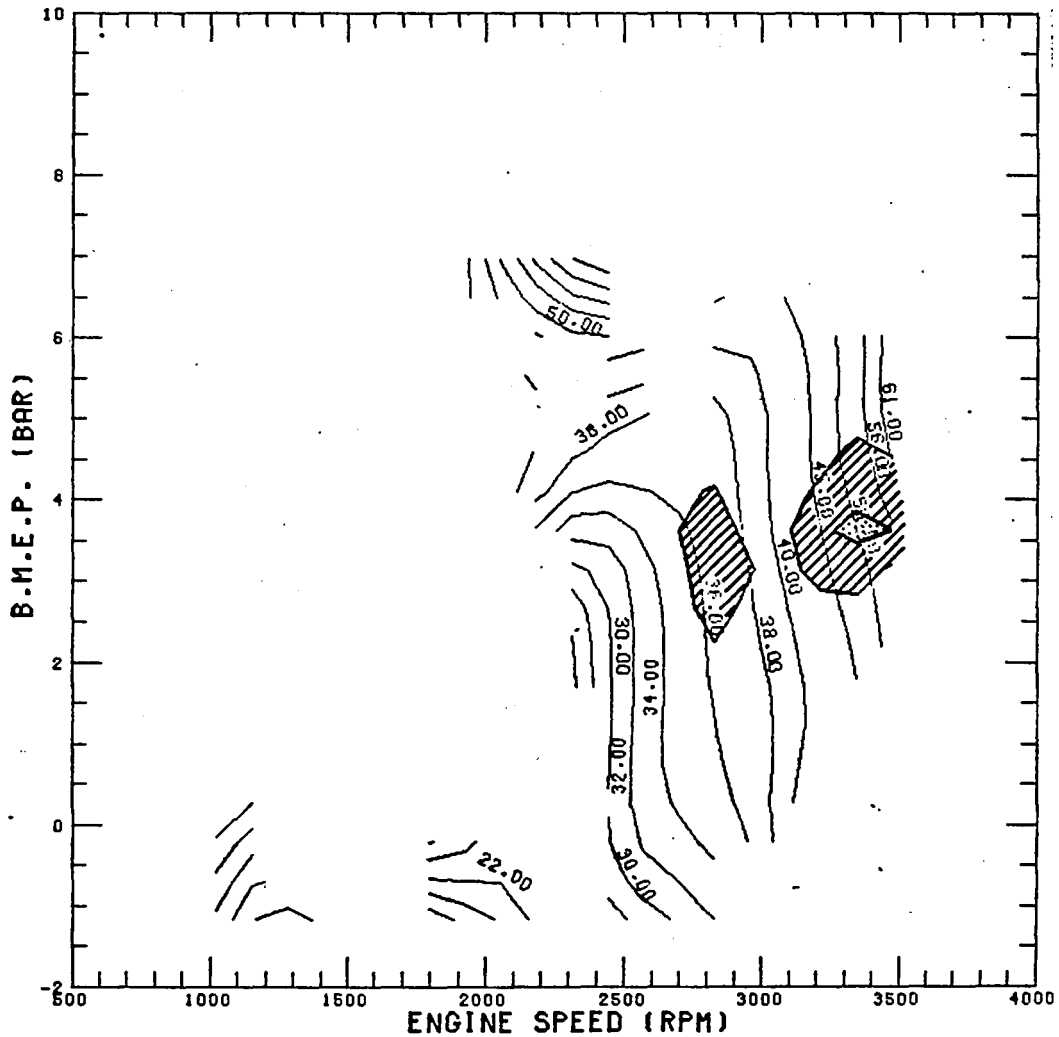

50 HP N.A. 90 CID

NOX - EMISSION (G/H)

764.0 SEC HIGHWAY TEST DATE 07/10/76 14.30.52

TEST RESULT 7.97 G/ 10.25 MI = 0.78 G/MI

SHADED REGIONS 3.99 0.52 G

VEHICLE 1020 KG MASS. 0.80 SQM CW/F. 1.75 % ROLLING DRAG
TRANSMISSION AXLE/GEAR COMBINATION NO. 3

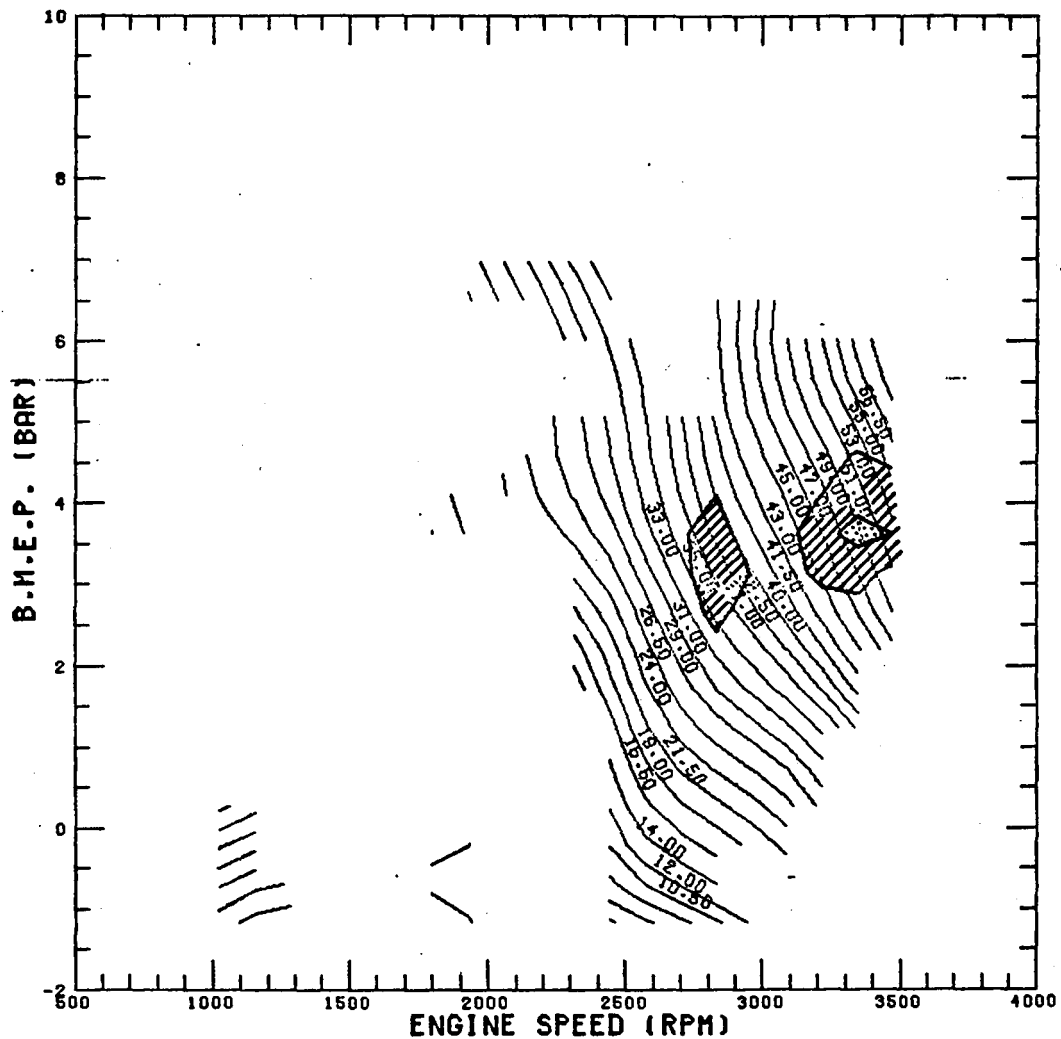

50 HP N.A. E.G.R.

FUEL CONSUMPTION (KG/H)

1372.0 SEC US-CITY TEST DATE 11/08/77 14.21.28

TEST RESULT 562.51 G/ 7.45 MI = 41.45 MPG

SHADED REGIONS 282.20 47.57 M

VEHICLE 1020 KG MASS, 0.80 SQM CWRF, 1.75 % ROLLING DRAG
TRANSMISSION AXLE/GEAR COMBINATION NO. 3

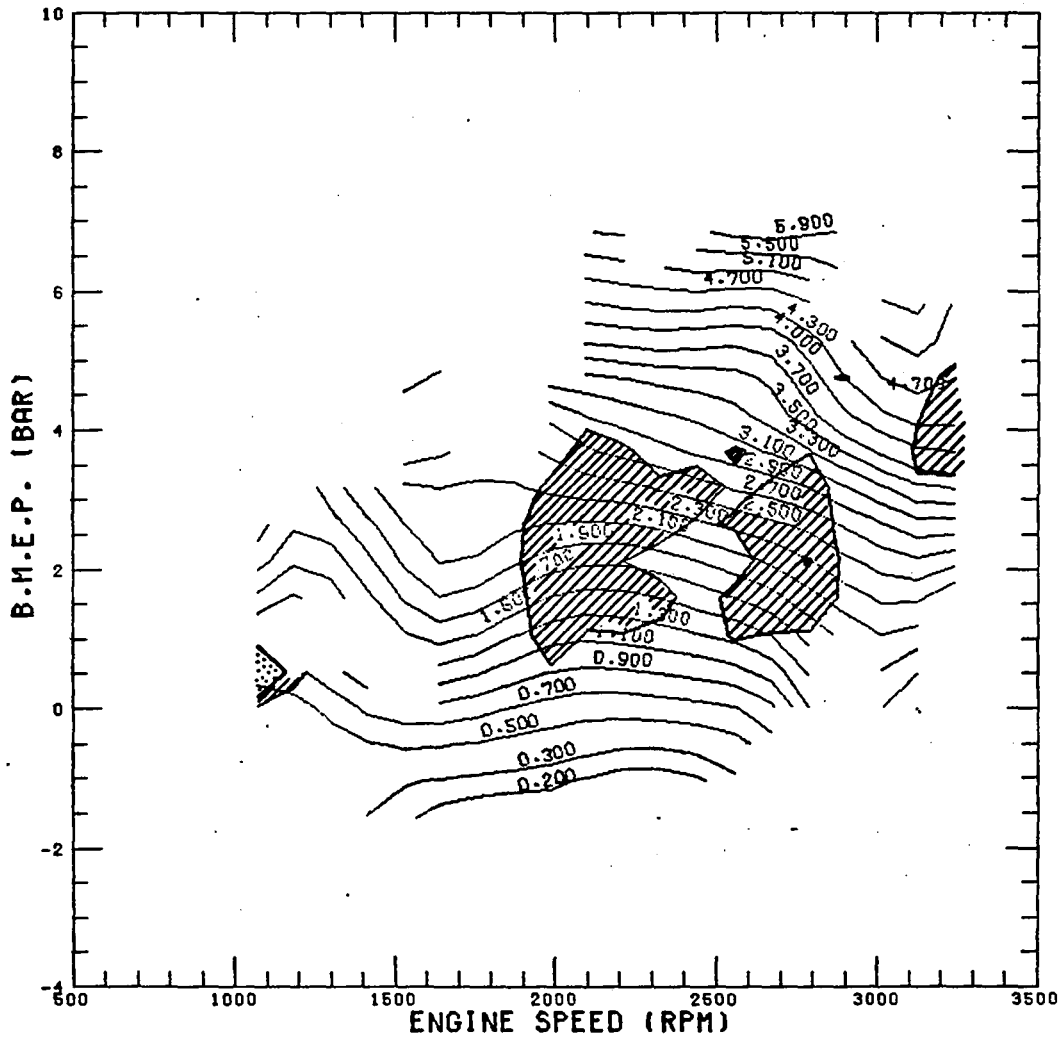

50 HP N.A. E.G.R.

AIR TO FUEL RATIO

1372.0 SEC US-CITY TEST DATE 11/08/77 14.21.28

TEST RESULT 1372.25 S/ 7.45 MI = 19.54 MPH

SHADED REGIONS 678.62 276.00 M

VEHICLE 1020 KG MASS. 0.80 SQM CM*F. 1.75 % ROLLING DRAG

TRANSMISSION AXLE/GEAR COMBINATION NO. 3

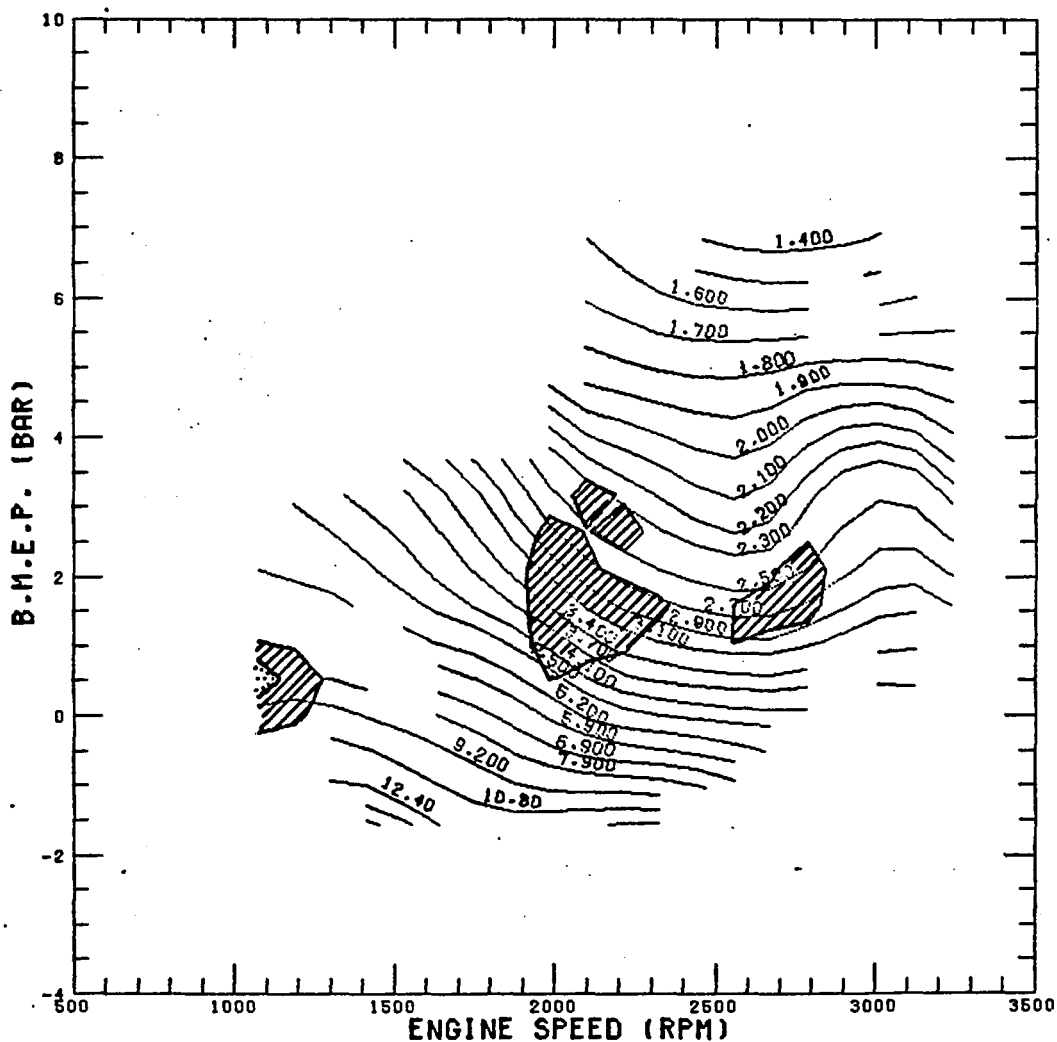

50 HP N.A. E.G.R.

HC - EMISSION (G/H)

1372.0 SEC US-CITY TEST DATE 11/08/77 14.21.28

TEST RESULT 2.29 G/ 7.45 MI = 0.31 G/MI

SHADED REGIONS 1.15 0.22 G

VEHICLE 1020 KG MASS. 0.80 SQM CW*F. 1.75 % ROLLING DRAG
TRANSMISSION AXLE/GEAR COMBINATION NO. 3

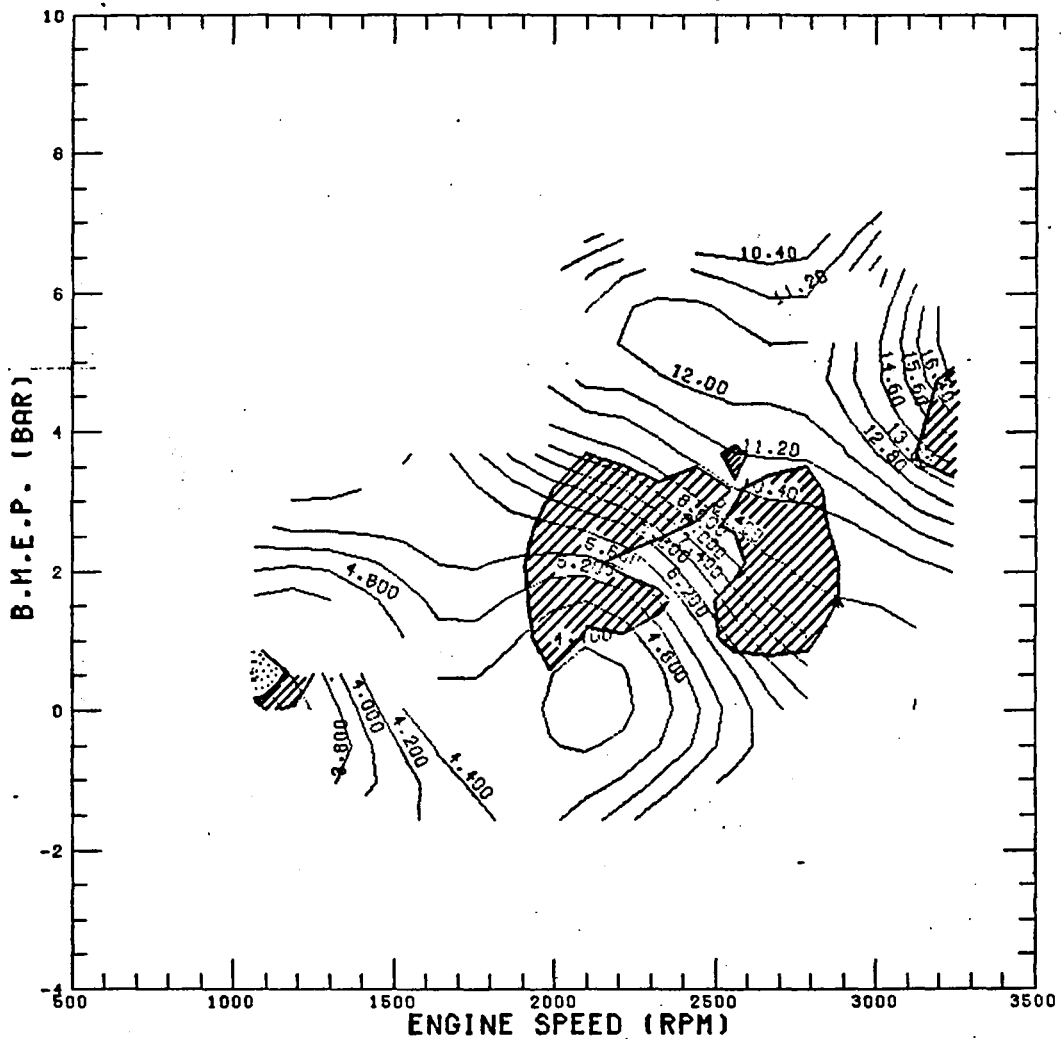

50 HP N.A. E.G.R.

CO - EMISSION (G/H)

1372.0 SEC US-CITY TEST DATE 11/08/77 14.21.28

TEST RESULT 13.76 G/ 7.45 MI = 1.85 G/MI

SHADED REGIONS 6.91 1.19 G

VEHICLE 1020 KG MASS, 0.80 SQM CW=F, 1.75 % ROLLING DRAG
TRANSMISSION AXLE/GEAR COMBINATION NO. 3

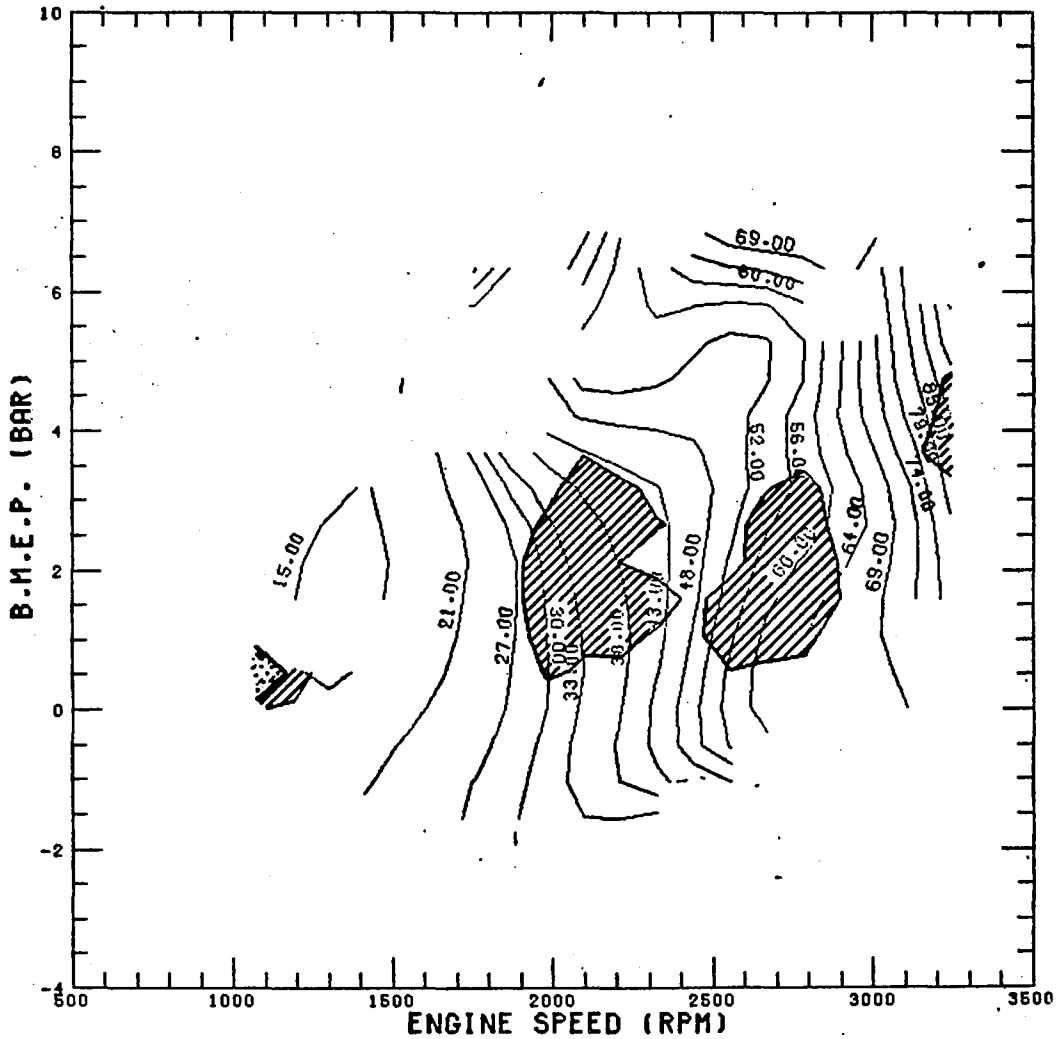

50 HP N.A. E.G.R.

NOX - EMISSION (G/H)

1372.0 SEC US-CITY TEST DATE 11/08/77 14.21.28

TEST RESULT 4.15 G/ 7.45 MI = 0.56 G/MI

SHADED REGIONS 2.06 0.50 G

VEHICLE 1020 KG MASS. 0.80 SQM CWRF. 1.75 % ROLLING DRAG
TRANSMISSION AXLE/GEAR COMBINATION NO. 3

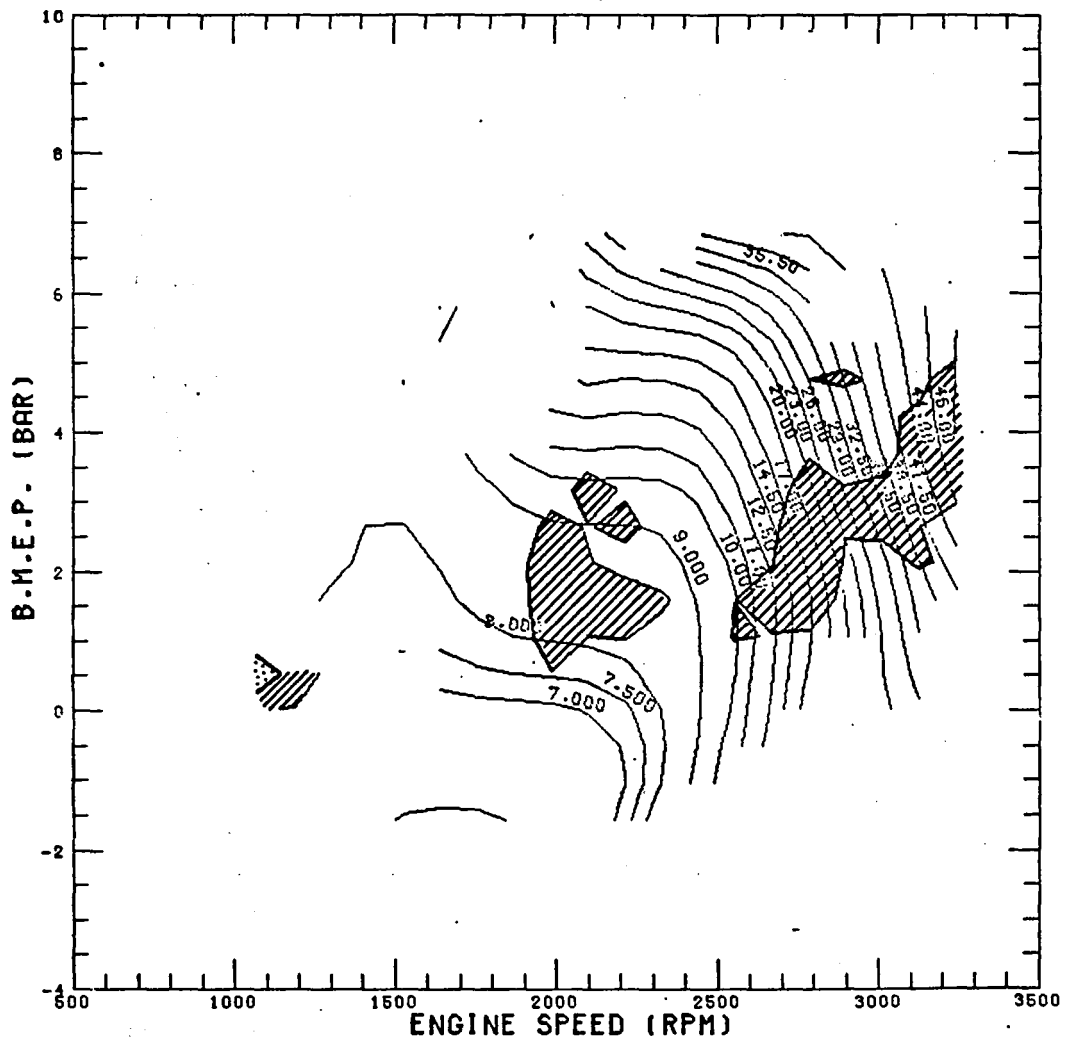

50 HP N.A. E.G.R.

FUEL CONSUMPTION (KG/H)

764.0 SEC HIGHWAY TEST DATE 11/08/77 '14.50.33

TEST RESULT 765.71 G/ 10.25 MI = 41.90 MPG

SHADED REGIONS 384.92 50.38 M

VEHICLE 1020 KG MASS. 0.80 SQM CW*F. 1.75 % ROLLING DRAG
TRANSMISSION AXLE/GEAR COMBINATION NO. 3

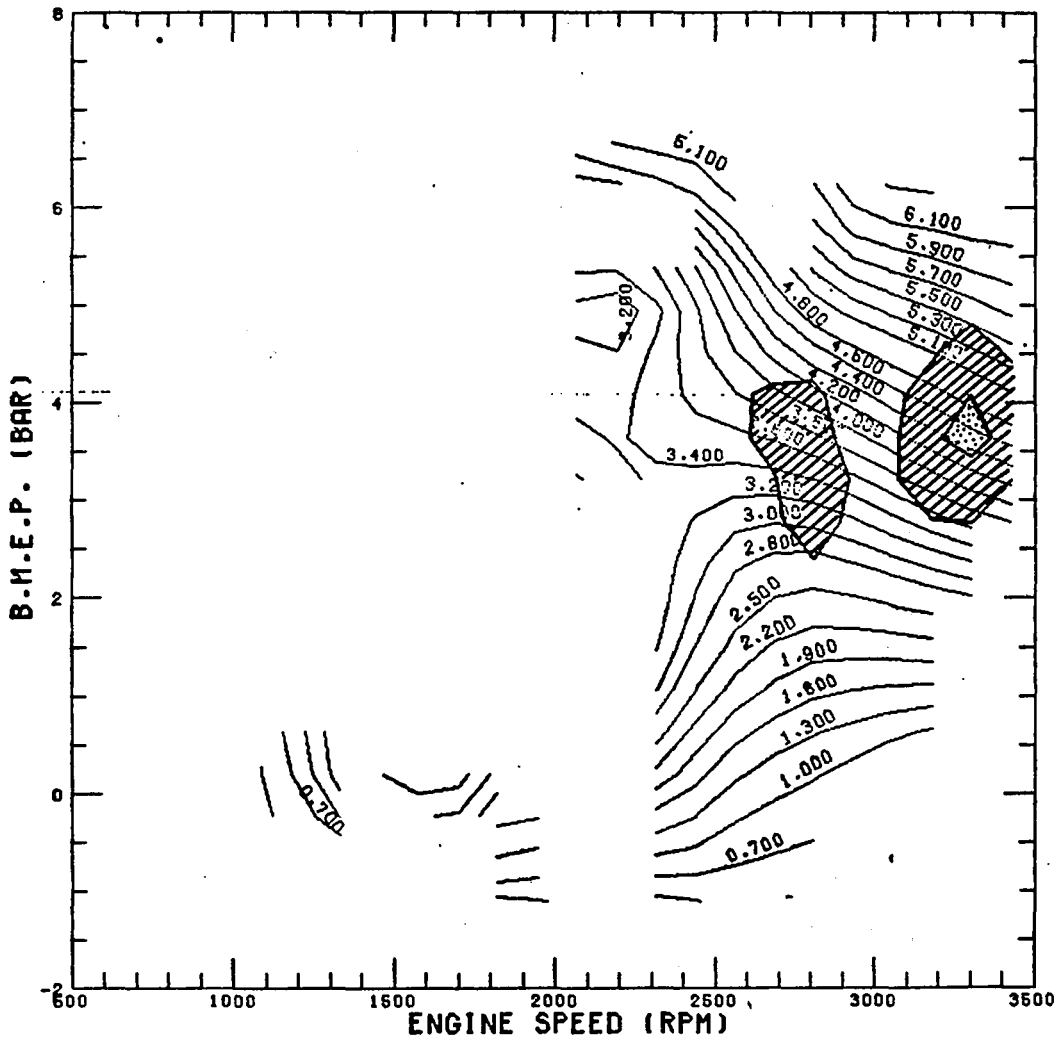

50 HP N.A. E.G.R.

AIR TO FUEL RATIO

764.0 SEC HIGHWAY TEST DATE 11/08/77 14.50.33

TEST RESULT 764.25 S/ 10.25 MI = 48.28 MPH

SHADED REGIONS 384.62 99.37 M

VEHICLE 1020 KG MASS. 0.80 SQM CW*F. 1.75 % ROLLING DRAG
TRANSMISSION AXLE/GEAR COMBINATION NO. 3

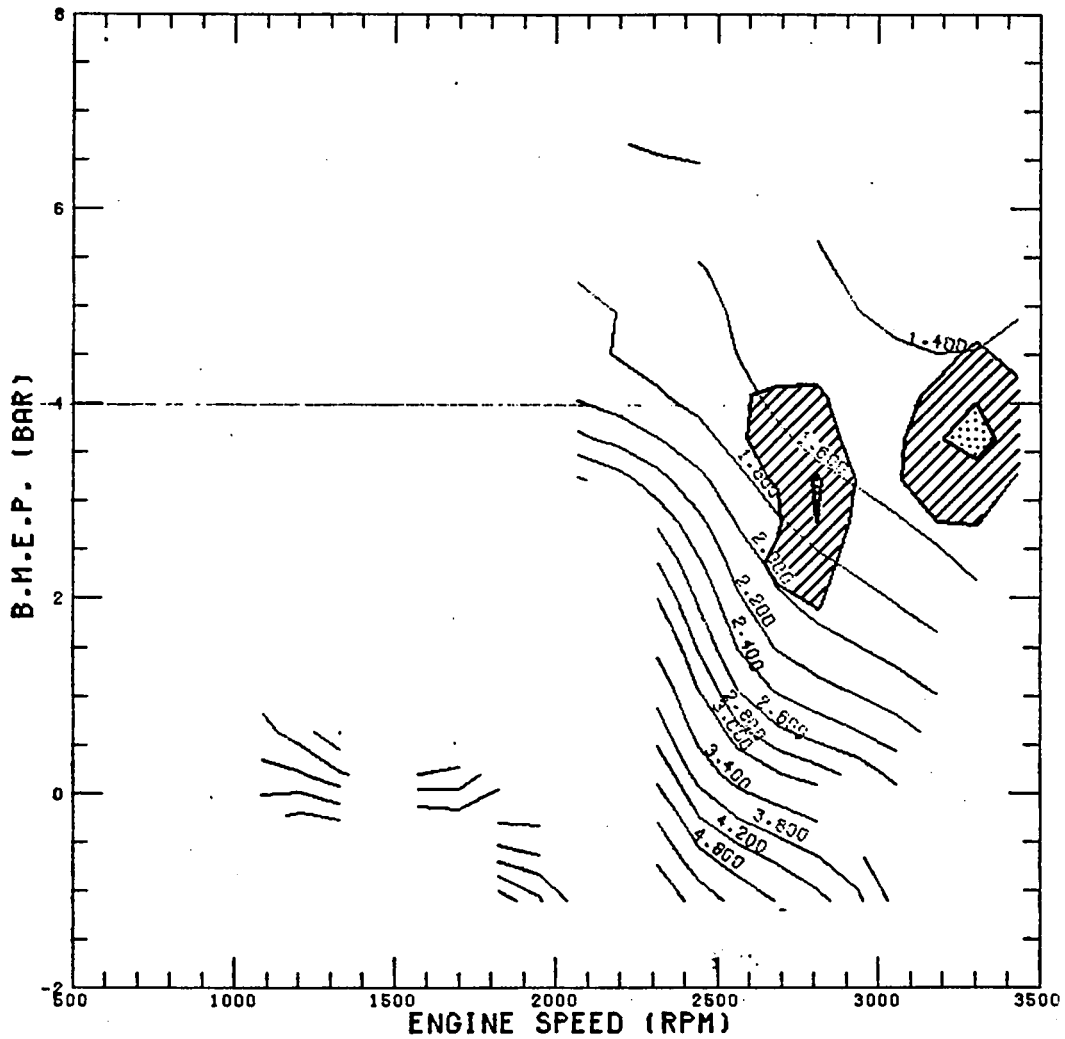

50 HP N.A. E.G.R.

HC - EMISSION (G/H)

764.0 SEC HIGHWAY TEST DATE 11/08/77 14.50.33

TEST RESULT 5.86 G/ 10.25 MI = 0.57 G/MI

SHADED REGIONS 2.84 0.49 G

VEHICLE 1020 KG MASS. 0.80 SQM CW*F. 1.75 % ROLLING DRAG
TRANSMISSION AXLE/GEAR COMBINATION NO. 3

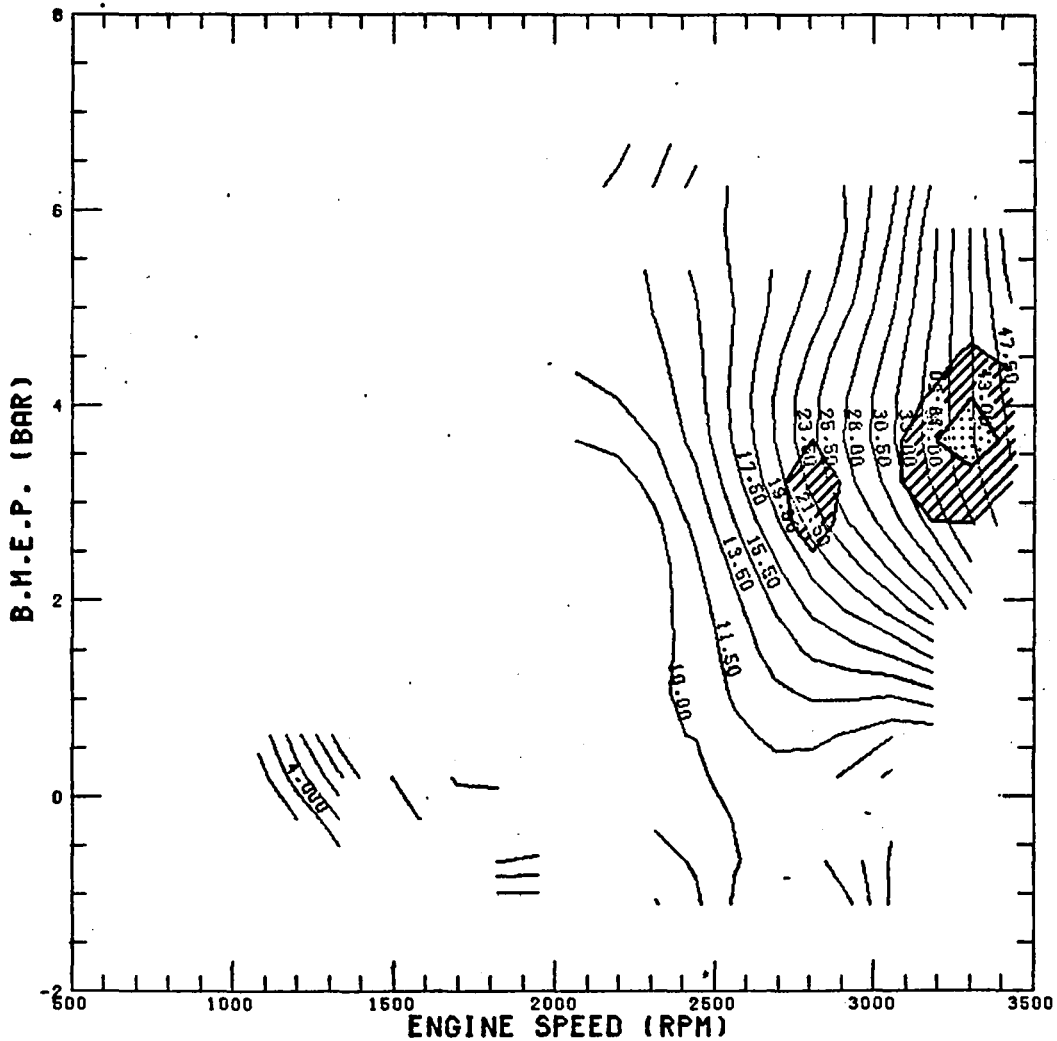

50 HP N.A. E.G.R.

CO - EMISSION (G/H)

764.0 SEC HIGHWAY TEST DATE 11/08/77 14.50.33

TEST RESULT 25.24 G/ 10.25 MI = 2.46 G/MI

SHADED REGIONS 12.52 1.89 G

VEHICLE 1020 KG MASS. 0.80 SQM CW*F. 1.75 % ROLLING DRAG
TRANSMISSION AXLE/GEAR COMBINATION NO. 3

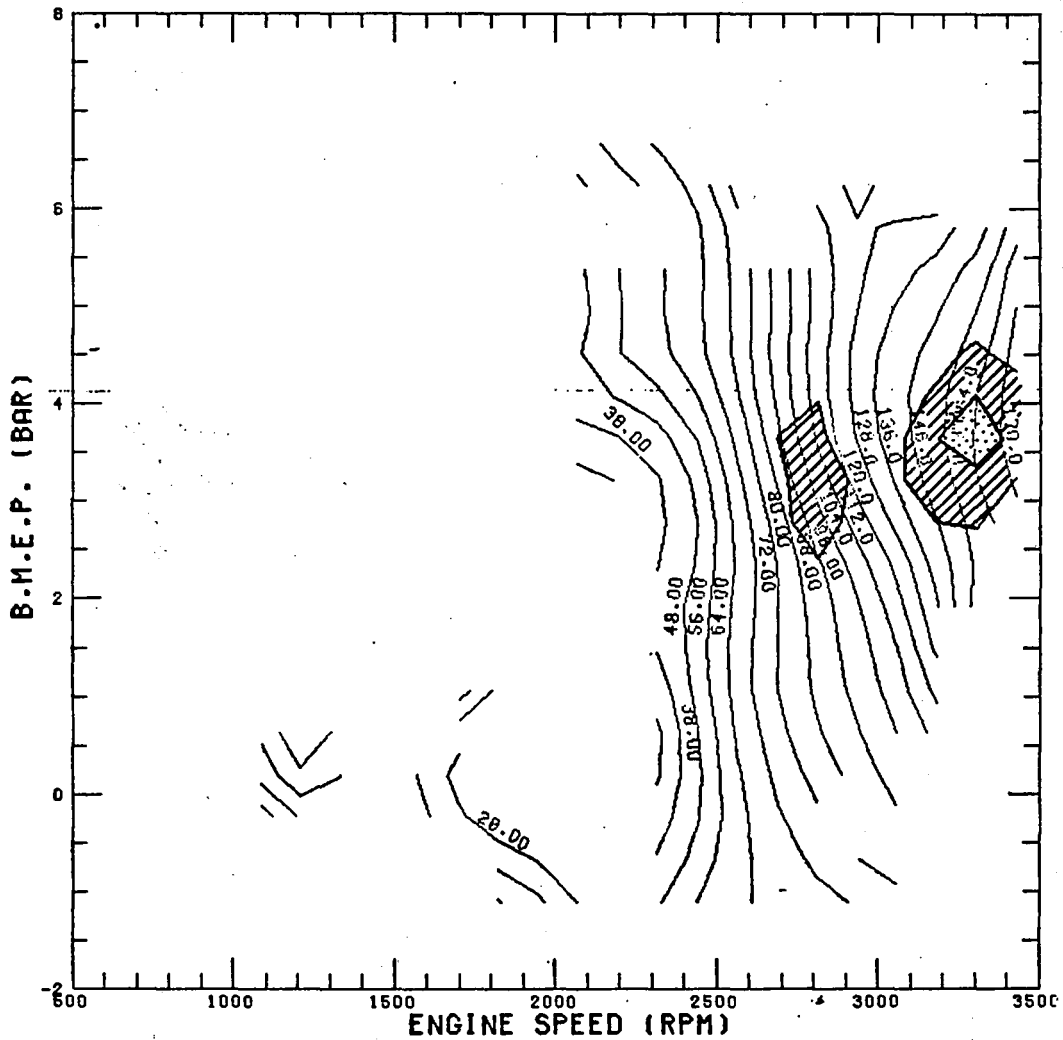

50 HP N.A. E.G.R.

NOX - EMISSION (G/H)

764.0 SEC HIGHWAY TEST DATE 11/08/77 14.50.33

TEST RESULT 3.53 G/ 10.25 MI = 0.34 G/MI

SHADED REGIONS 1.76 0.39 G

VEHICLE 1020 KG MASS, 0.80 SQM CW*F, 1.75 % ROLLING DRAG
TRANSMISSION AXLE/GEAR COMBINATION NO. 3

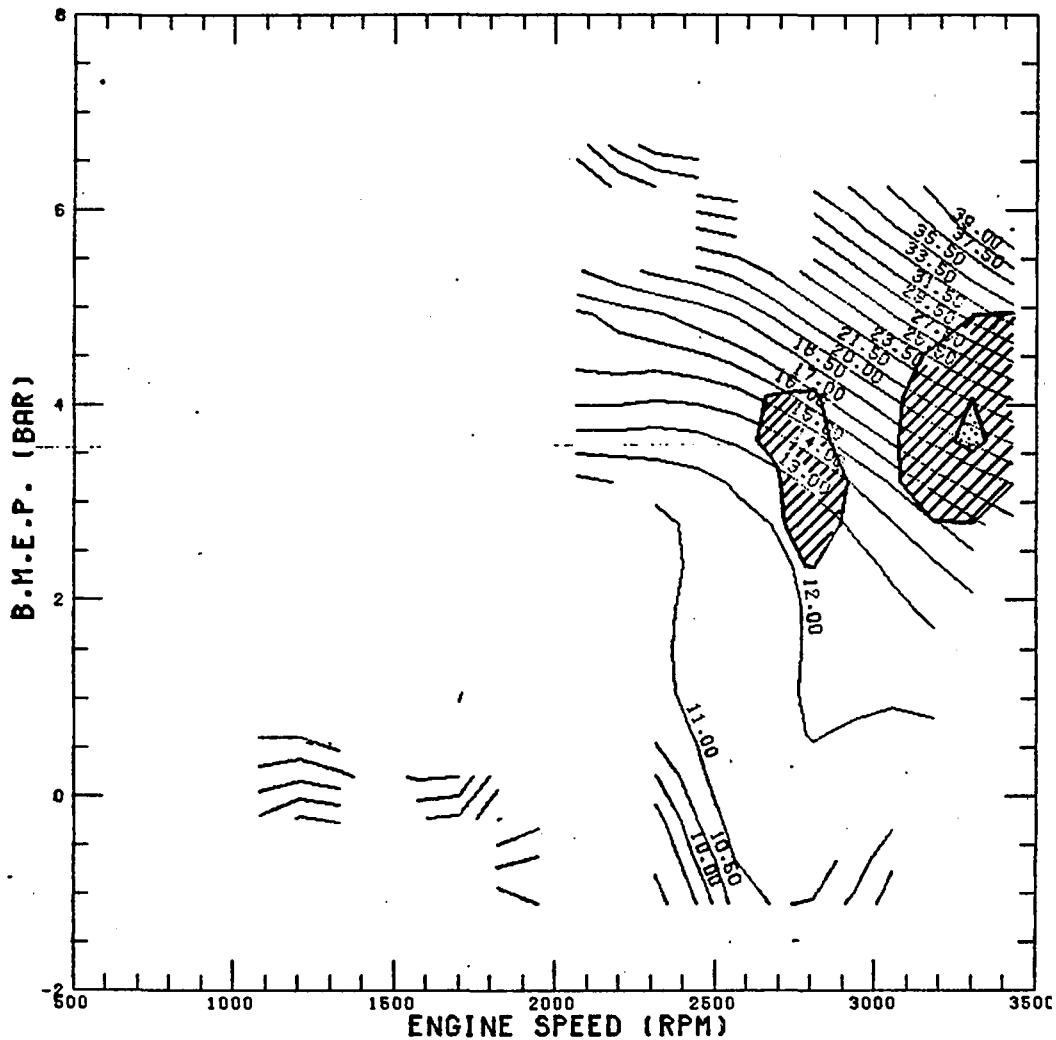

70 HP TC 90 CID

FUEL CONSUMPTION (KG/H)

1372.0 SEC US-CITY TEST DATE 10/11/76 11.34.59

TEST RESULT 529.61 G/ 7.45 MI = 43.92 MPG

SHADED REGIONS 267.07 60.38 M

VEHICLE 1020 KG MASS. 0.80 SQM CMF. 1.75 % ROLLING DRAG
TRANSMISSION AXLE/GEAR COMBINATION NO. 8

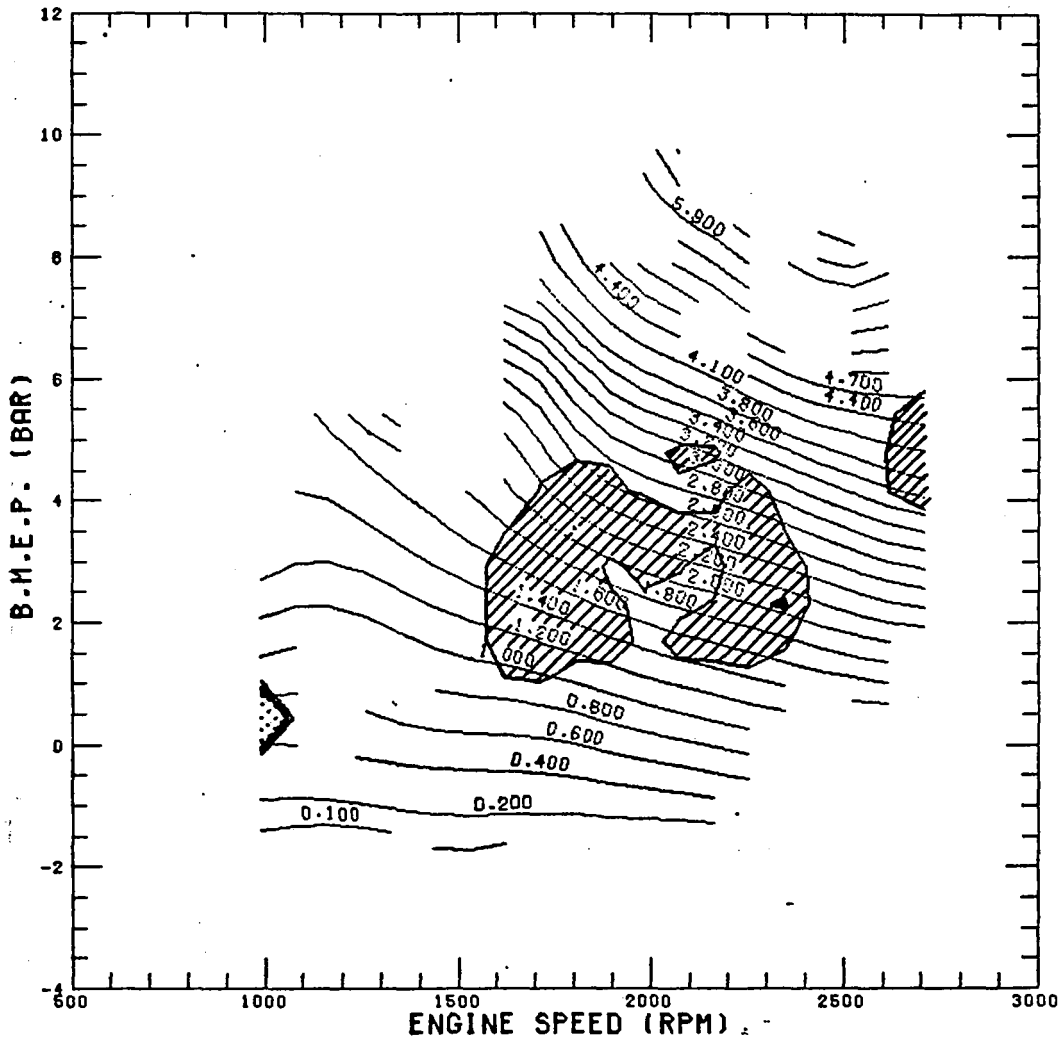

70 HP TC 90 CID

AIR TO FUEL RATIO

1372.0 SEC US-CITY TEST DATE 10/11/76 11.34.59

TEST RESULT 1372.25 S/ 7.45 MI = 19.54 MPH

SHADED REGIONS 679.50 281.75 M

VEHICLE 1020 KG MASS, 0.80 SOM CM*F, 1.75 % ROLLING DRAG
TRANSMISSION AXLE/GEAR COMBINATION NO. 8

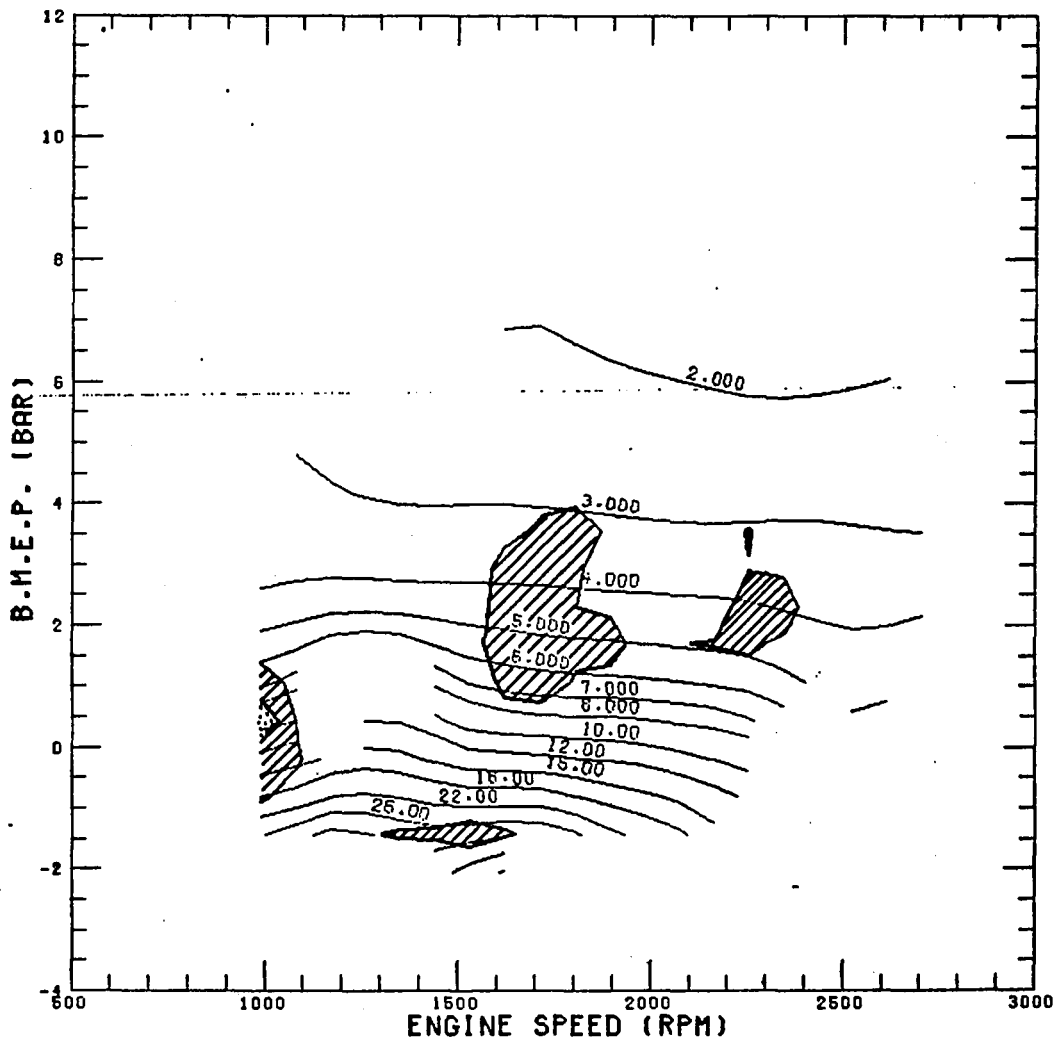

70 HP TC 90 CID

HC - EMISSION (G/H)

1372.0 SEC US-CITY TEST DATE 10/11/76 11.34.59

TEST RESULT 1.70 G/ 7.45 MI = 0.23 G/MI

SHADED REGIONS 0.84 0.28 G

VEHICLE 1020 KG MASS, 0.80 SQM CW*F, 1.75 % ROLLING DRAG
TRANSMISSION AXLE/GEAR COMBINATION NO. 8

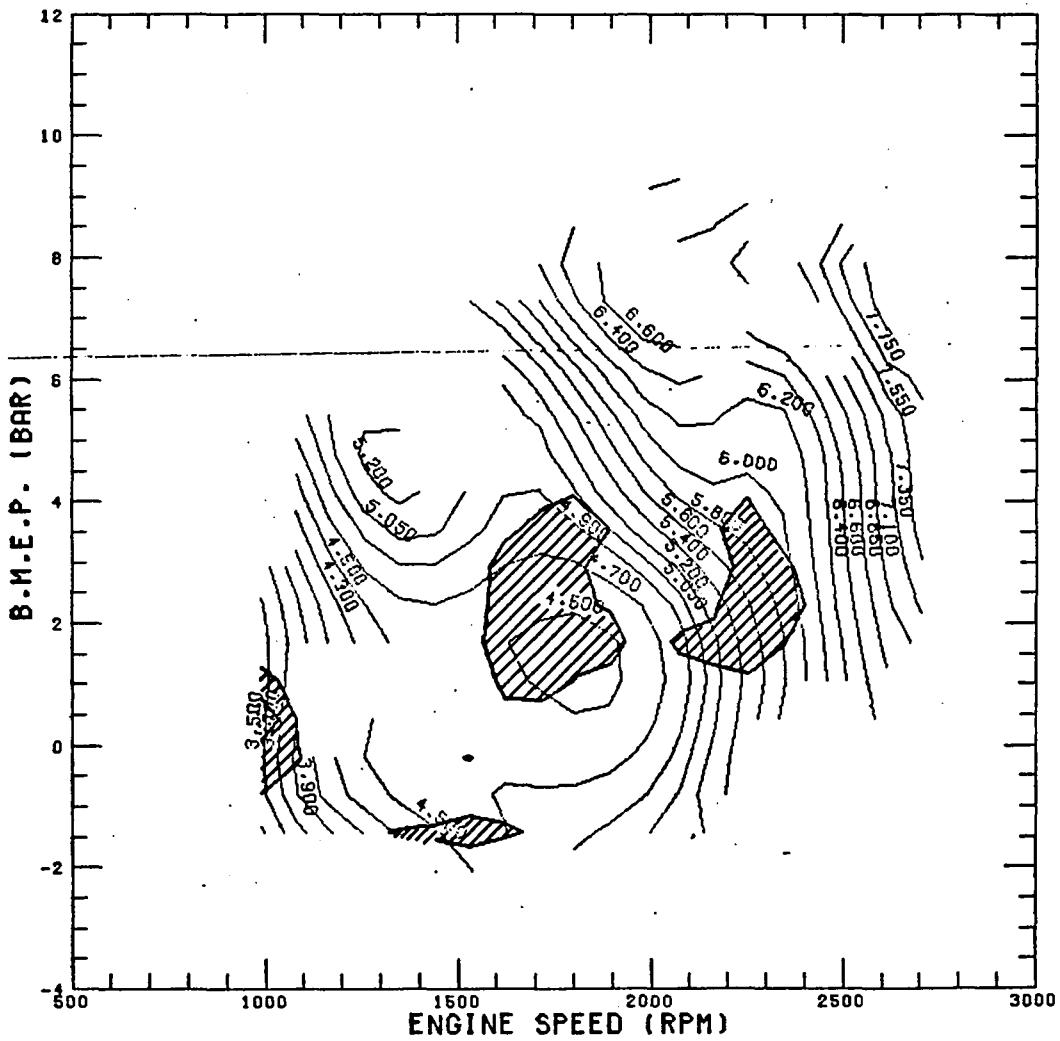

70 HP TC 90 CID

CO - EMISSION (G/H)

1372.0 SEC US-CITY TEST DATE 10/11/76. 11.34.59

TEST RESULT 5.39 G/ 7.45 MI = 0.72 G/MI

SHADED REGIONS 2.68 0.93 G

VEHICLE 1020 KG MASS. 0.80 SQM CM²F. 1.75 % ROLLING DRAG
TRANSMISSION AXLE/GEAR COMBINATION NO. 8

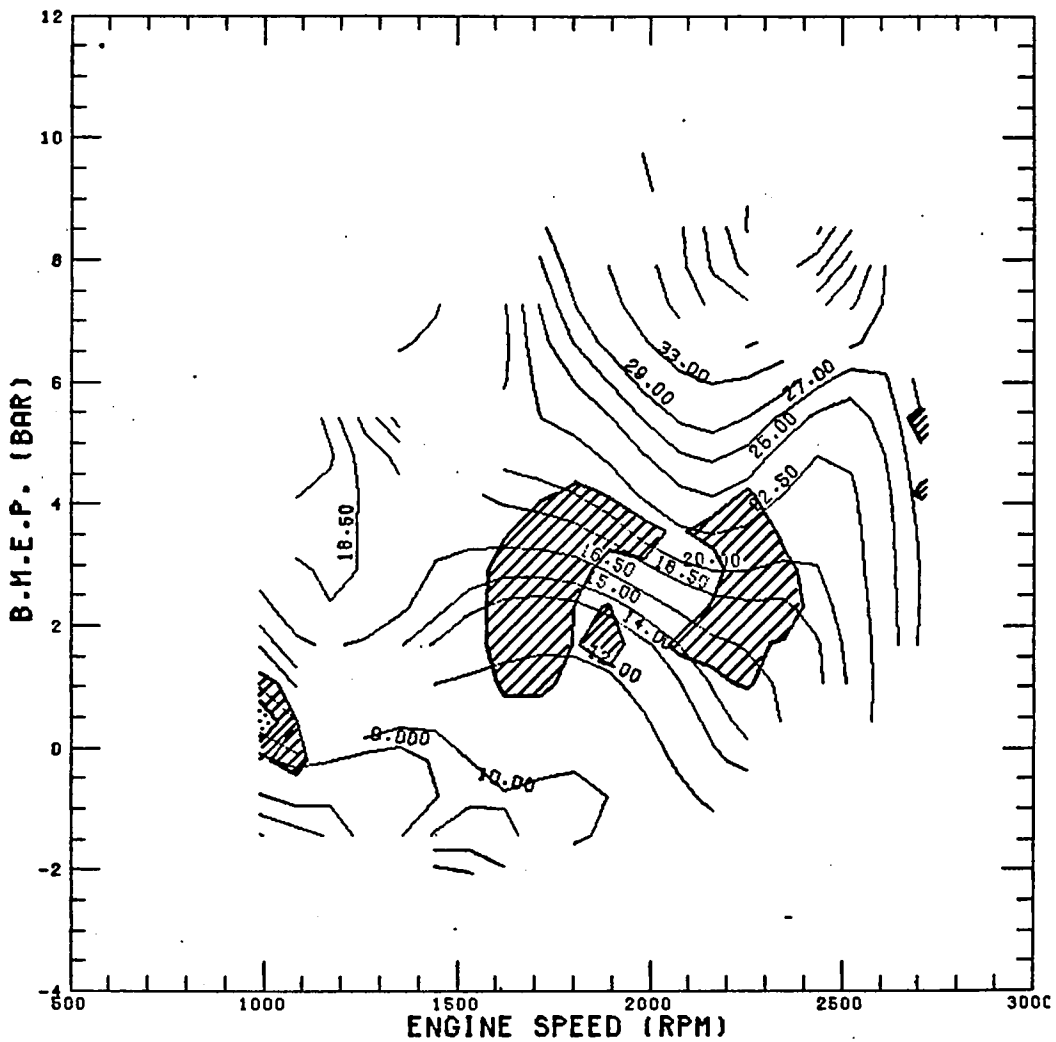

70 HP TC 90 CID

NOX - EMISSION (G/H)

1372.0 SEC US-CITY TEST DATE 10/11/76 11.34.59

TEST RESULT 6.00 G/ 7.45 MI = 0.80 G/MI

SHADED REGIONS 2.96 0.61 G

VEHICLE 1020 KG MASS, 0.80 SOM CW*F, 1.75 % ROLLING DRAG
TRANSMISSION AXLE/GEAR COMBINATION NO. 8

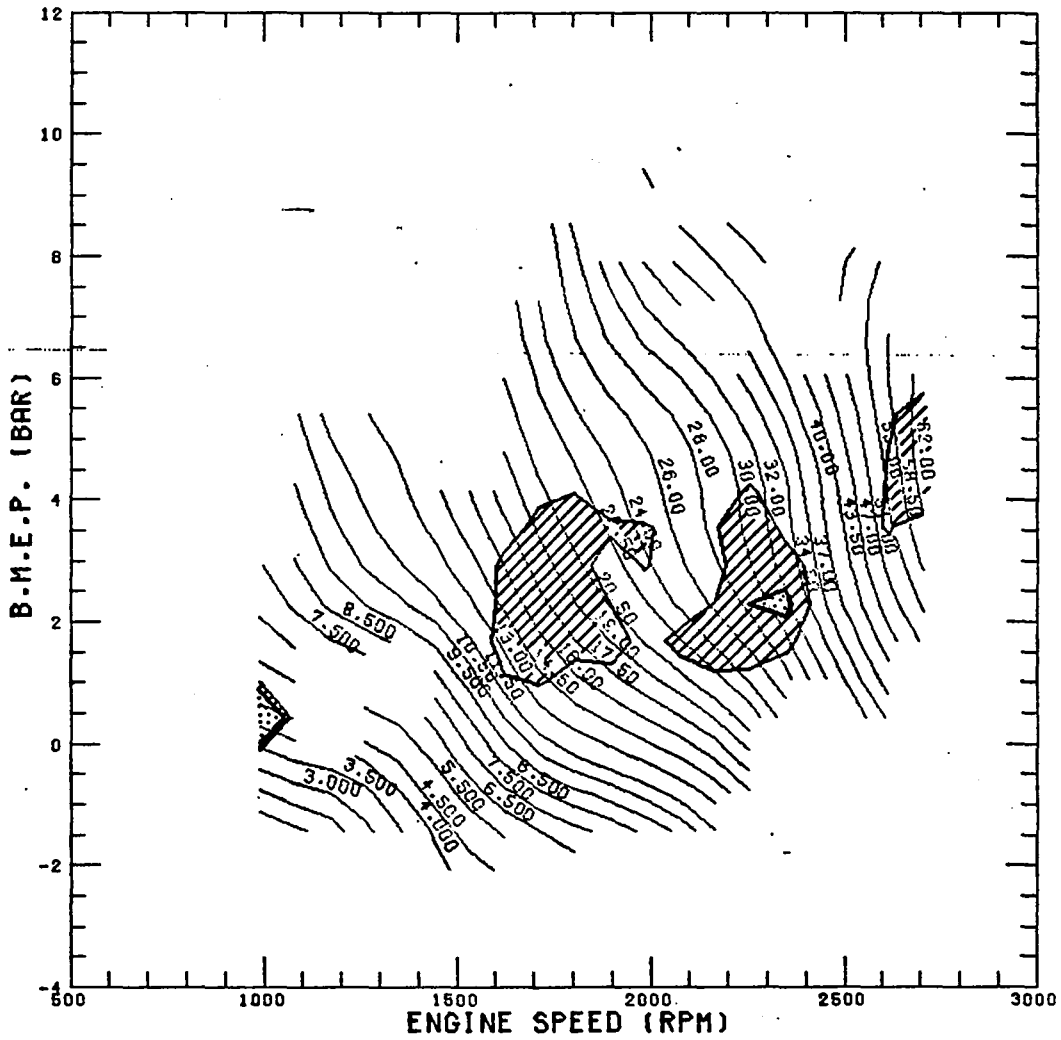

70 HP TC 90 CID

FUEL CONSUMPTION (KG/H)

764.0 SEC HIGHWAY TEST DATE 10/11/76 13-03-54

TEST RESULT 688.17 G/ 10.25 MI = 46.51 MPG

SHADED REGIONS 336.02 72.69 M

VEHICLE 1020 KG MASS. 0.80 SDM CW*F. 1.75 % ROLLING DRAG
TRANSMISSION AXLE/GEAR COMBINATION NO. 8

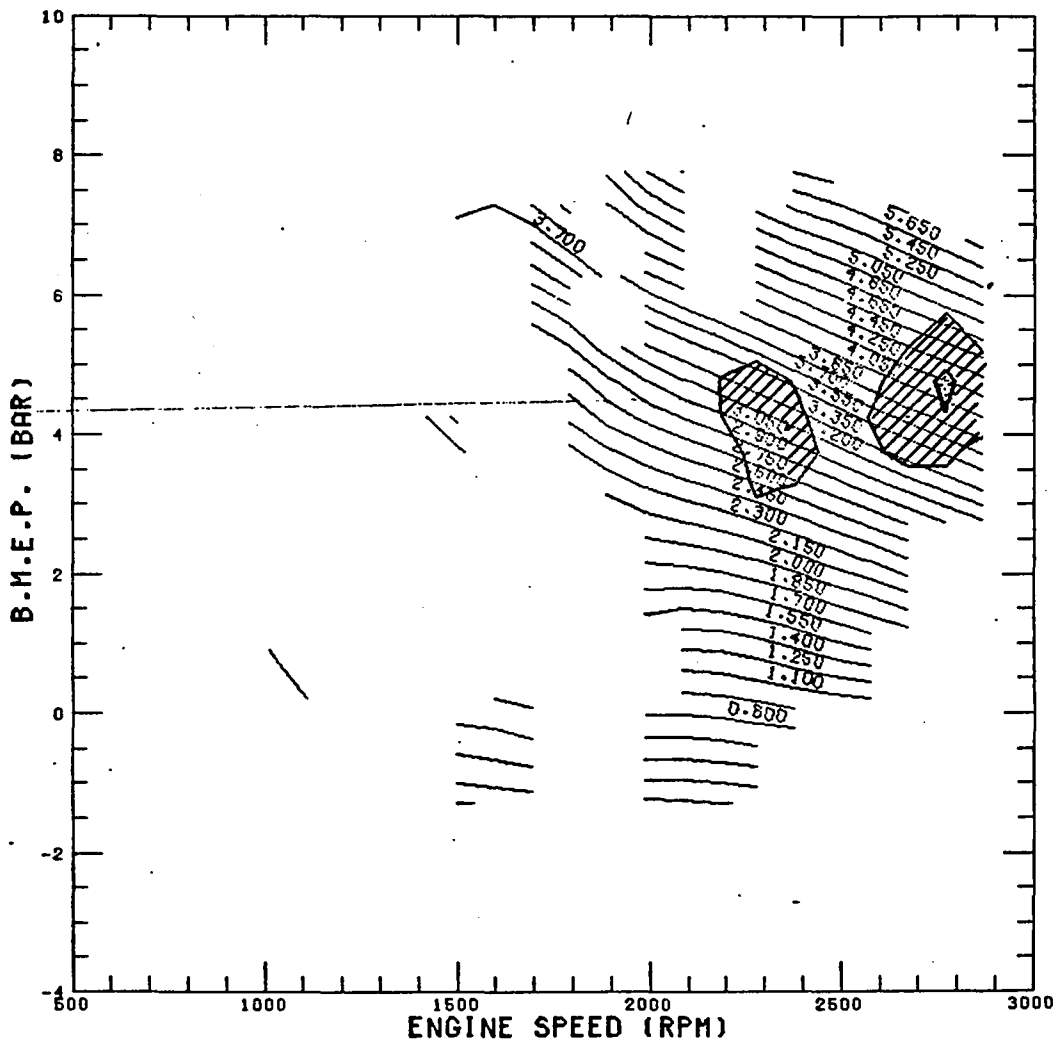

70 HP TC 90 CID

AIR TO FUEL RATIO

764.0 SEC HIGHWAY TEST DATE 10/11/76 .13-03.54

TEST RESULT 764.25 S/ 10.25 MI = 48.28 MPH

SHADED REGIONS 377-37 95.25 M

VEHICLE 1020 KG MASS, 0.80 SQM CW*F, 1.75 % ROLLING DRAG
TRANSMISSION AXLE/GEAR COMBINATION NO. 8

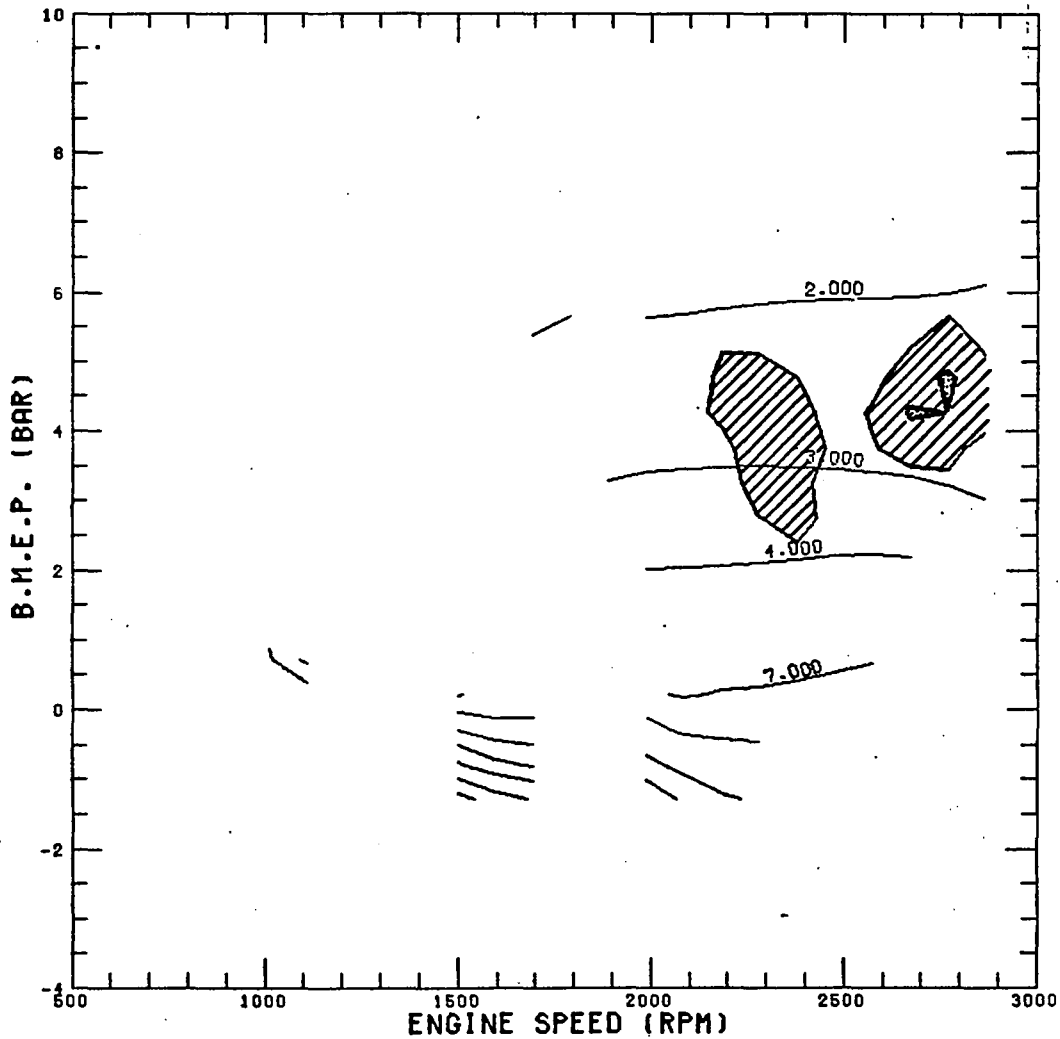

70 HP TC 90 CID

HC - EMISSION (G/H)

764.0 SEC HIGHWAY TEST DATE 10/11/76 13.03.54

TEST RESULT 0.83 G/ 10.25 MI = 0.08 G/MI

SHADED REGIONS 0.43 0.05 G

VEHICLE 1020 KG MASS. 0.80 SQM CW=F. 1.75 % ROLLING DRAG

TRANSMISSION AXLE/GEAR COMBINATION NO. 8

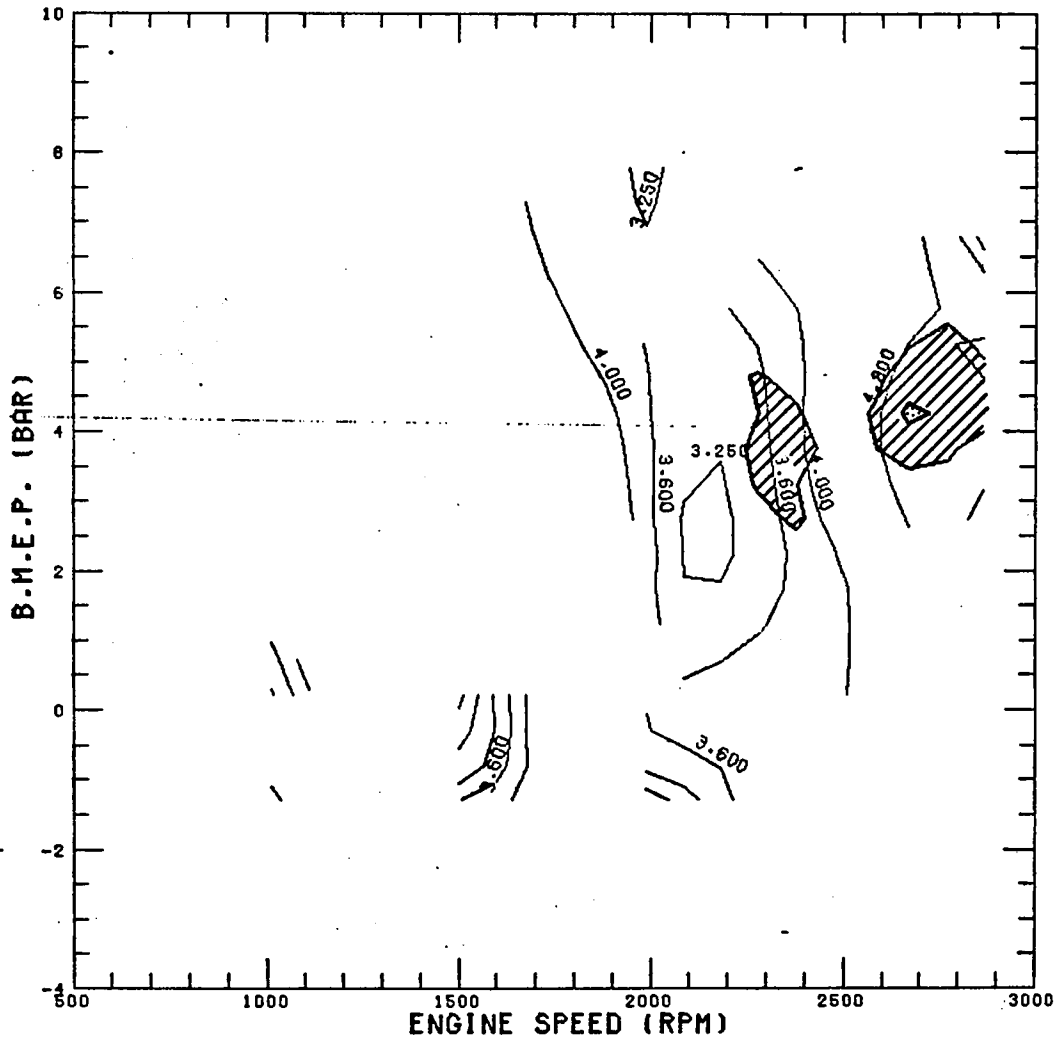

70 HP TC 90 CID

CO - EMISSION (G/H)

764.0 SEC HIGHWAY TEST DATE 10/11/76 13.03.54

TEST RESULT 4.16 G/ 10.25 MI = 0.41 G/MI

SHADED REGIONS 2.02 0.50 G

VEHICLE 1020 KG MASS. 0.80 SQM CW.F. 1.75 % ROLLING DRAG
TRANSMISSION AXLE/GEAR COMBINATION NO. 8

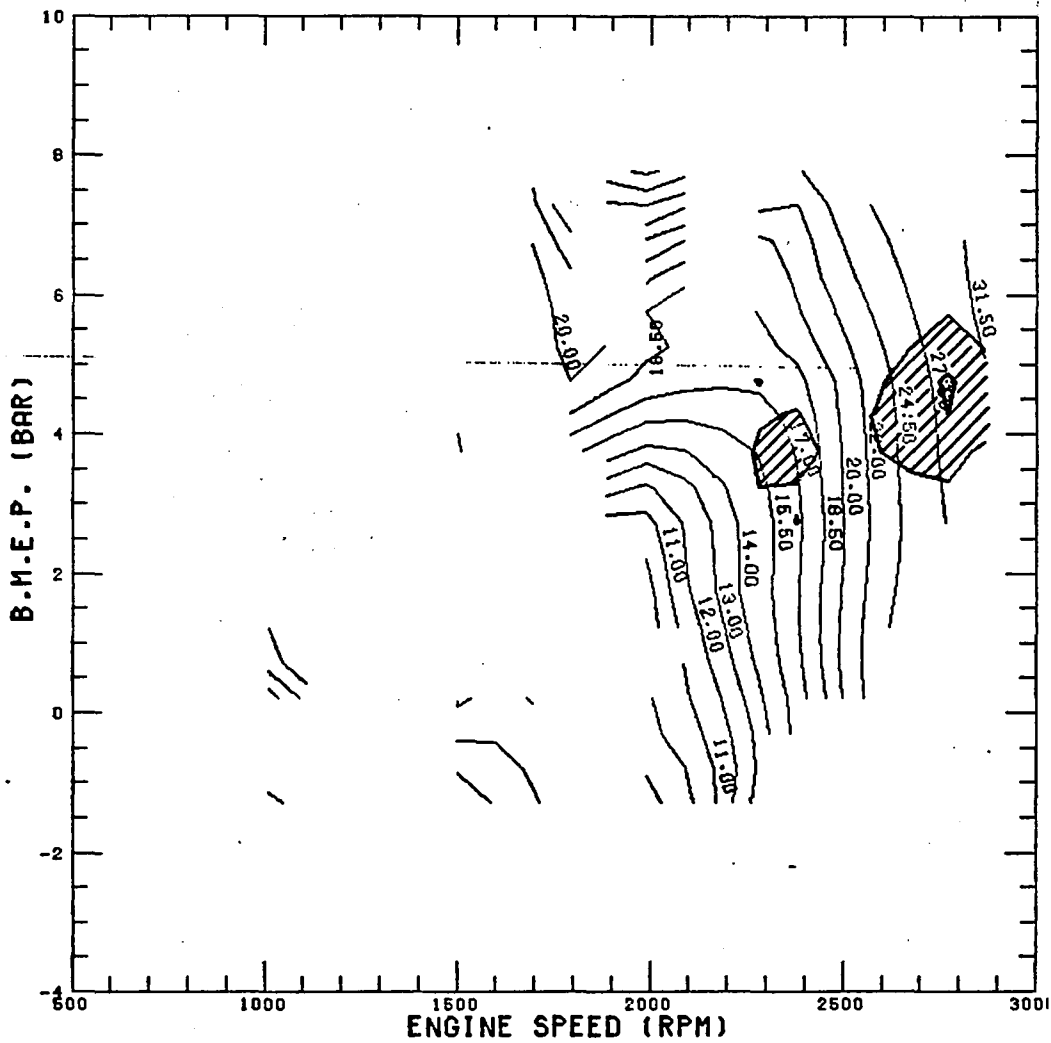

70 HP TC 90 CID

NOX - EMISSION (G/H)

764.0 SEC HIGHWAY TEST DATE 10/11/76 13.03.54

TEST RESULT 9.49 G/ 10.25 MI = 0.93 G/MI

SHADED REGIONS 4.70 0.62 G

VEHICLE 1020 KG MASS. 0.80 SQM CW*F. 1.75 % ROLLING DRAG
TRANSMISSION AXLE/GEAR COMBINATION NO. 8

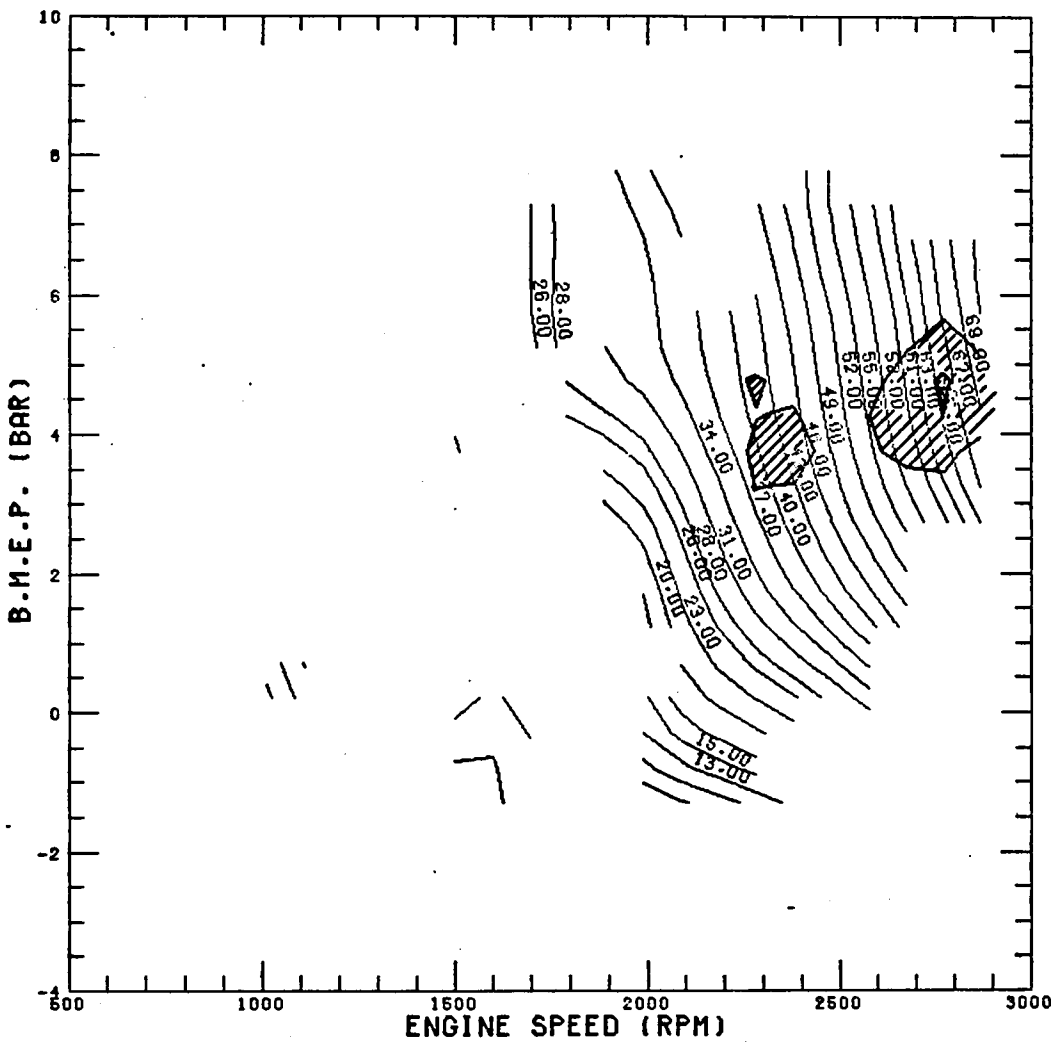

70 HP TC E.G.R.

FUEL CONSUMPTION (KG/H)

1372.0 SEC US-CITY TEST DATE 18/05/77 11.01.27

TEST RESULT 525.92 G/ 7.45 MI = 44.34 MPG

SHADED REGIONS 259.34 56.28 M

VEHICLE 1020 KG MASS. 0.80 SQM CM_wF. 1.75 % ROLLING DRAG

TRANSMISSION AXLE/GEAR COMBINATION NO. 8

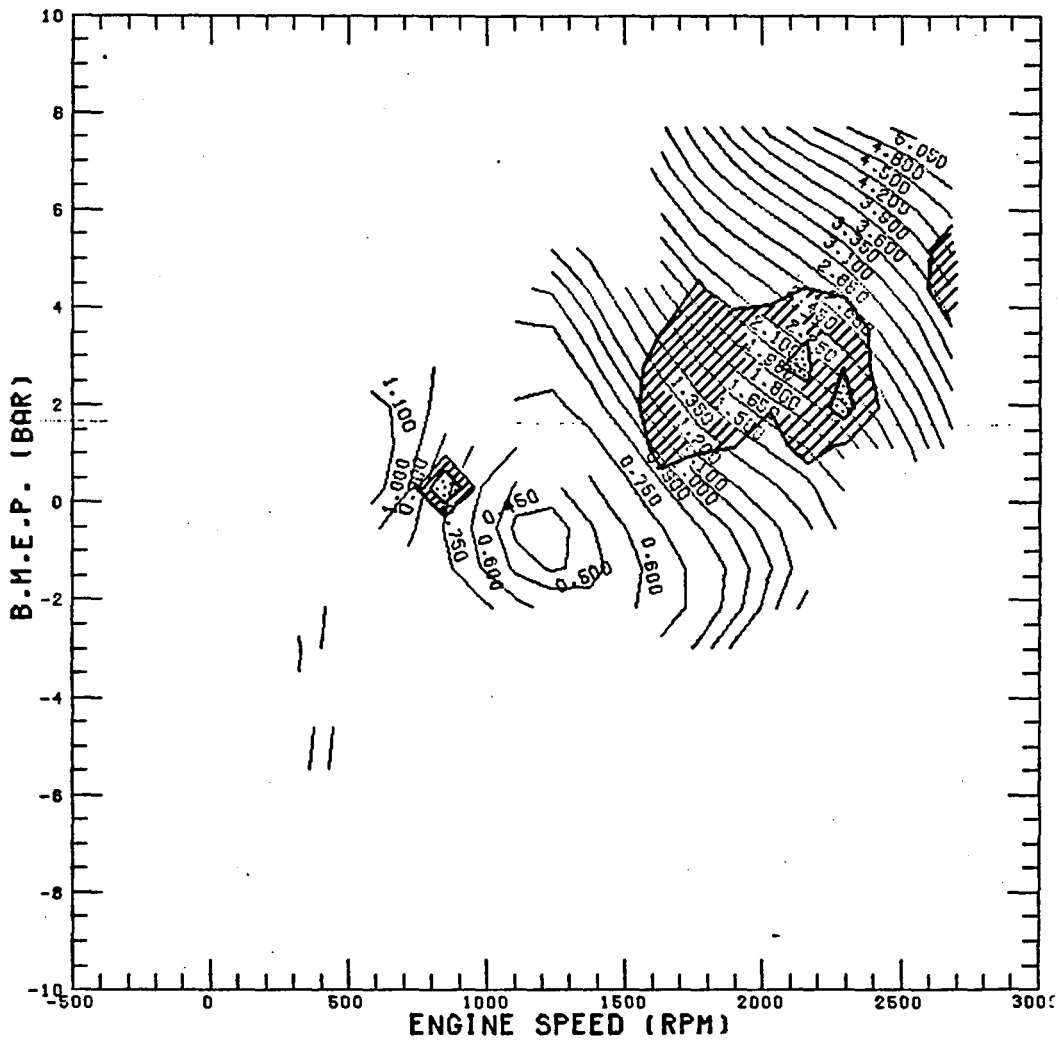

70 HP TC E.G.R.

AIR TO FUEL RATIO

1372.0 SEC US-CITY TEST DATE 18/05/77 11.01.27

TEST RESULT 1372.25 S/ 7.45 MI = 19.54 MPH

SHADED REGIONS 691.12 231.87 M

VEHICLE 1020 KG MASS. 0.80 SOM CW*F. 1.75 % ROLLING DRAG
TRANSMISSION AXLE/GEAR COMBINATION NO. 8

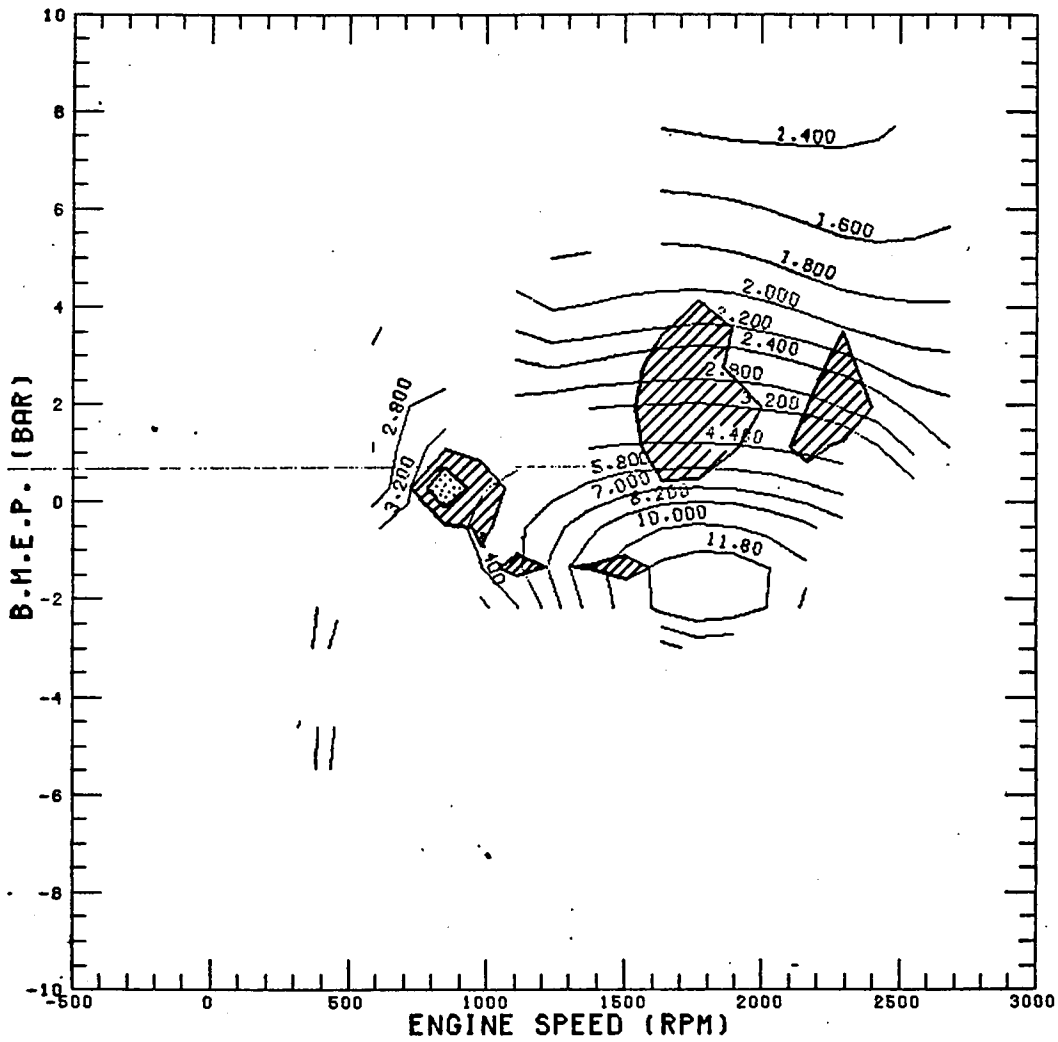

70 HP TC E.G.R.

HC - EMISSION (G/H)

1372.0 SEC US-CITY TEST DATE 18/05/77 11-01-27

TEST RESULT 2.21 G/ 7.45 MI = 0.30 G/MI

SHADED REGIONS 1.11 0-17 G

VEHICLE 1020 KG MASS. 0.80 SQM CHWF. 1.75 % ROLLING DRAG

TRANSMISSION AXLE/GEAR COMBINATION NO. 8

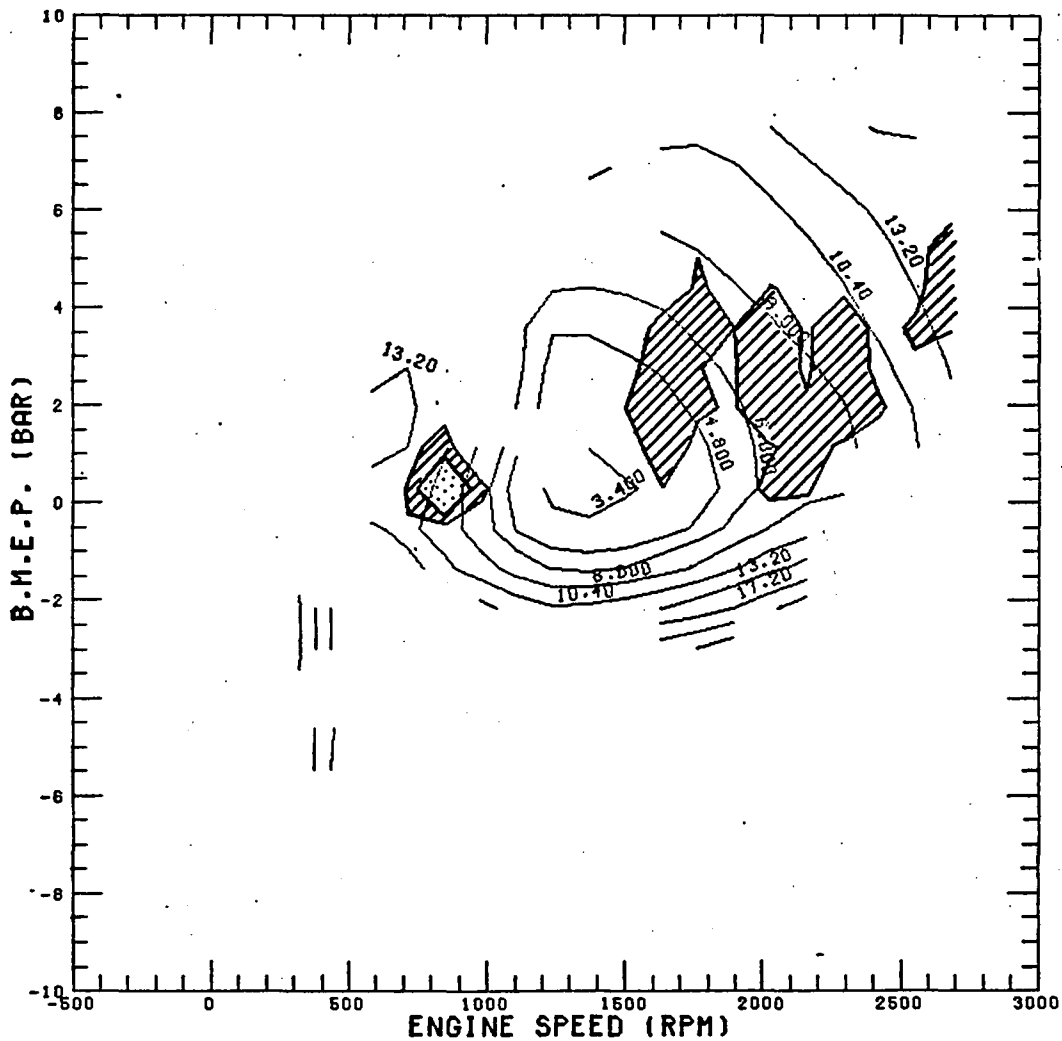

70 HP TC E.G.R.

CO - EMISSION (G/H)

1372.0 SEC US-CITY TEST DATE 18/05/77 11.01.27

TEST RESULT 10.49 G/ 7.45 MI = 1.41 G/MI

SHADED REGIONS 5-12 0.90 G

VEHICLE 1020 KD MASS. 0.80 SQM CM*F. 1.75 % ROLLING DRAG
TRANSMISSION AXLE/GEAR COMBINATION NO. 8

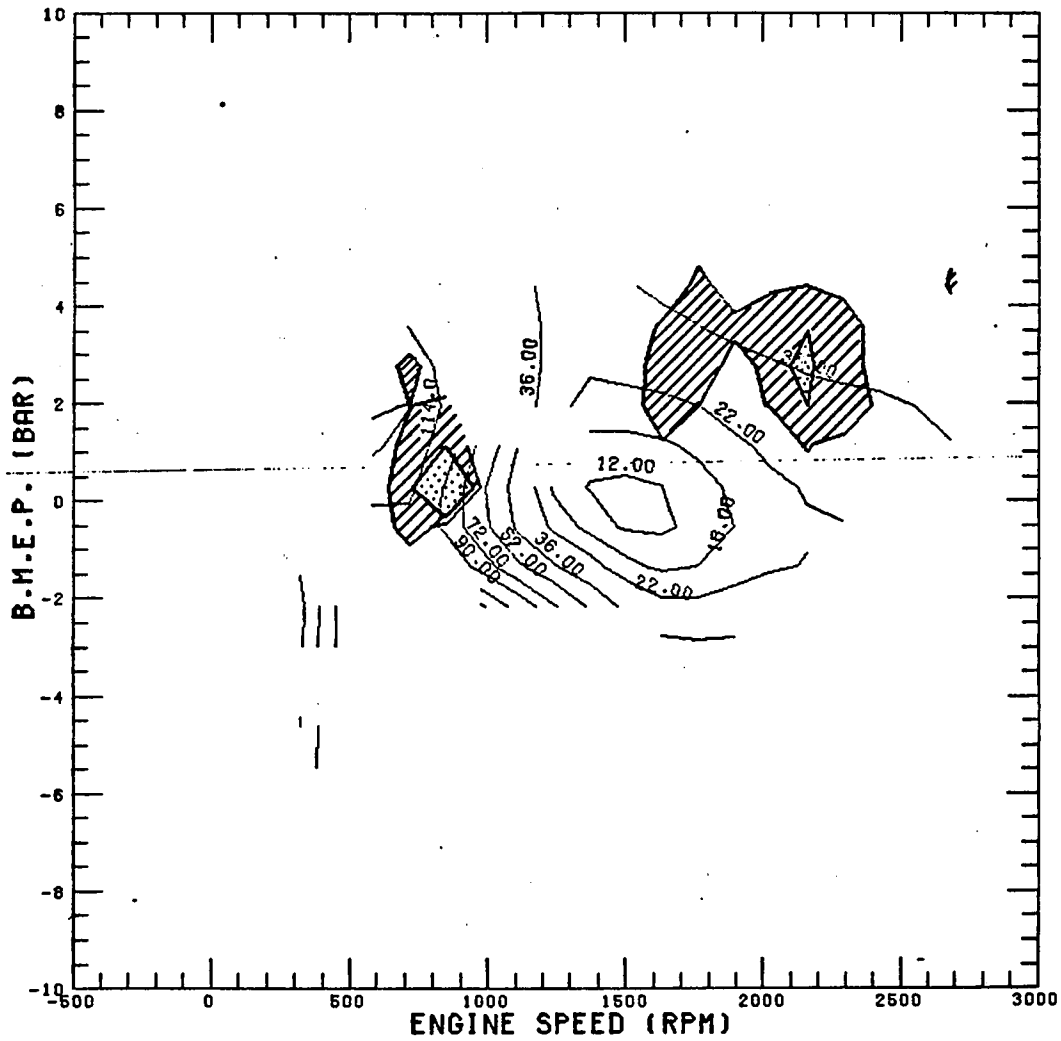

70 HP TC E.G.R.

NOX - EMISSION (G/H)

1372.0 SEC US-CITY TEST DATE 18/05/77 11.01.27

TEST RESULT 2.40 G/ 7.45 MI = 0.32 G/MI

SHADED REGIONS 1.19 0.25 G

VEHICLE 1020 KG MASS. 0.80 SQM CW*F. 1.75 % ROLLING DRAG
TRANSMISSION AXLE/GEAR COMBINATION NO. 8

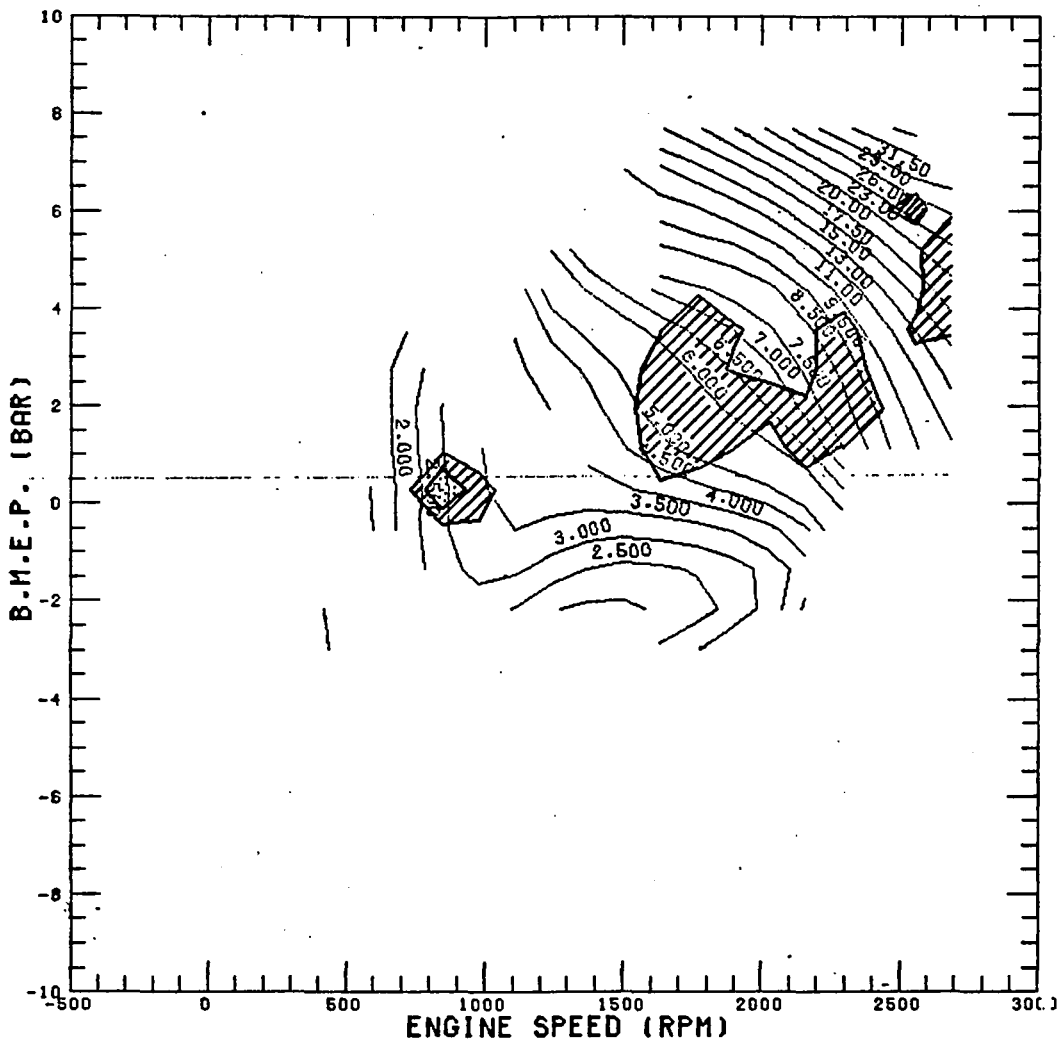

70 HP TC E.G.R.

FUEL CONSUMPTION (KG/H)

764.0 SEC HIGHWAY TEST DATE 18/05/77 · 14.21.38

TEST RESULT 671.84 G/ 10.25 MI = 47.76 MPG

SHADED REGIONS 337.47 93.14 M

VEHICLE 1020 KG MASS, 0.80 SQM CW*F, 1.75 % ROLLING DRAG
TRANSMISSION AXLE/GEAR COMBINATION NO. 8

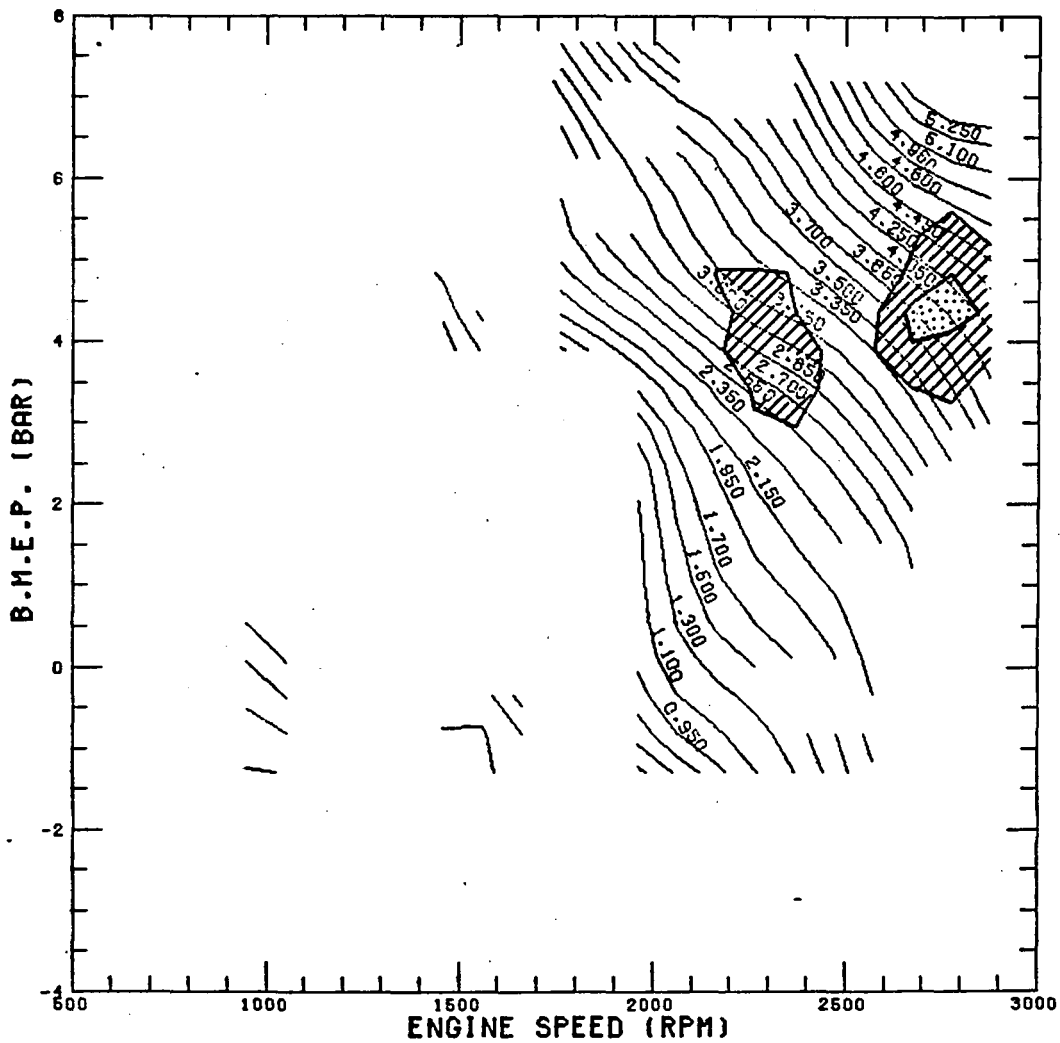

70 HP TC E.G.R.

AIR TO FUEL RATIO

764.0 SEC HIGHWAY TEST DATE 18/05/77 14.21.38

TEST RESULT 764.25 S/ 10.25 MI = 48.28 MPH

SHADED REGIONS 391.75 88.87 M

VEHICLE 1020 KG MASS. 0.80 SQM CH²F. 1.75 % ROLLING DRAG
TRANSMISSION AXLE/GEAR COMBINATION NO. 8

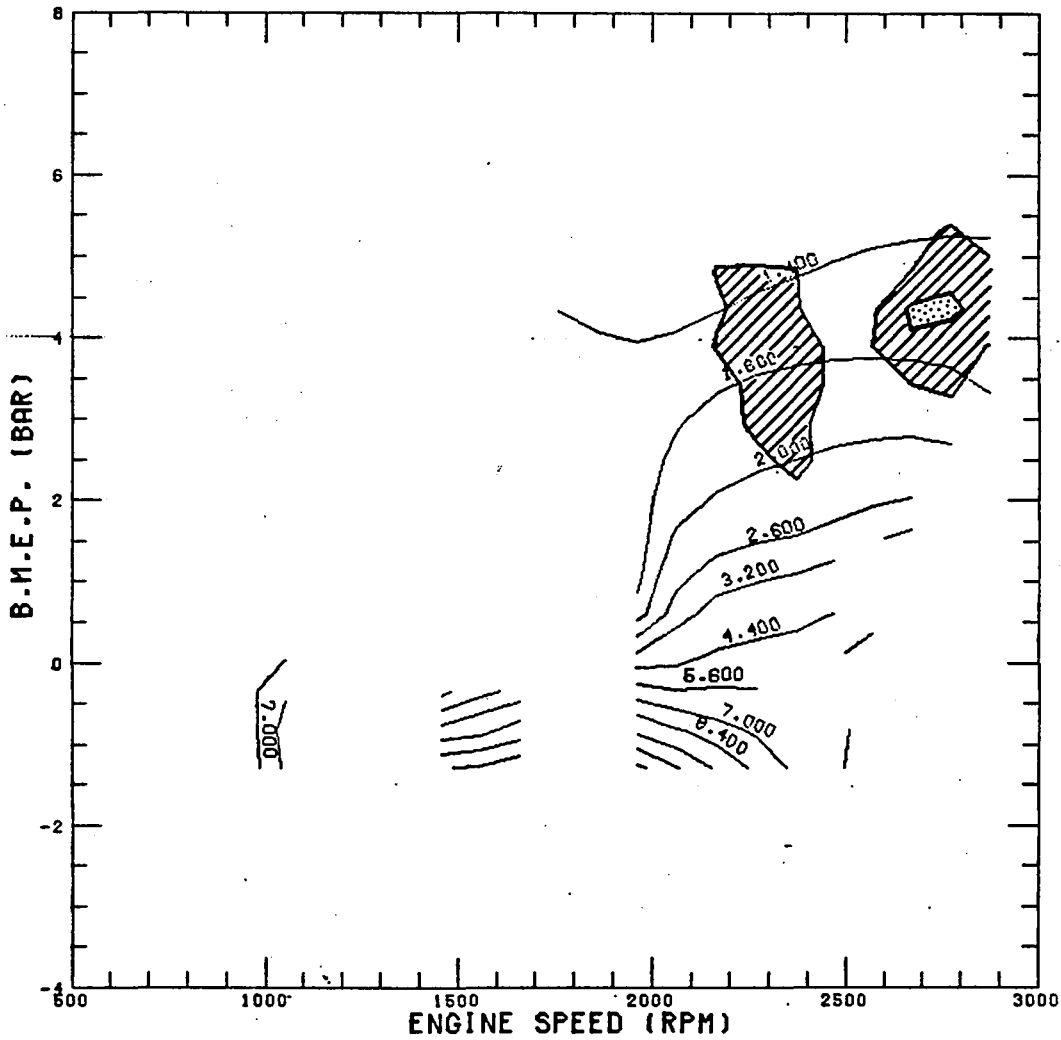

70 HP TC E.G.R.

HC - EMISSION (G/H)

764.0 SEC HIGHWAY TEST DATE 18/05/77 14-21-38

TEST RESULT 2.24 G/ 10.25 MI = 0.22 G/MI

SHADED REGIONS 1-12 0-15 G

VEHICLE 1020 KG MASS, 0.80 SQM CW=F, 1.75 % ROLLING DRAG
TRANSMISSION AXLE/GEAR COMBINATION NO. 8

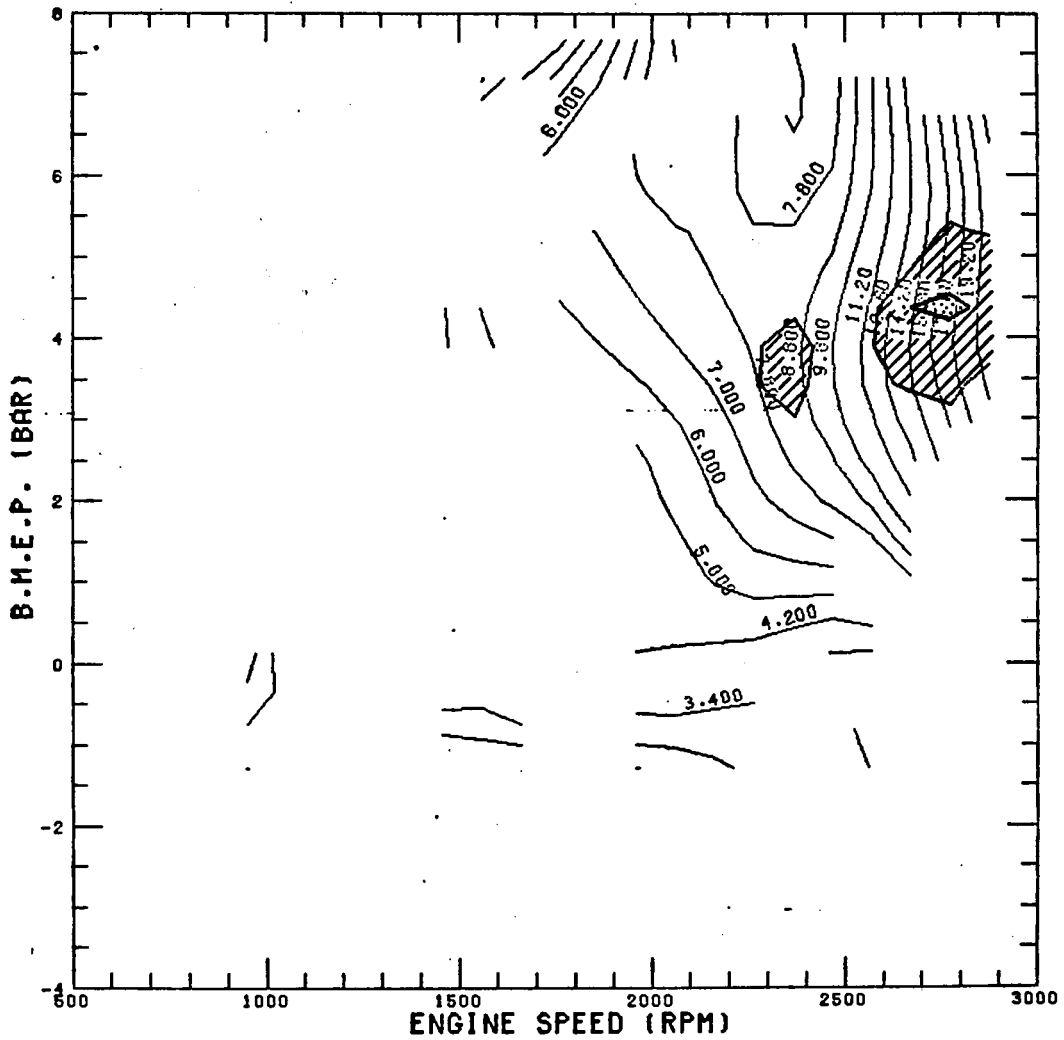

70 HP TC E.G.R.

CO - EMISSION (G/H)

764.0 SEC HIGHWAY TEST DATE 18/05/77 14.21.38

TEST RESULT 14.22 G/ 10.25 MI = 1.39 G/MI

SHADED REGIONS 7.18 1.46 G

VEHICLE 1020 KG MASS, 0.80 SQM CW*F, 1.75 % ROLLING DRAG
TRANSMISSION AXLE/GEAR COMBINATION NO. 8

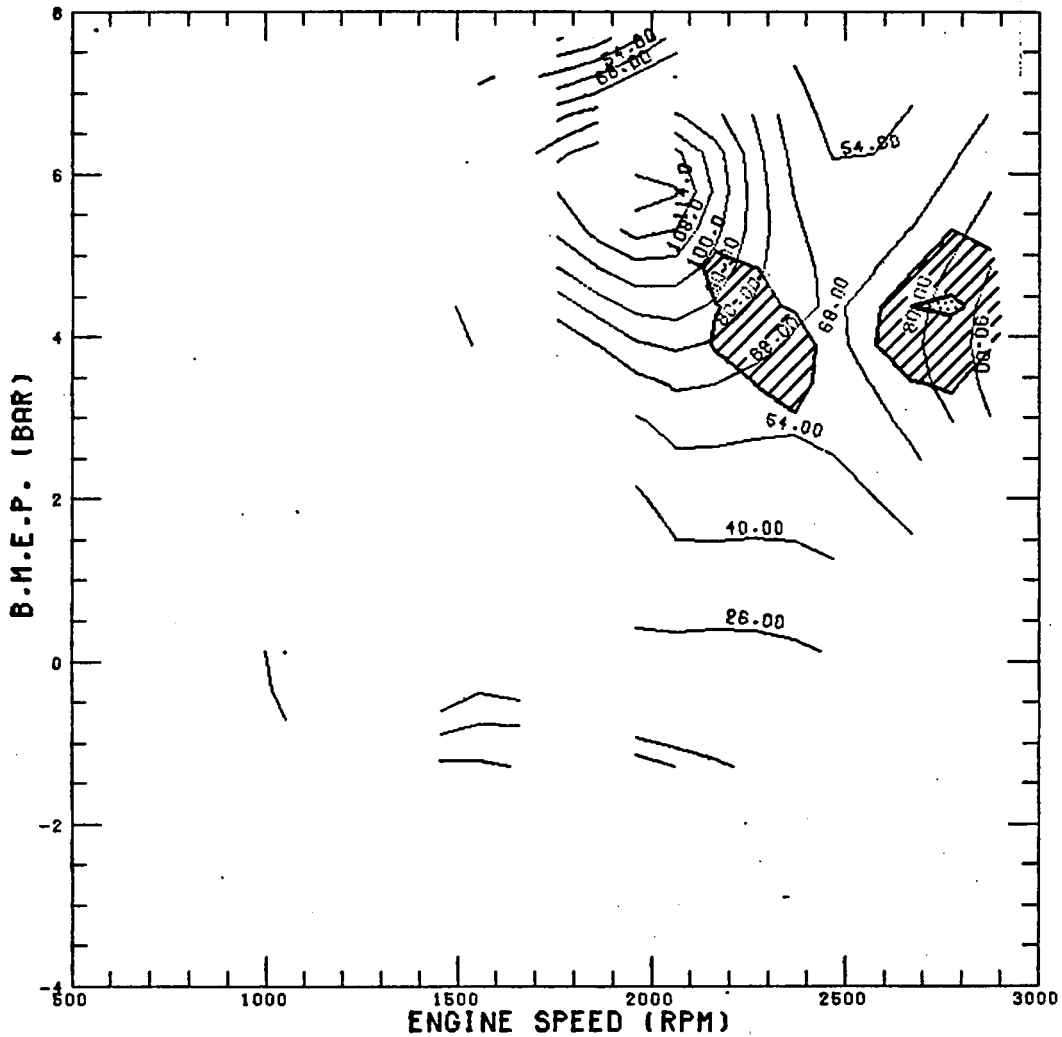

70 HP TC E.G.R.

NOX - EMISSION (G/H)

764.0 SEC HIGHWAY TEST DATE 18/05/77 14.21.38

TEST RESULT 2.49 G/ 10.25 MI = 0.24 G/MI

SHADED REGIONS 1.23 0.15 G

VEHICLE 1020 KG MASS, 0.80 SQM CWAF, 1.75 % ROLLING DRAG
TRANSMISSION AXLE/GEAR COMBINATION NO. 8

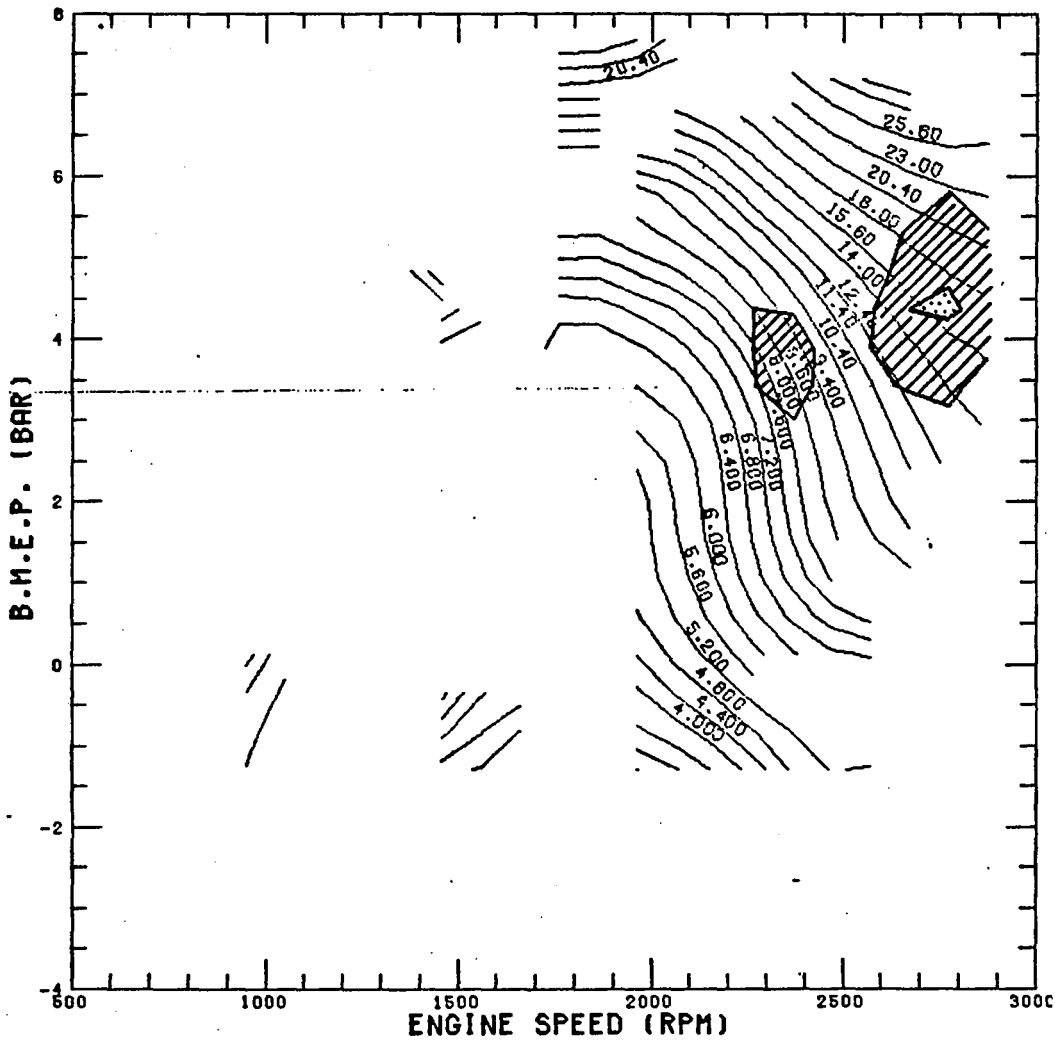

5 CYL. N.A. 130 CID

FUEL CONSUMPTION (KG/H)

1372.0 SEC US-CITY TEST DATE 15/09/76, 15.27.40

TEST RESULT 670.11 G/ 7.45 MI = 35.05 MPG

SHADED REGIONS 337.91 56.98 M

VEHICLE 1362 KG MASS, 0.80 SQM CM²F, 1.75 % ROLLING DRAG
TRANSMISSION AXLE/GEAR COMBINATION NO. 8

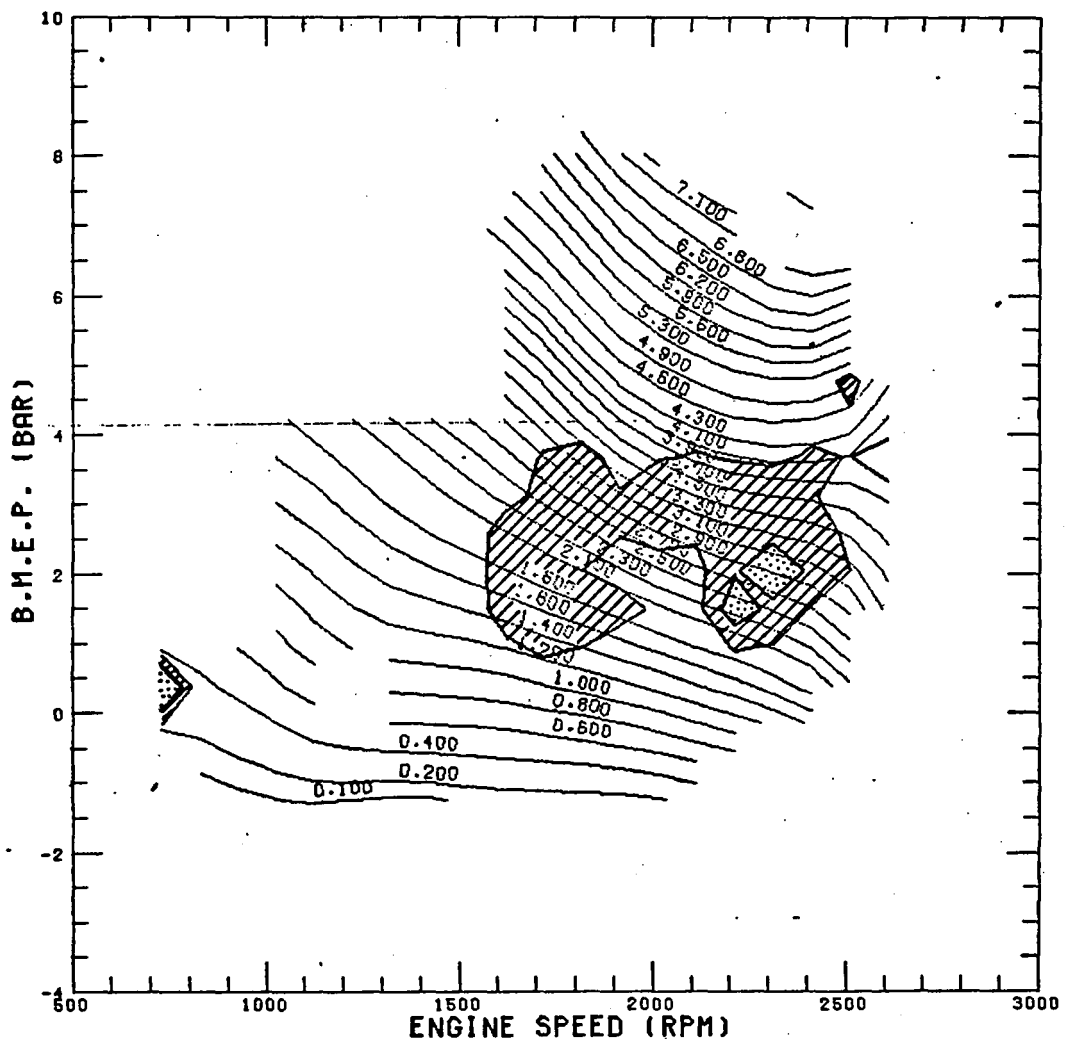

5 CYL. N.A. 130 CID

AIR TO FUEL RATIO

1372.0 SEC US-CITY TEST DATE 15/09/76 15-27-40

TEST RESULT 1372.25 S/ 7.45 MI = 19.54 MPH

SHADED REGIONS 688.75 229.87 M

VEHICLE 1362 KG MASS. 0.80 SQM CW=F. 1.75 % ROLLING DRAG
TRANSMISSION AXLE/GEAR COMBINATION NO. 8

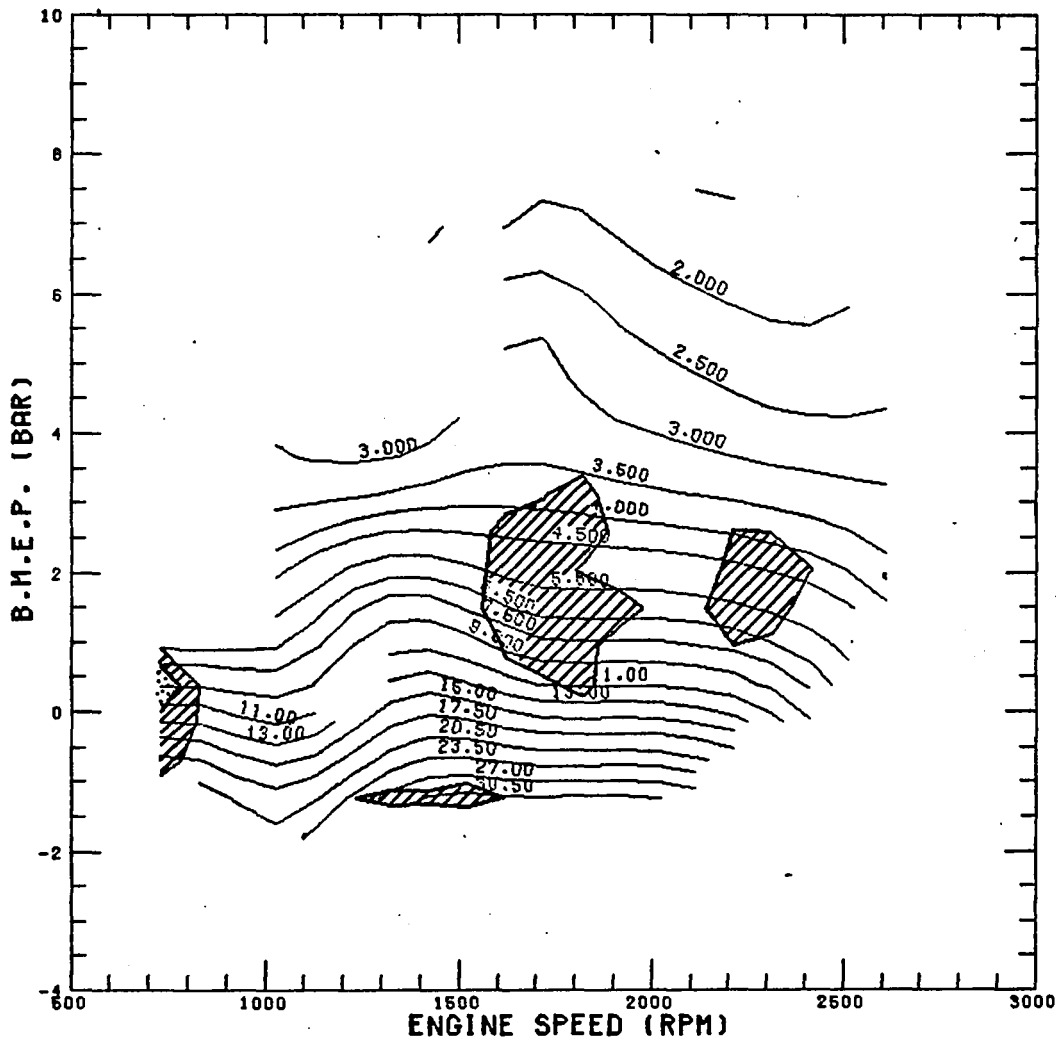

5 CYL. N.A. 130 CID

HC - EMISSION (G/H)

1372.0 SEC US-CITY TEST DATE 15/09/76 15.27.40

TEST RESULT 2.35 G/ 7.45 MI = 0.32 G/MI

SHADED REGIONS 1.19 0.23 G

VEHICLE 1362 KG MASS, 0.80 SQM CW*F, 1.75 % ROLLING DRAG

TRANSMISSION AXLE/GEAR COMBINATION NO. 8

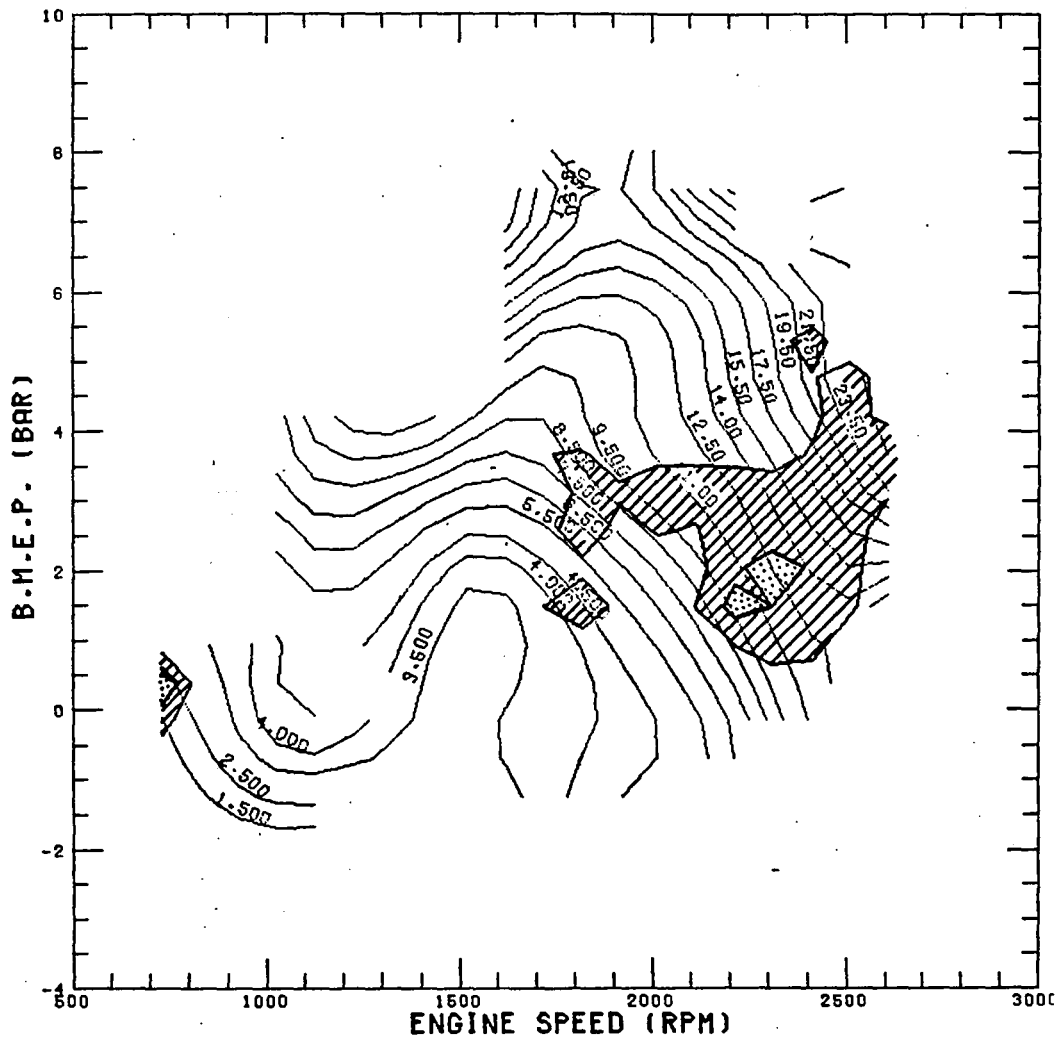

5 CYL. N.A. 130 CID

CO - EMISSION (G/H)

1372.0 SEC US-CITY TEST DATE 15/09/76 15.27.40

TEST RESULT 17.44 G/ 7.45 MI = 2.34 G/MI

SHADED REGIONS 8.61 2.03 G

VEHICLE 1362 KG MASS, 0.80 SON CW*F, 1.75 % ROLLING DRAG
TRANSMISSION AXLE/GEAR COMBINATION NO. 8

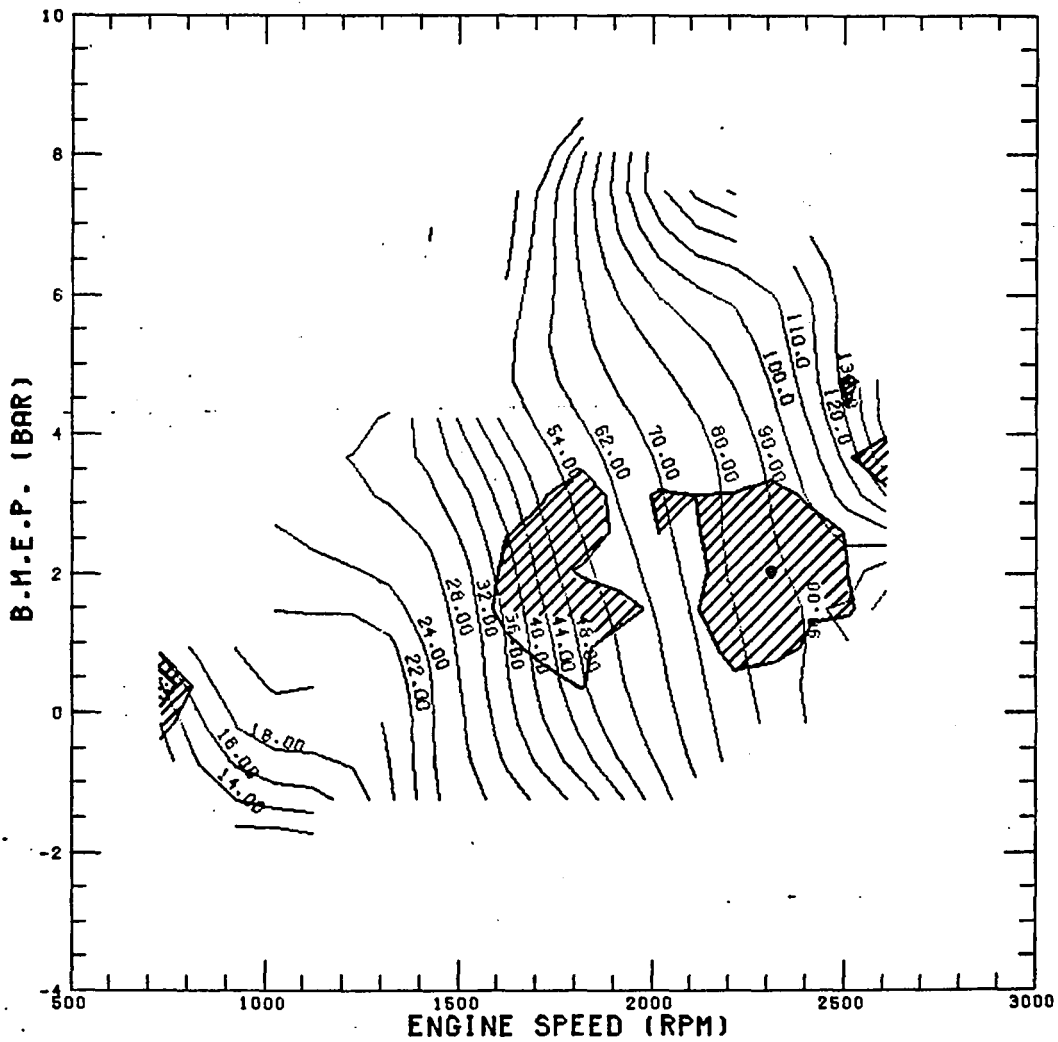

5 CYL. N.A. 130 CID

NOX - EMISSION (G/H)

1372.0 SEC US-CITY TEST DATE 15/09/76 15.27.40

TEST RESULT 11.13 G/ 7.45 MI = 1.49 G/MI

SHADED REGIONS 5.56 1.10 G

VEHICLE 1362 KG MASS, 0.80 SQM CW*F, 1.75 % ROLLING DRAG
TRANSMISSION AXLE/GEAR COMBINATION NO. 8

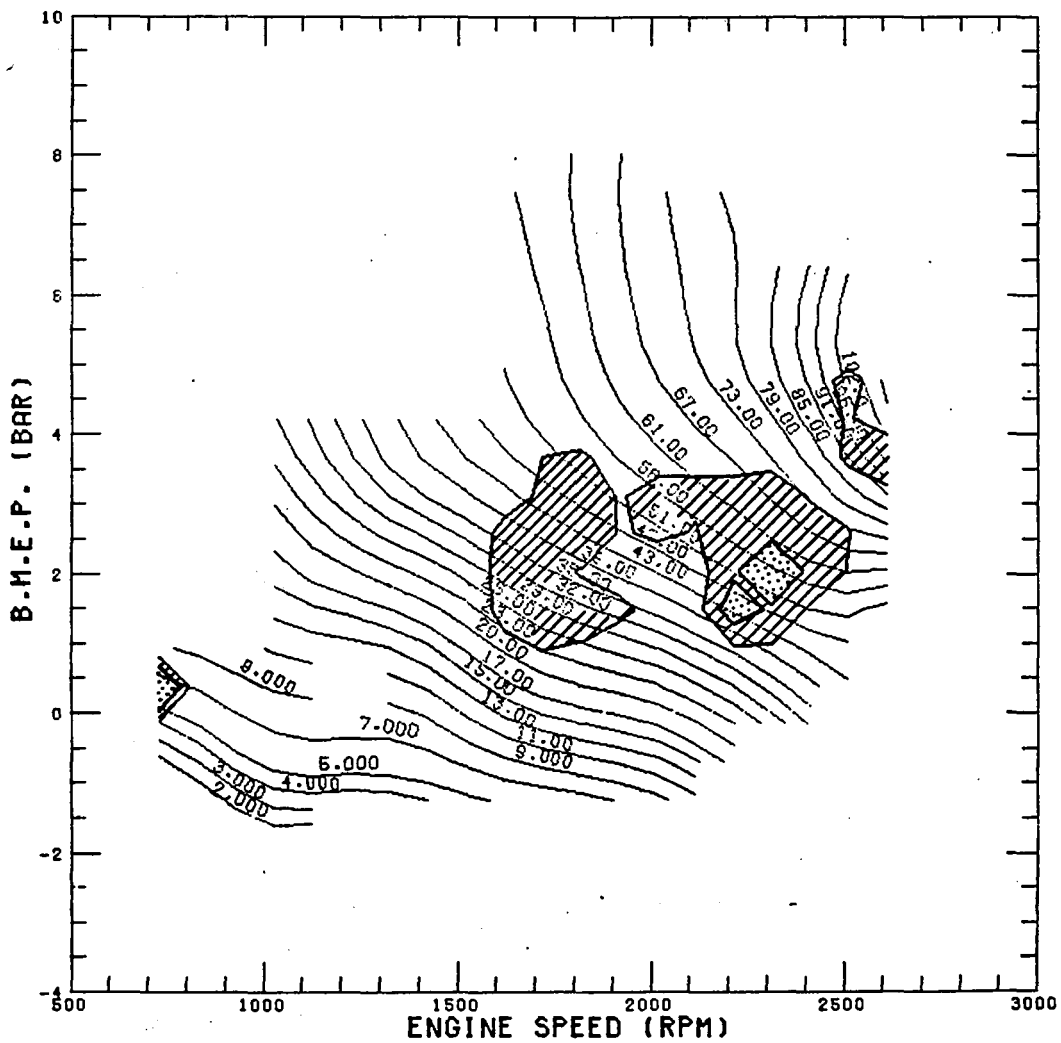

5 CYL. N.A. 130 CID

FUEL CONSUMPTION (KG/H)

764.0 SEC HIGHWAY TEST DATE 15/09/76 15.49.37

TEST RESULT 810.15 G/ 10.25 MI = 39.89 MPG

SHADED REGIONS 409.52 93.46 M

VEHICLE 1362 KG MASS, 0.80 SQM CW*F, 1.75 % ROLLING DRAG
TRANSMISSION AXLE/GEAR COMBINATION NO. 8

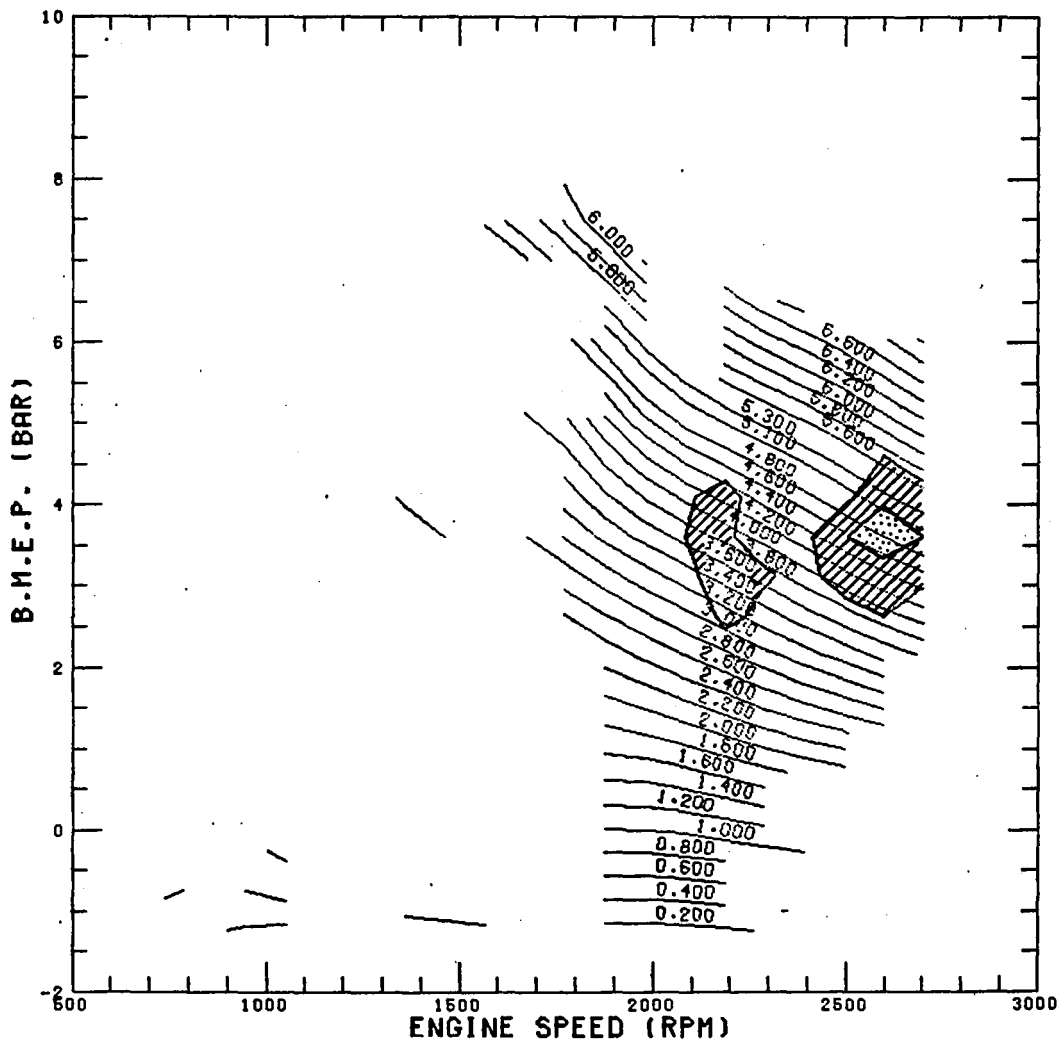

5 CYL. N.A. 130 CID

AIR TO FUEL RATIO

764.0 SEC HIGHWAY TEST DATE 15/09/76 15.49.37

TEST RESULT 764.25 S/ 10.25 MI = 48.28 MPH

SHADED REGIONS 389.37 78.25 M

VEHICLE 1362 KG MASS, 0.80 SQM CW*F, 1.75 % ROLLING DRAG

TRANSMISSION AXLE/GEAR COMBINATION NO. 8

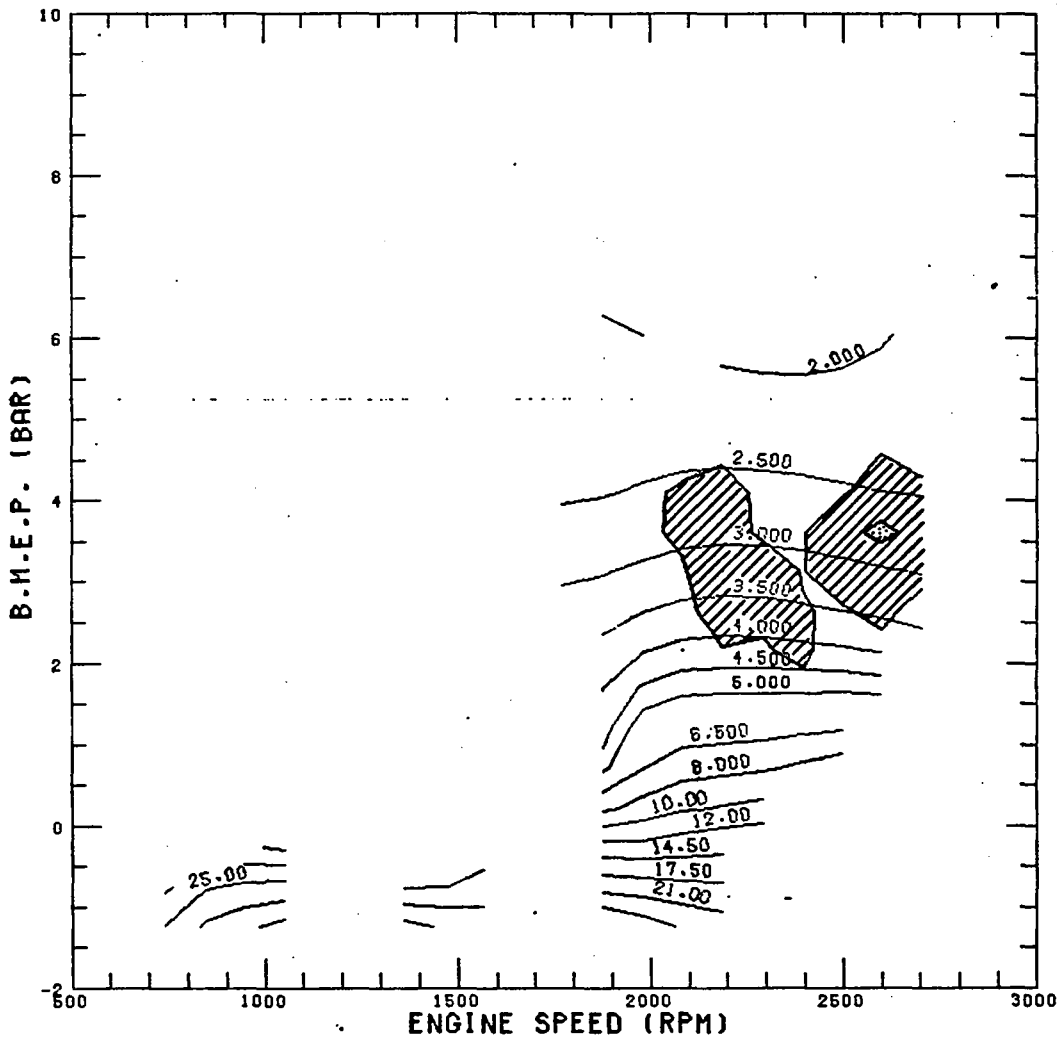

5 CYL. N.A. 130 CID

HC - EMISSION (G/H)

764.0 SEC HIGHWAY TEST DATE 15/09/76 15.49.37

TEST RESULT 4.90 G/ 10.25 MI = 0.48 G/MI

SHADED REGIONS 2.45 0.53 G

VEHICLE 1362 KG MASS, 0.80 SQM CW*F, 1.75 % ROLLING DRAG
TRANSMISSION AXLE/GEAR COMBINATION NO. 6

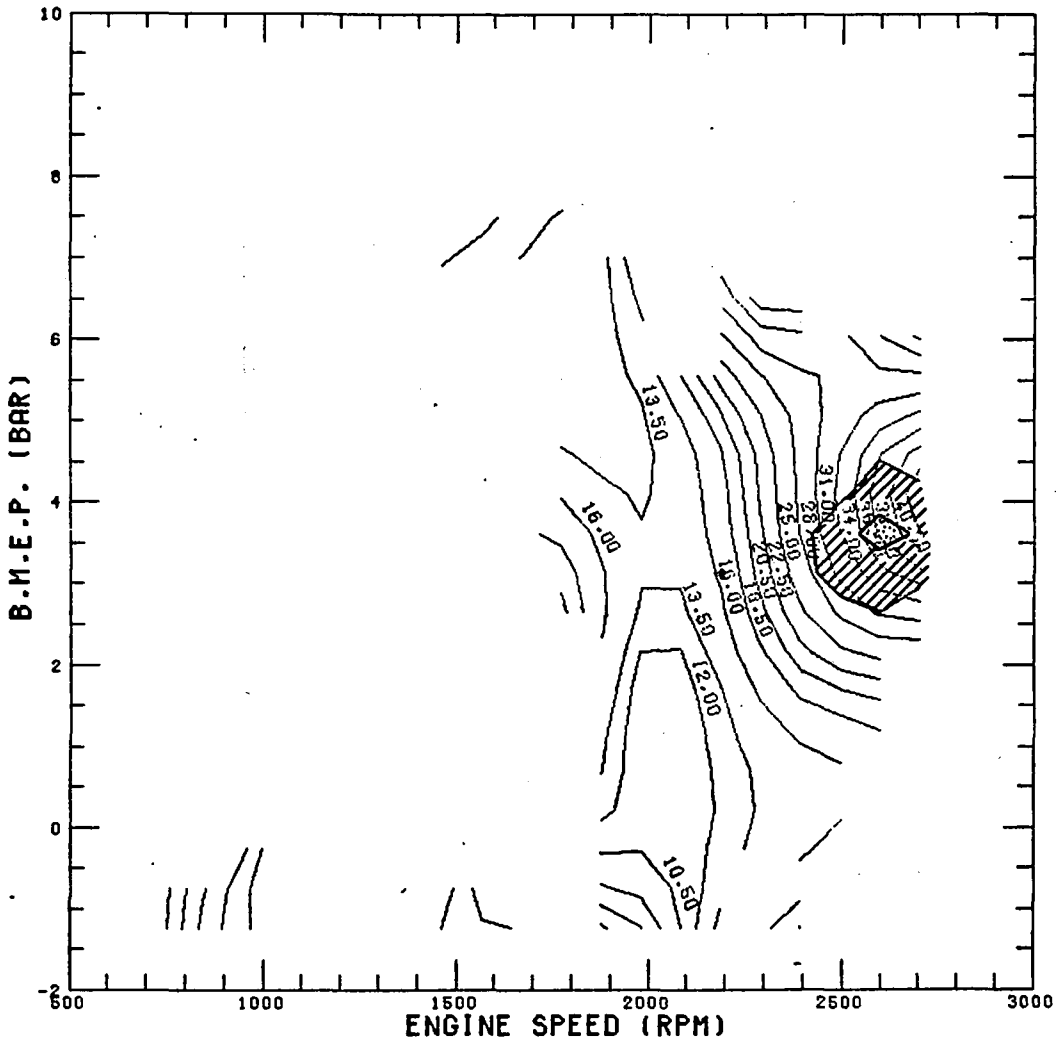

5 CYL. N.A. 130 CID

AIR TO FUEL RATIO

764.0 SEC HIGHWAY TEST DATE 15/09/76 15.49.37

TEST RESULT 764.25 S/ 10.25 MI = 48.28 MPH

SHADED REGIONS 389.37 78.25 M

VEHICLE 1362 KD MASS, 0.80 SQM CW*F, 1.75 % ROLLING DRAG

TRANSMISSION AXLE/GEAR COMBINATION NO. 8

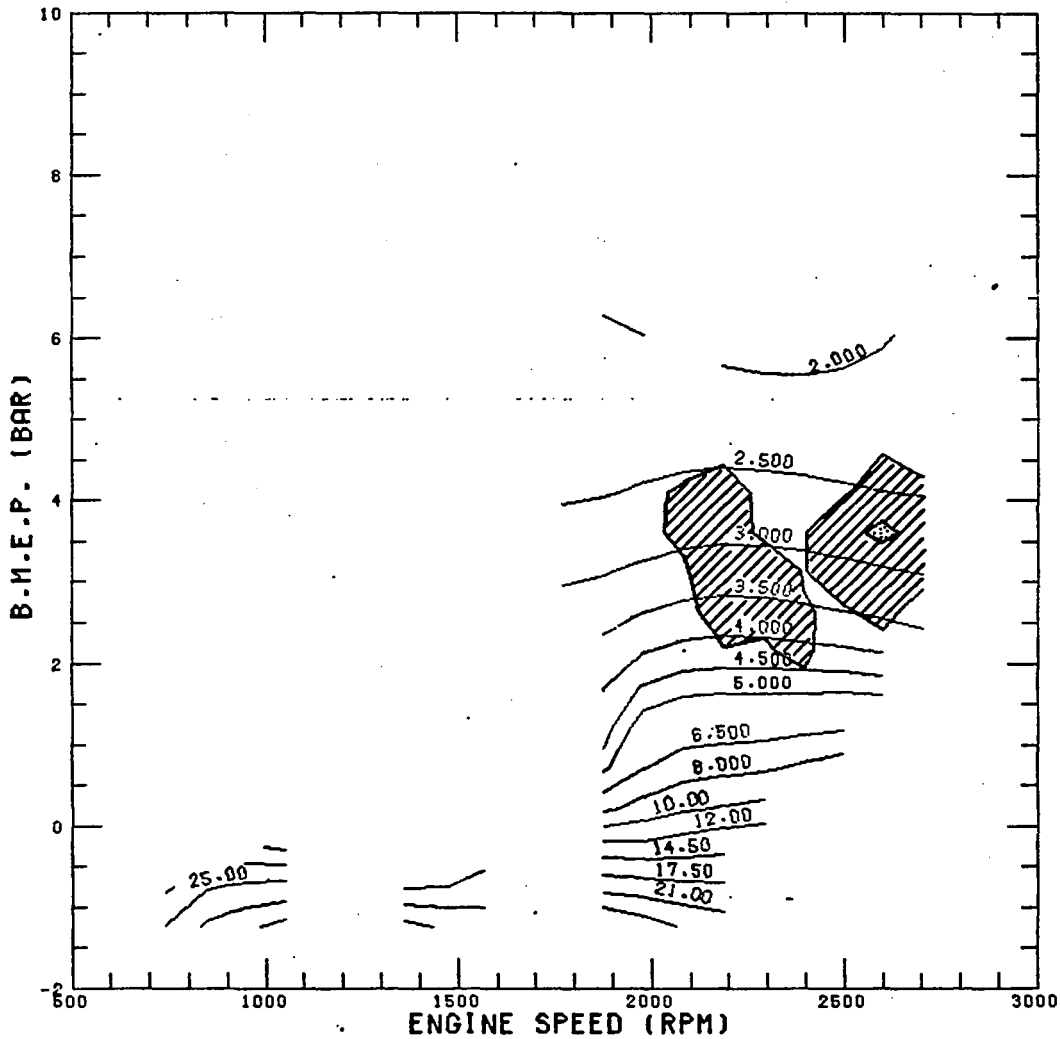

5 CYL. N.A. 130 CID

HC - EMISSION (G/H)

764.0 SEC HIGHWAY TEST DATE 15/09/76 15.49.37

TEST RESULT 4.90 G/ 10.25 MI = 0.48 G/MI

SHADED REGIONS 2.45 0.53 G

VEHICLE 1362 KG MASS, 0.80 SQM CW*F, 1.75 % ROLLING DRAG

TRANSMISSION AXLE/GEAR COMBINATION NO. 8

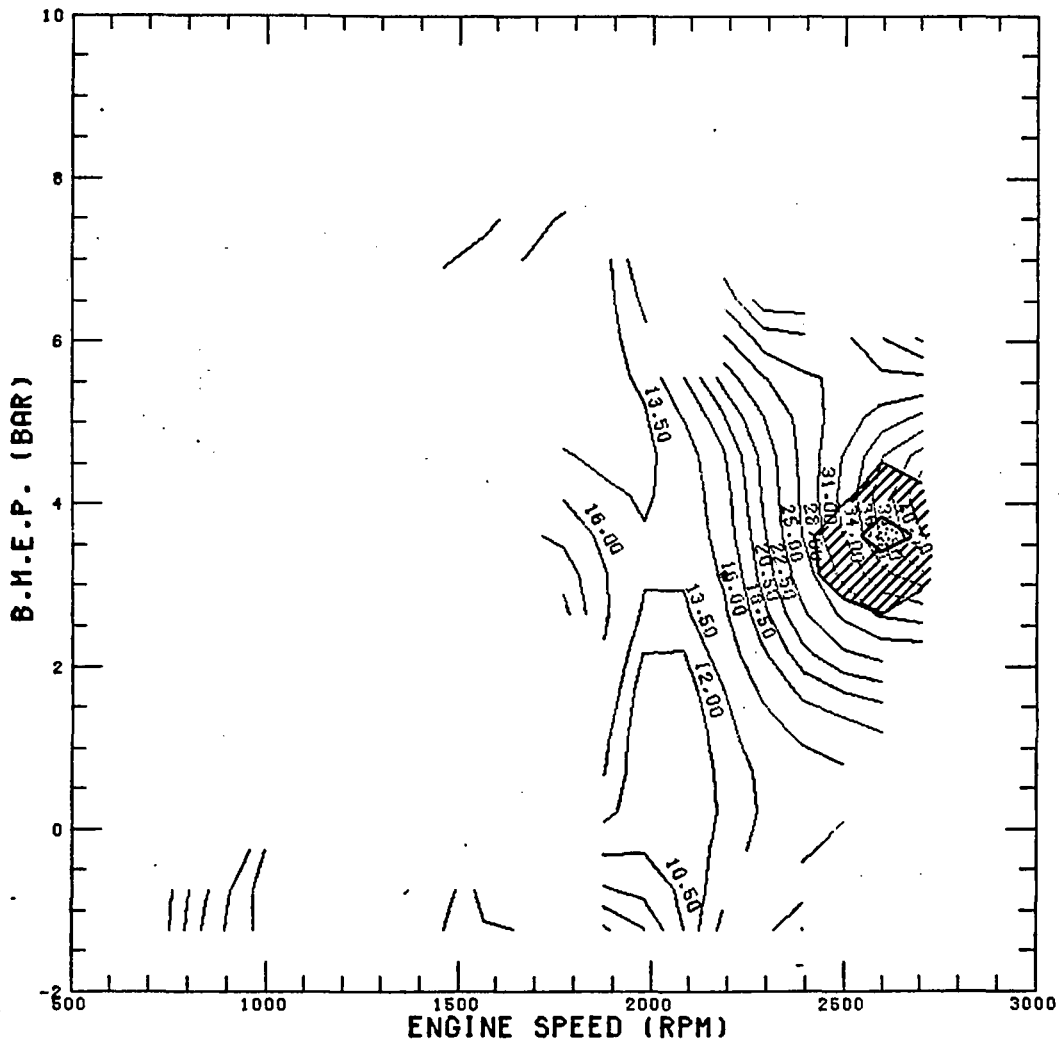

5 CYL. N.A. 130 CID

CO - EMISSION (G/H)

764.0 SEC HIGHWAY TEST DATE 15/09/76 15.49.37

TEST RESULT 23.43 G/ 10.25 MI = 2.29 G/MI

SHADED REGIONS 11.70 2.10 G

VEHICLE 1362 KG MASS. 0.80 SQM CH*F. 1.75 % ROLLING DRAG
TRANSMISSION AXLE/GEAR COMBINATION NO. 8

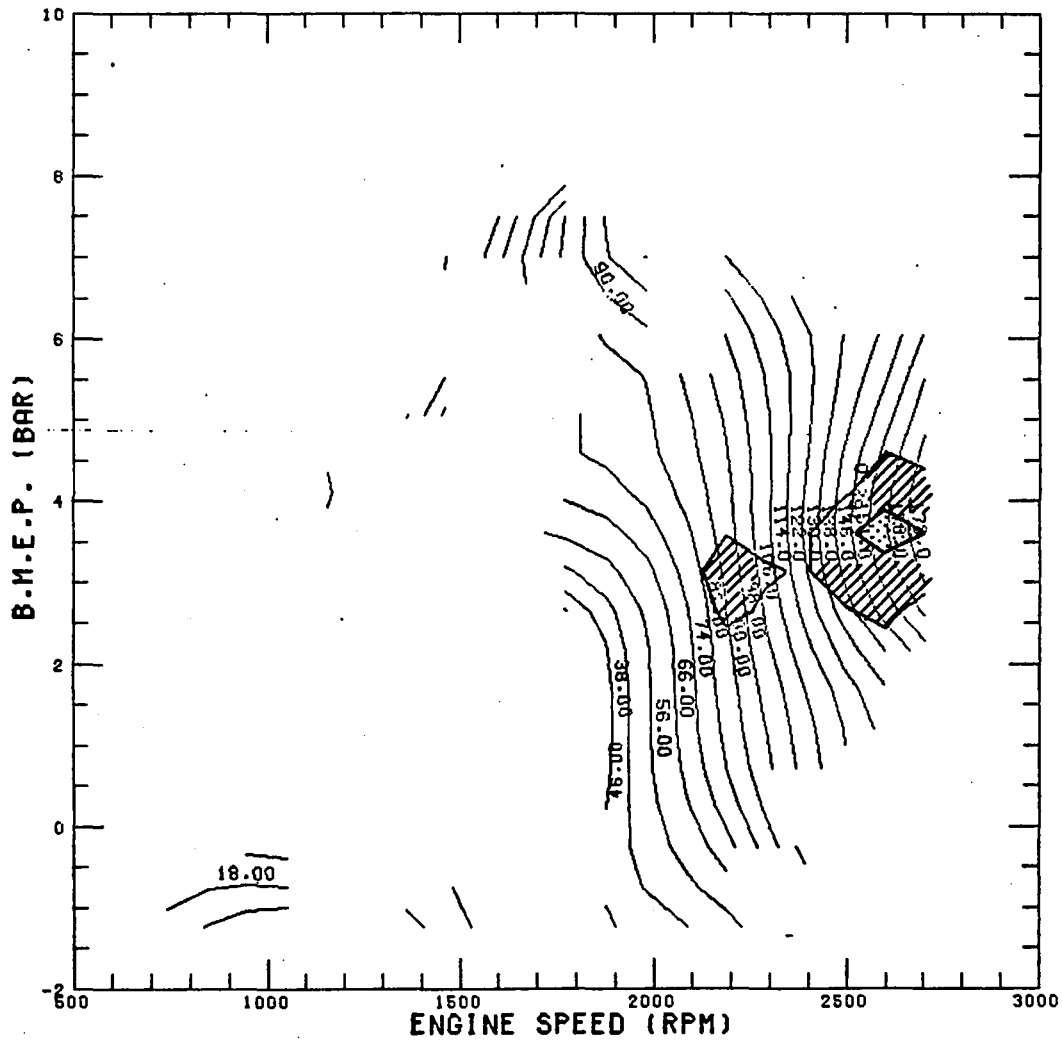

5 CYL. N.A. 130 CID

NOX - EMISSION (G/H)

764.0 SEC HIGHWAY TEST DATE 15/09/76 15.49.37

TEST RESULT 14.72 G/ 10.25 MI = 1.44 G/MI

SHADED REGIONS 7.09 1.20 G

VEHICLE 1362 KG MASS, 0.80 SQM CM²F, 1.75 % ROLLING DRAG
TRANSMISSION AXLE/GEAR COMBINATION NO. 8

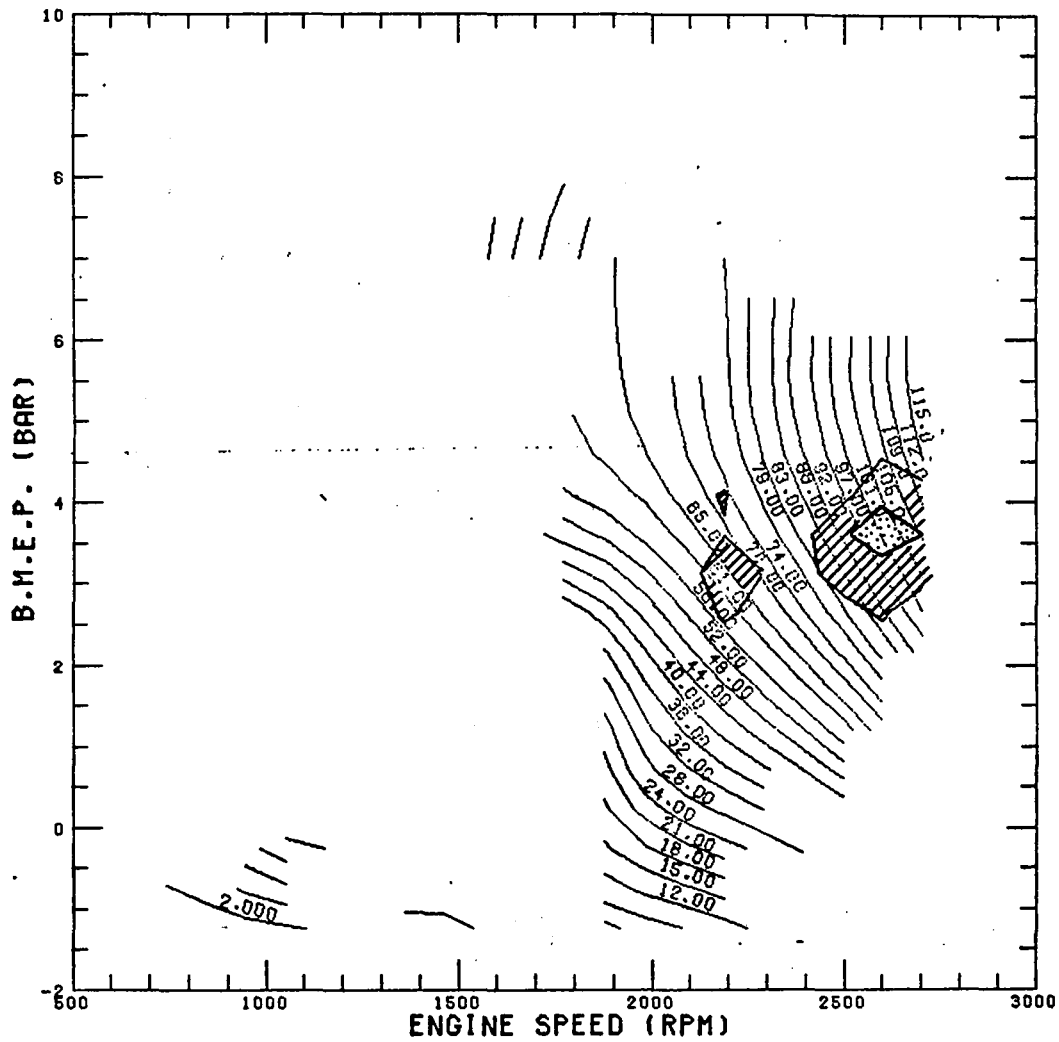

NOISE EMISSION

GOLF D NO. 1 WITH 50 HP PRODUCTION DIESEL

Idle Noise 79 dB(A) exterior

58 dB(A) interior

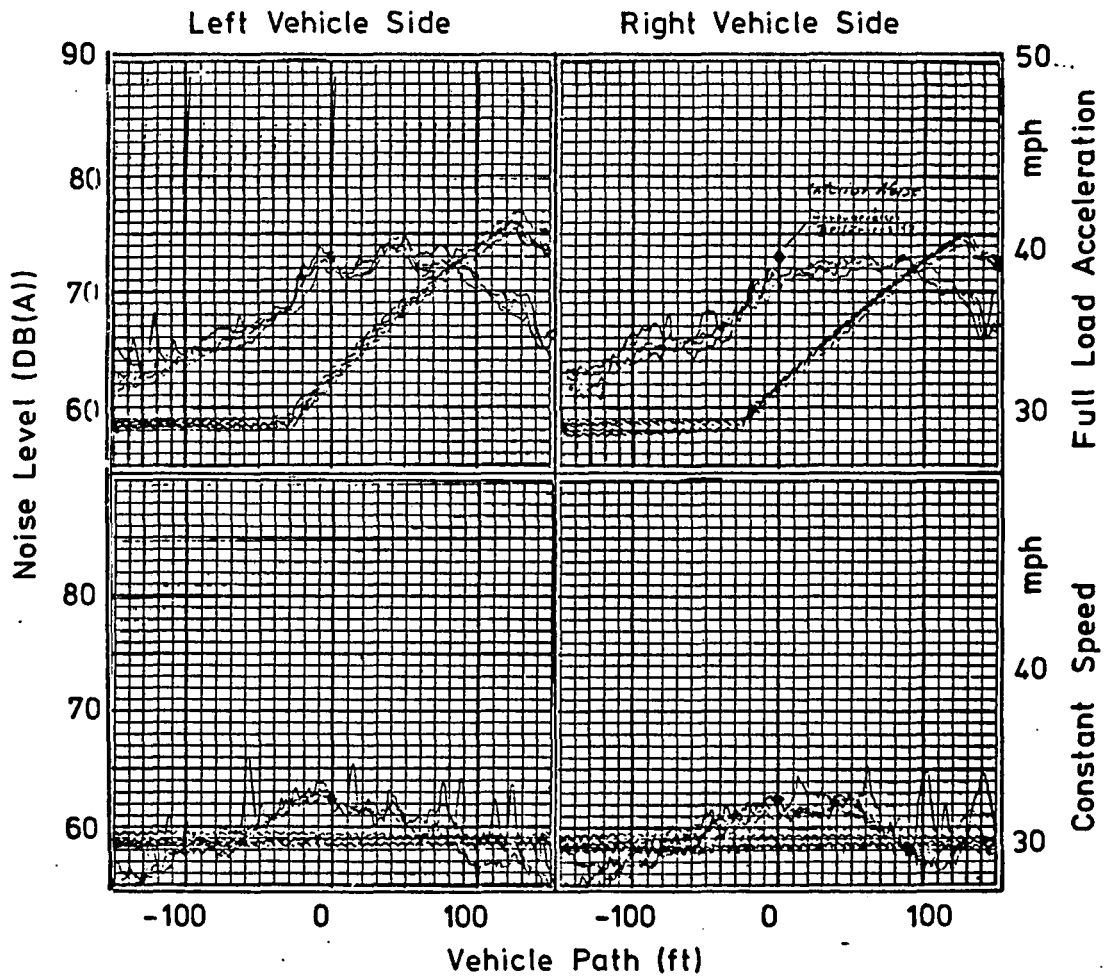

NOISE EMISSION

GOLF D NO. 2 WITH 50 HP PRODUCTION DIESEL

Idle Noise 79 dB(A) exterior

56 dB(A) interior

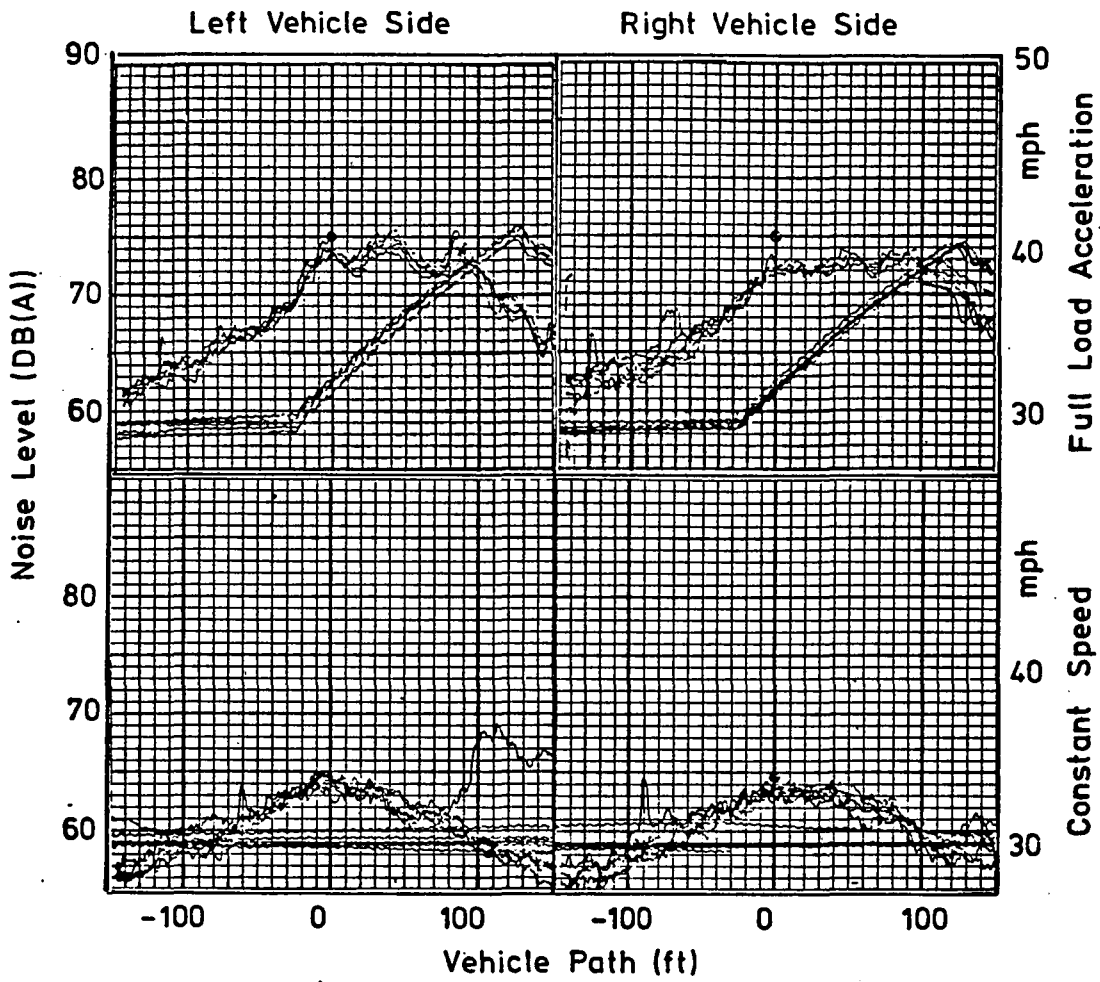

NOISE EMISSION

GOLF D NO. 3 WITH 50 HP PRODUCTION DIESEL

Idle Noise 79 dB(A) exterior

55 dB(A) interior

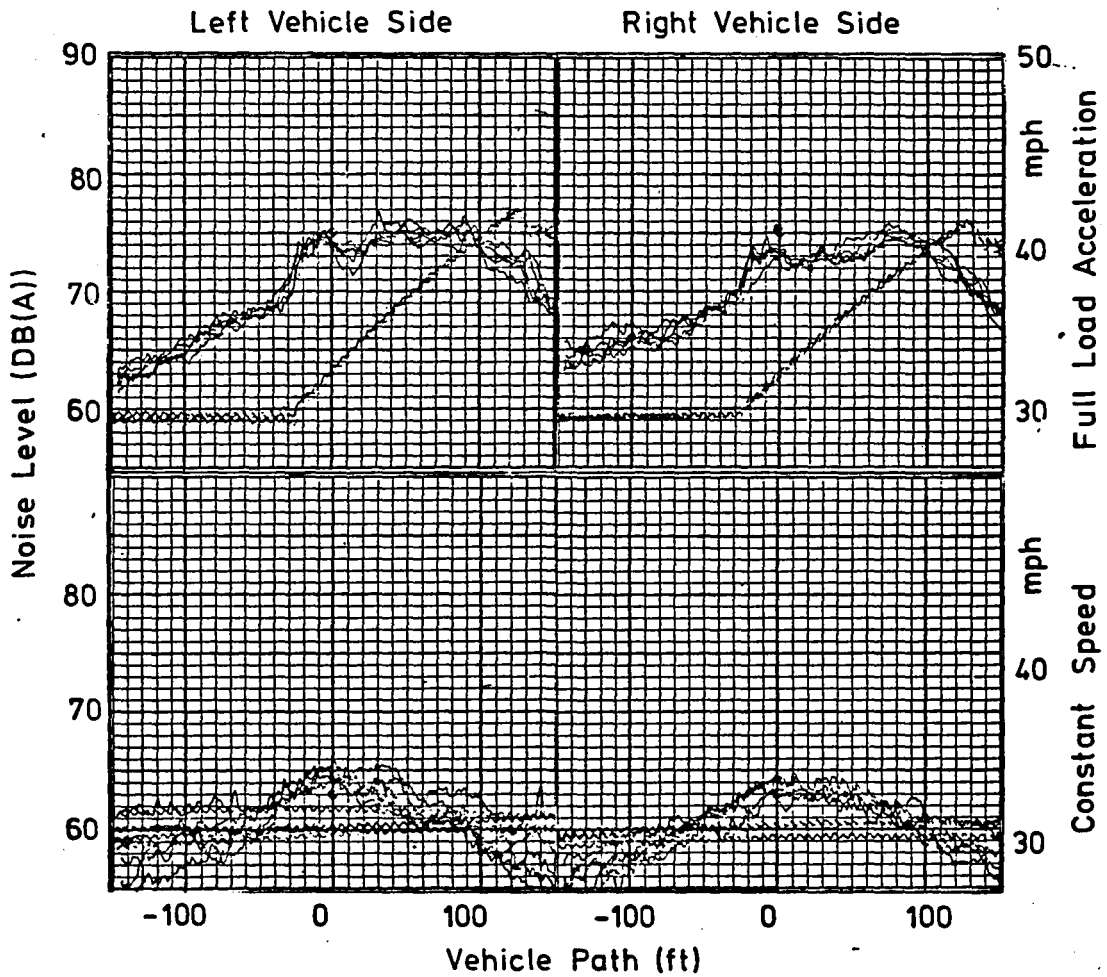

NOISE EMISSION

GOLF D NO. 4 WITH 50 HP PRODUCTION DIESEL

Idle Noise 80 dB(A) exterior

54.5 dB(A) interior

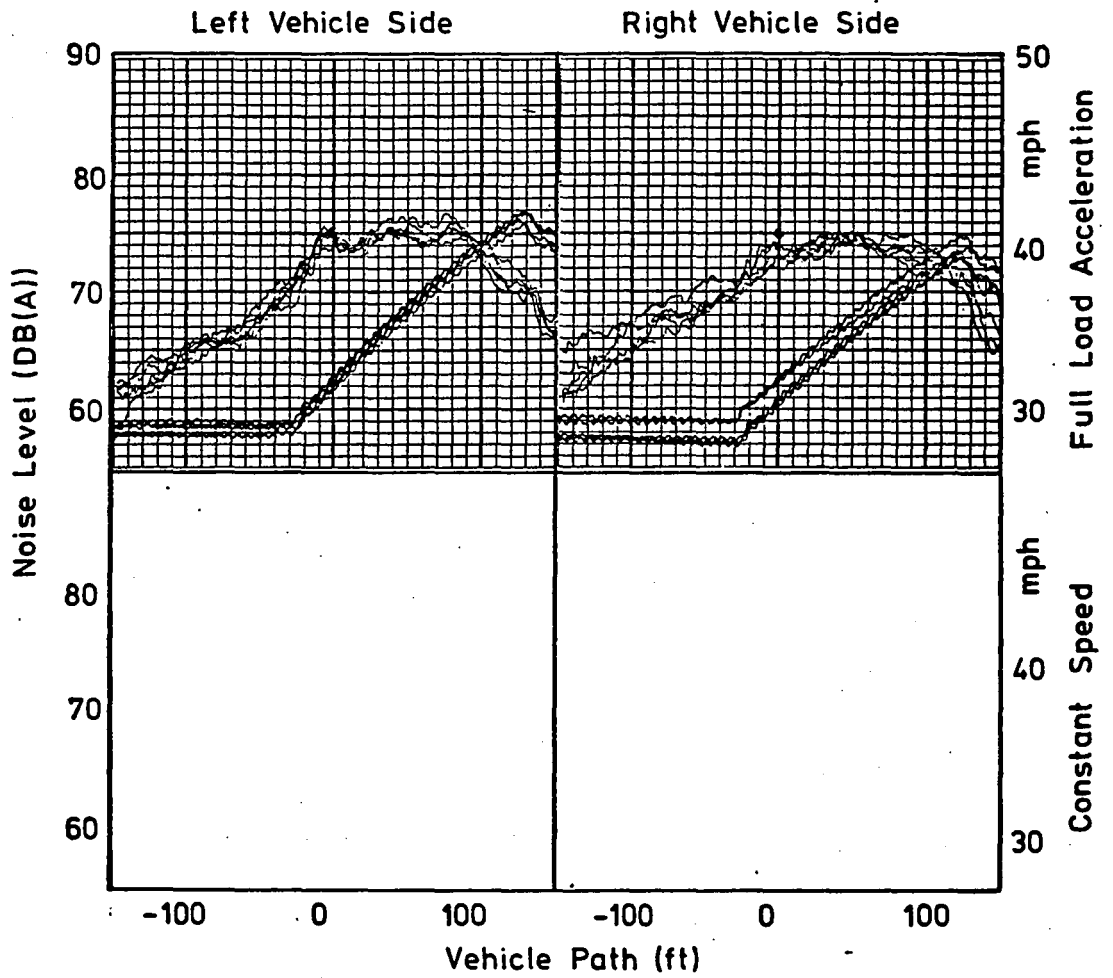

NOISE EMISSION

GOLF D NO. 5 WITH 50 HP PRODUCTION DIESEL
wet surface

Idle Noise 81 dB(A) exterior

56 dB(A) interior

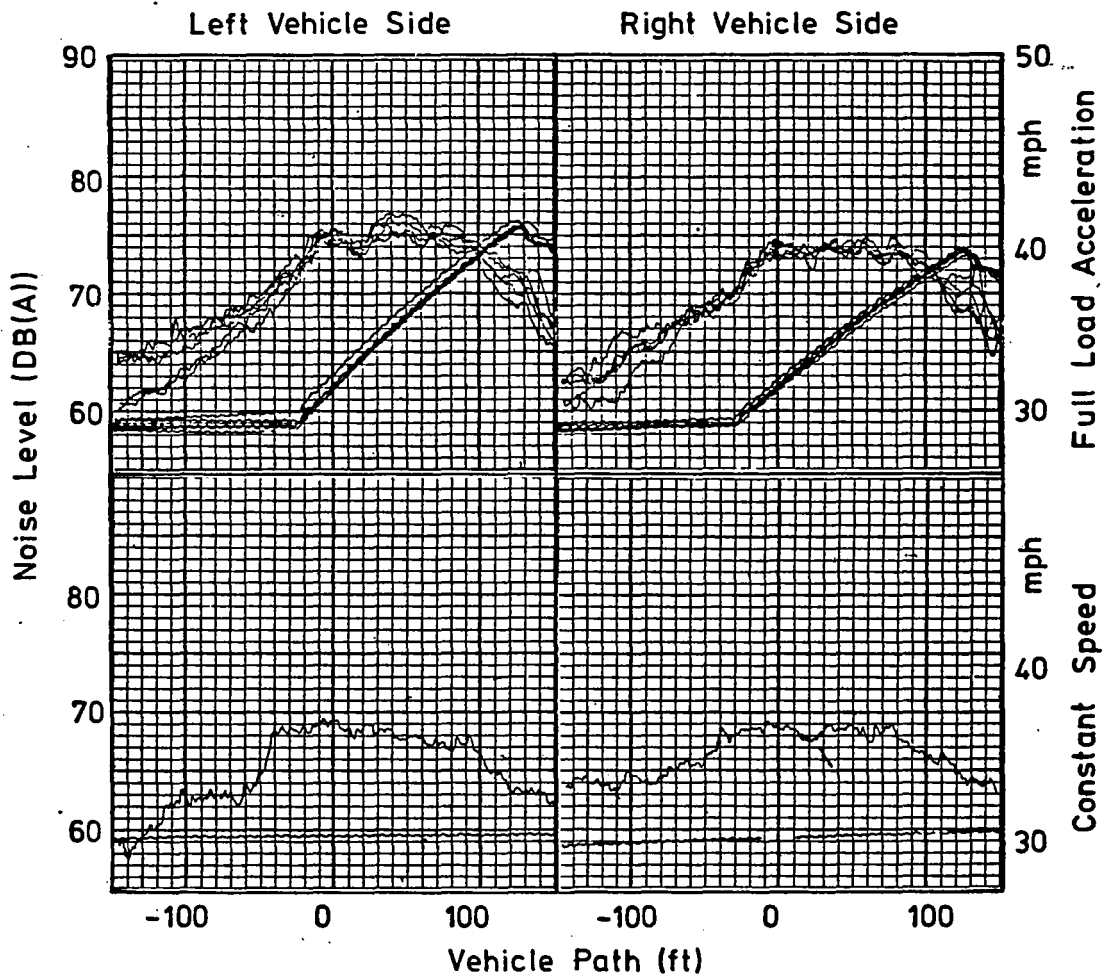

NOISE EMISSION

GOLF D NO. 6 WITH 50 HP PRODUCTION DIESEL
wet surface

Idle Noise 81 dB(A) exterior
55 dB(A) interior

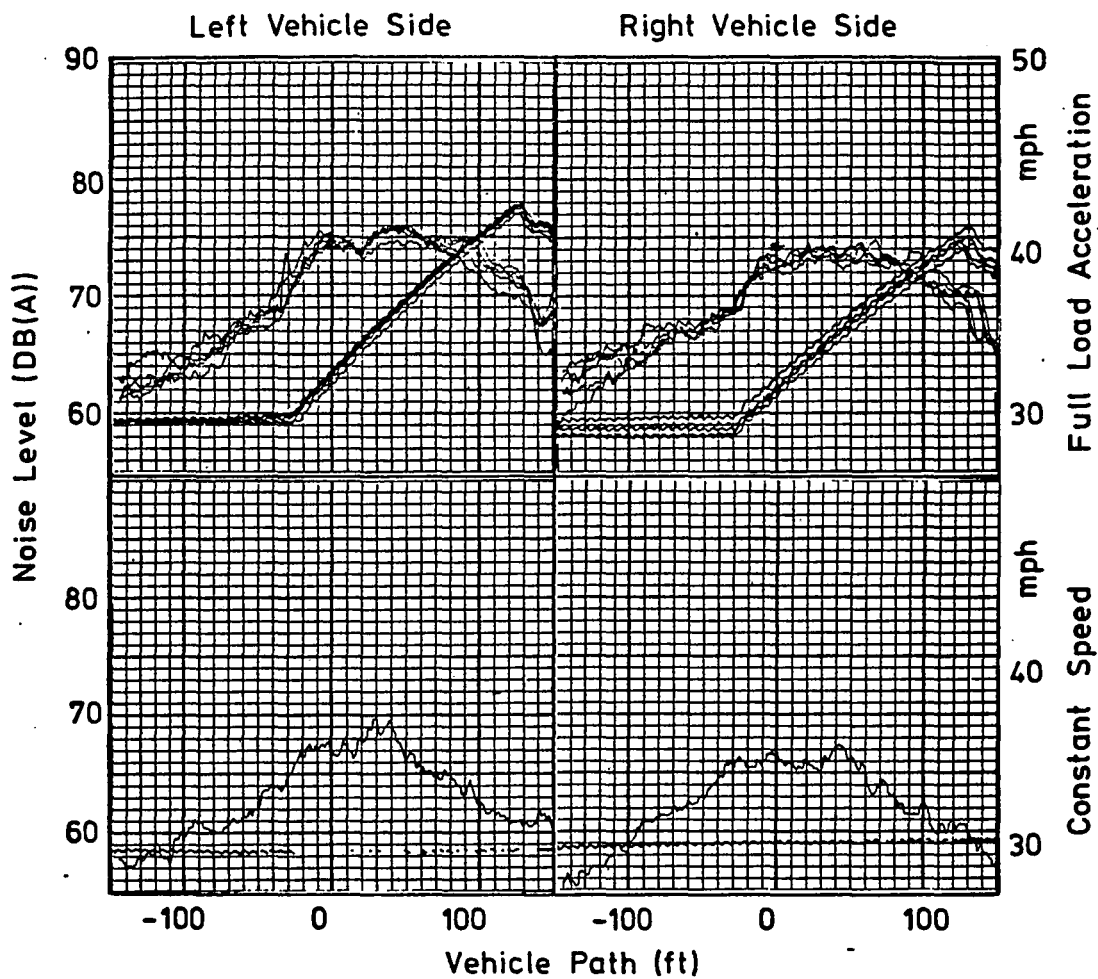

NOISE EMISSION

GOLF LD NO. 1 WITH 50 HP PRODUCTION DIESEL

Idle Noise 79.5 dB(A) exterior

54 dB(A) interior

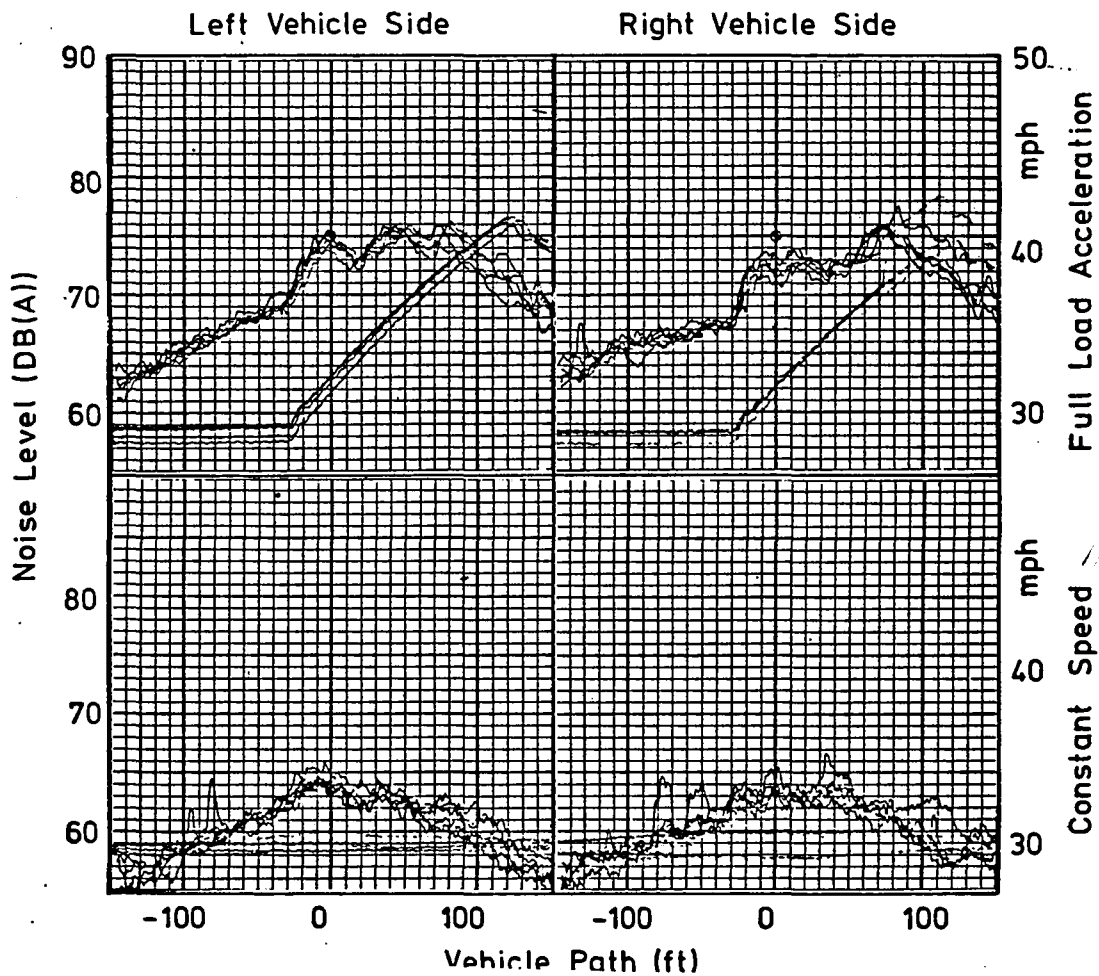

NOISE EMISSION

GOLF LD NO. 2 WITH 50 HP PRODUCTION DIESEL

Idle Noise 81 dB(A) exterior

53.5 dB(A) interior

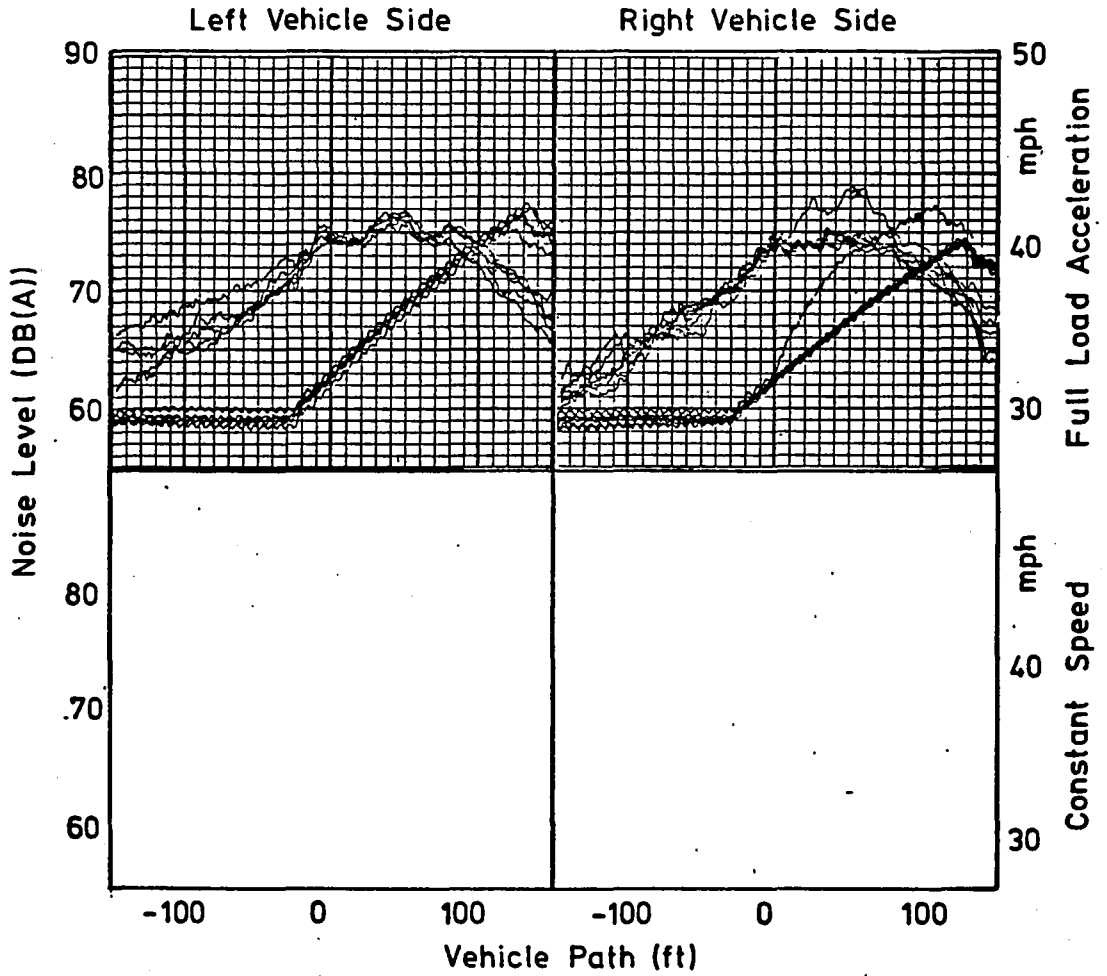

NOISE EMISSION

GOLF GLD NO. 1 WITH 50 HP PRODUCTION DIESEL

Idle Noise 78.5 dB(A) exterior

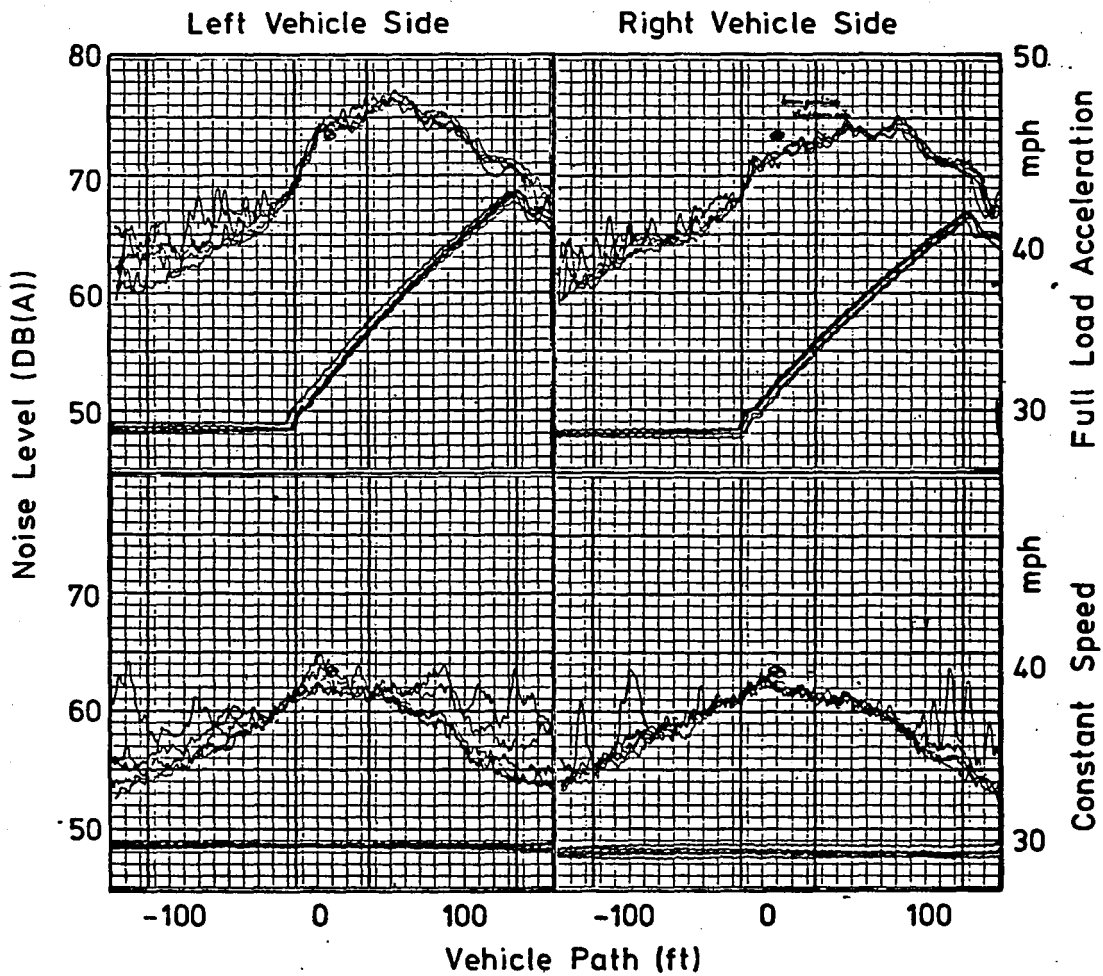

NOISE EMISSION

GOLF GLD NO. 2 WITH 50 HP PRODUCTION DIESEL

Idle Noise 83 dB(A) exterior

55.5 dB(A) interior

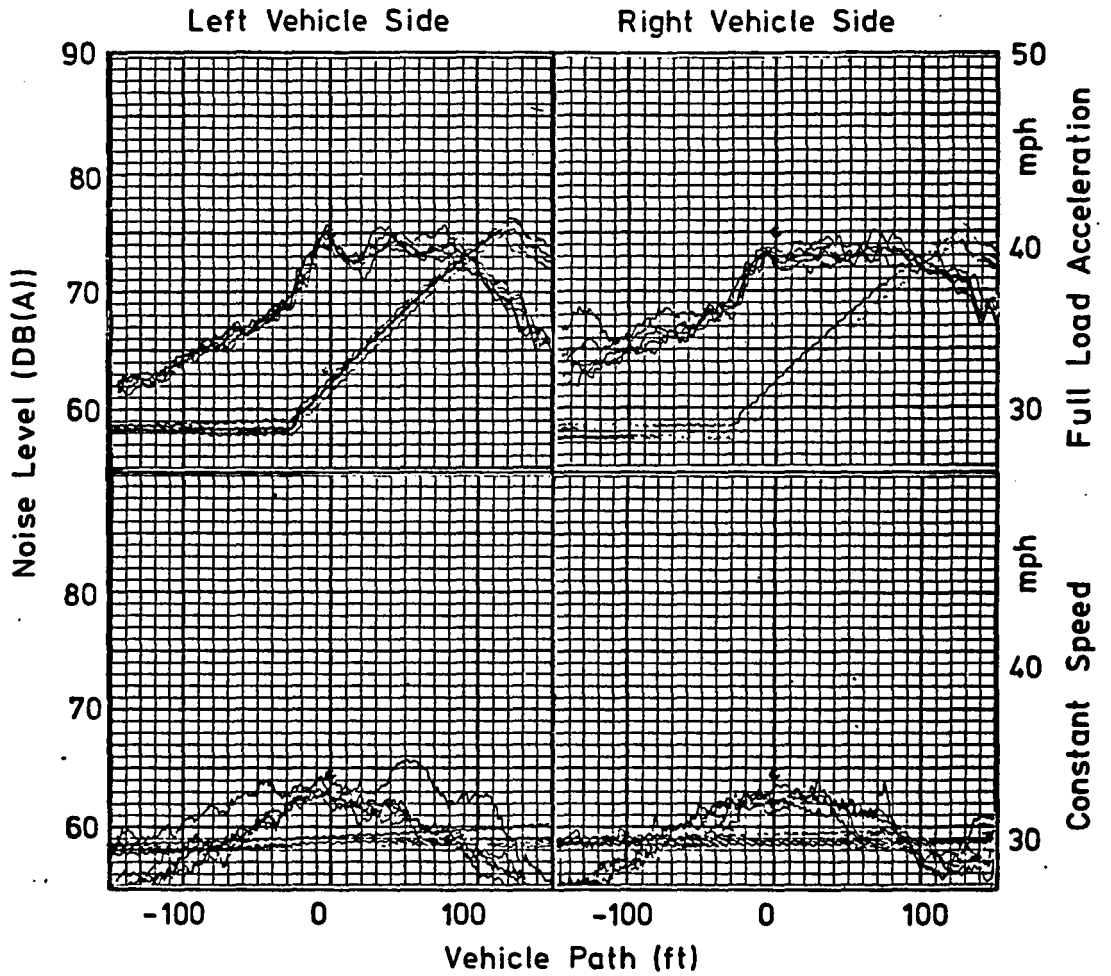

NOISE EMISSION

GOLF GLD NO. 3 WITH 50 HP PRODUCTION DIESEL
on wet surface.

Idle Noise 80 dB(A) exterior
54 dB(A) interior

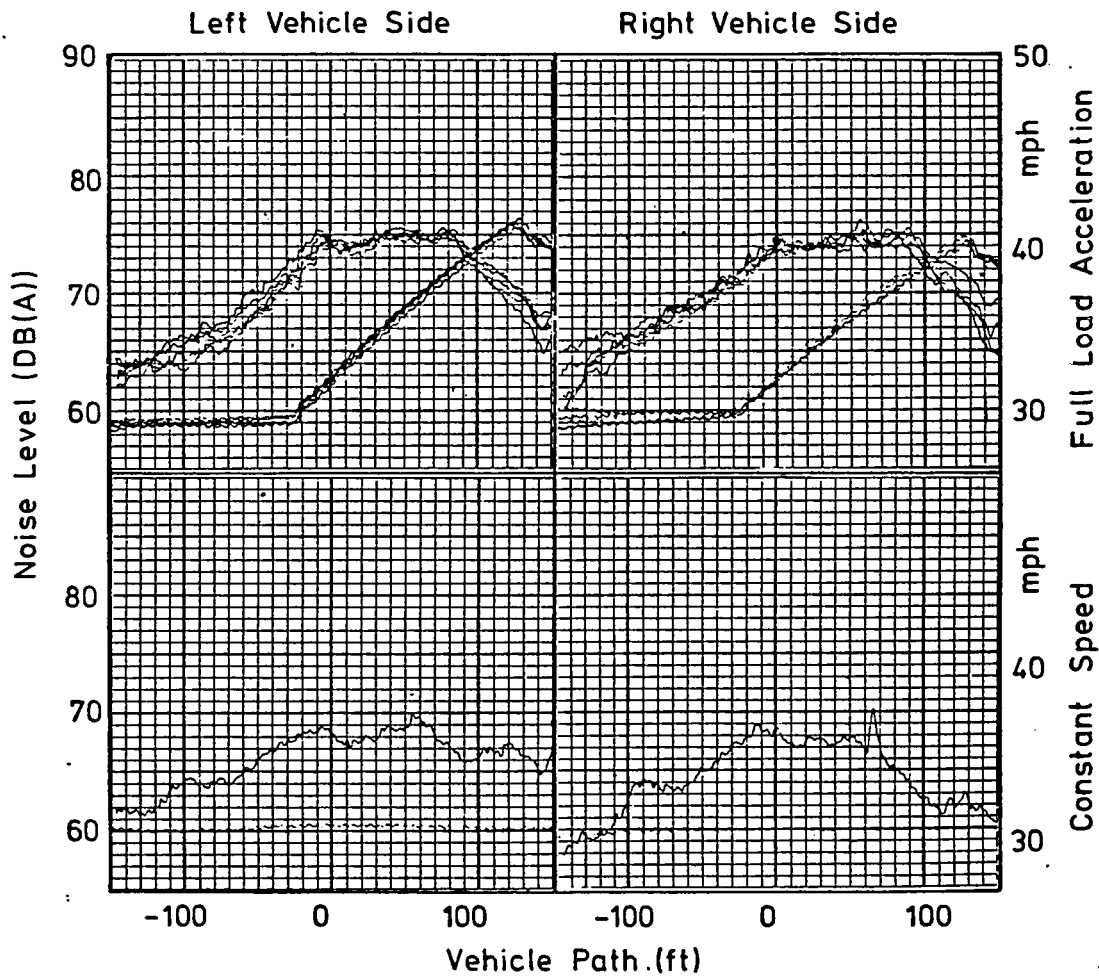

NOISE EMISSION

GOLF LD WITH 70 HP TURBOCHARGED DIESEL

Gunfire background

Idle Noise 79.5 dB(A) exterior

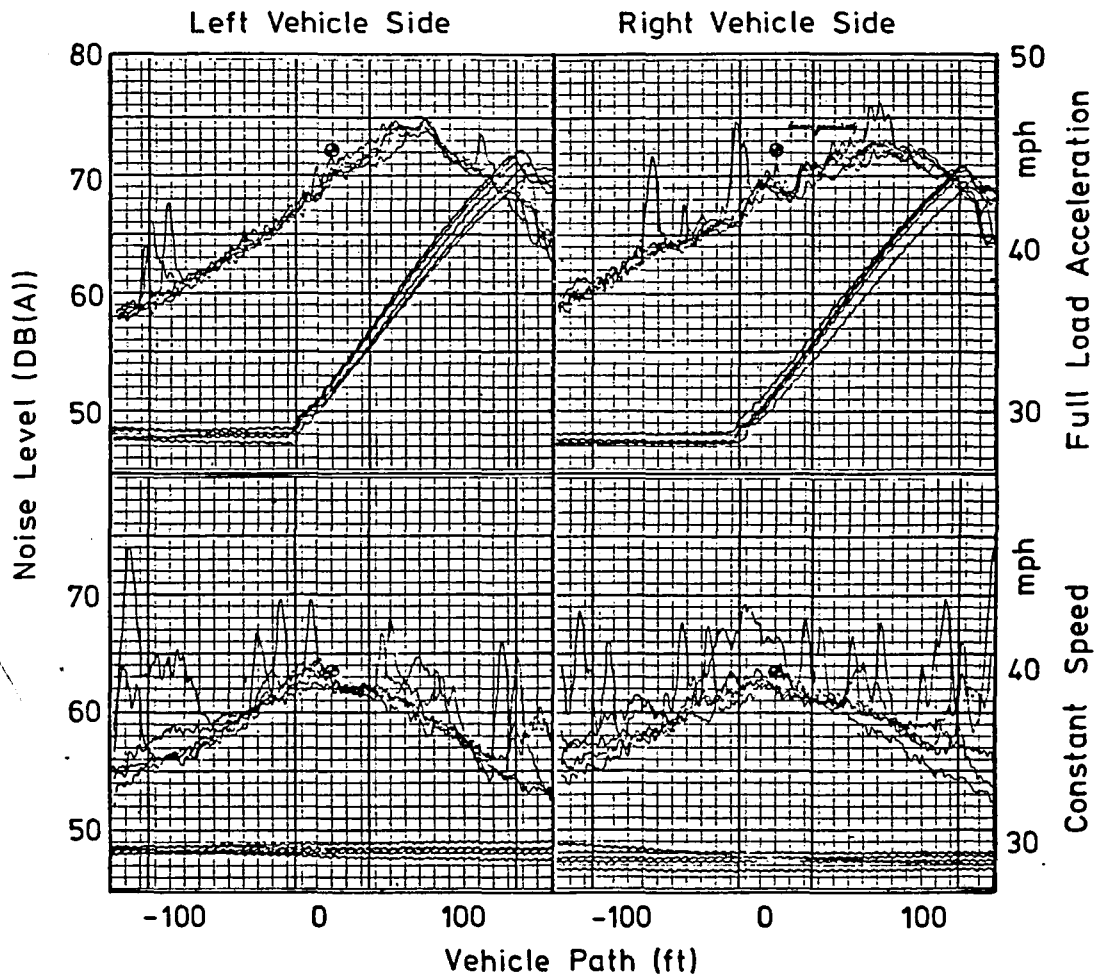

NOISE EMISSION

GOLF GLD WITH 70 HP TURBOCHARGED DIESEL

Gunfire background

Idle Noise 79.5 dB(A) exterior

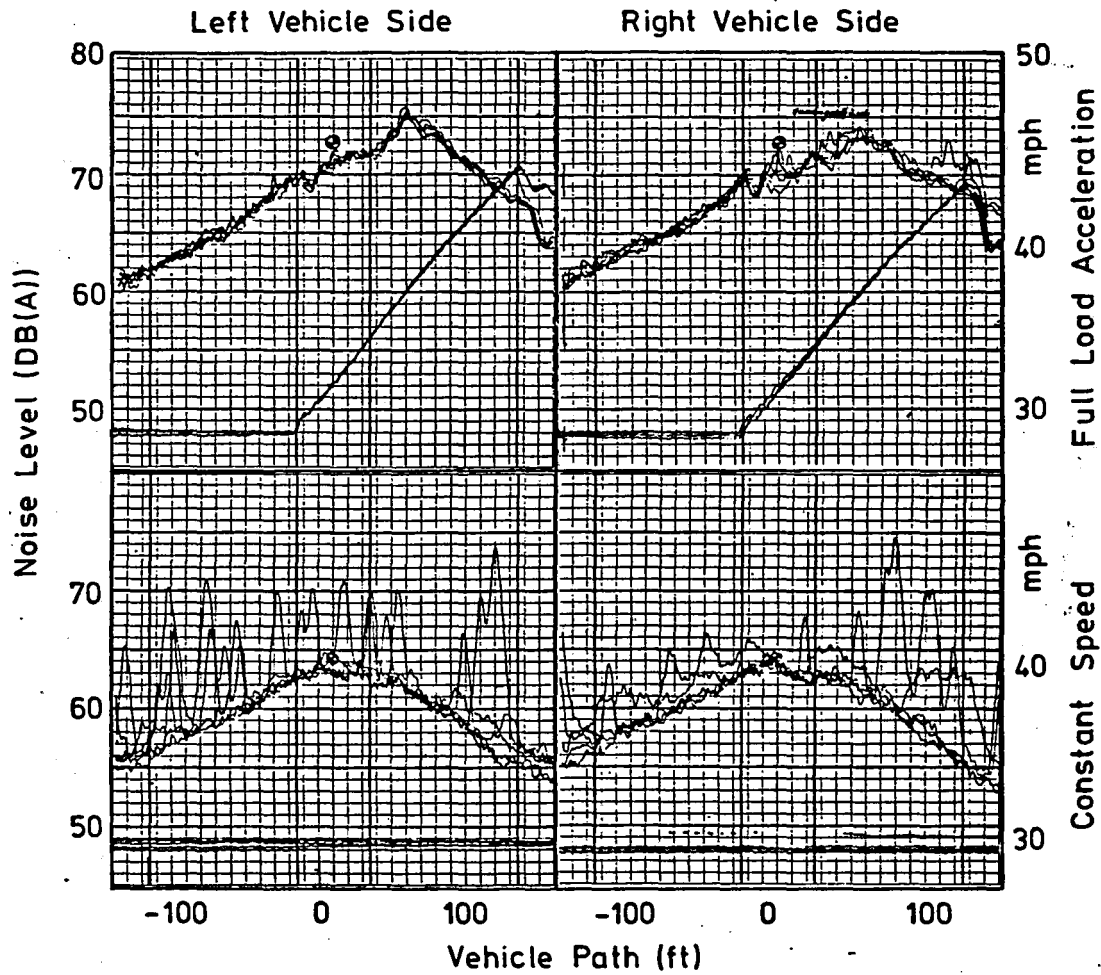

NOISE EMISSION

RABBIT D WITH 70 HP TURBOCHARGED DIESEL
30 mph cruise in 2 nd. gear.

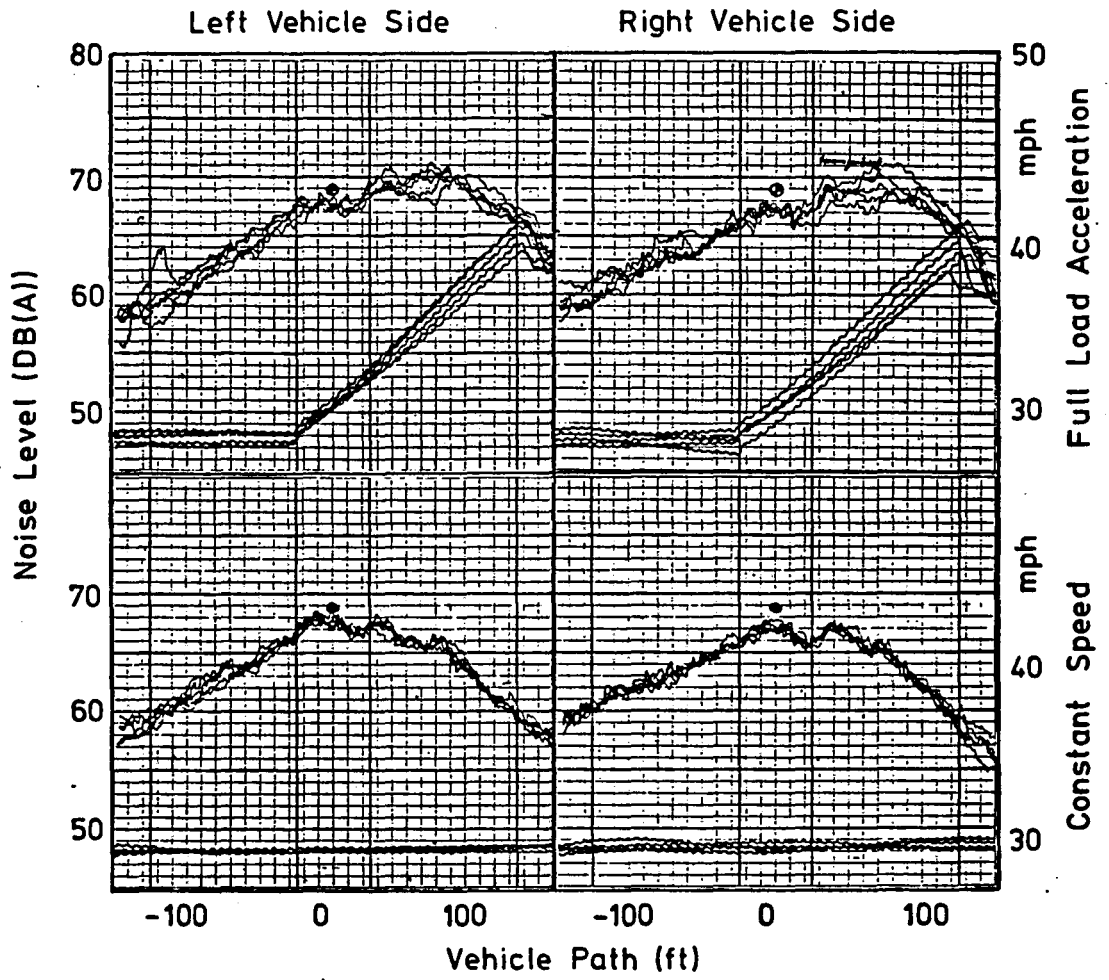

NOISE EMISSION

IRVW WITH 70 HP TURBOCHARGED DIESEL

Idle Noise 74 dB(A) exterior

56 dB(A) interior

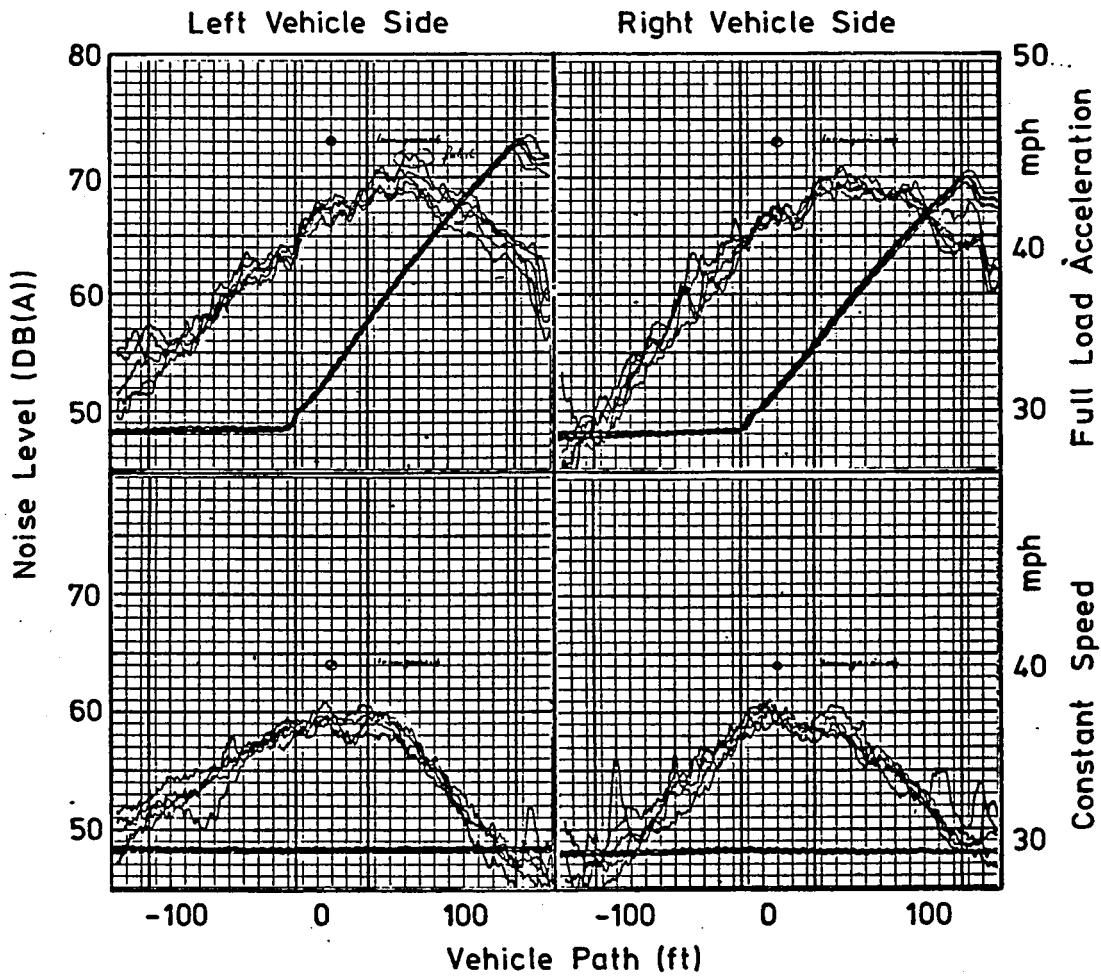

NOISE EMISSION

GOLF GLD WITH 50 HP N.A. E.G.R. DIESEL

Idle Noise 73 dB(A) exterior

51 dB(A) interior

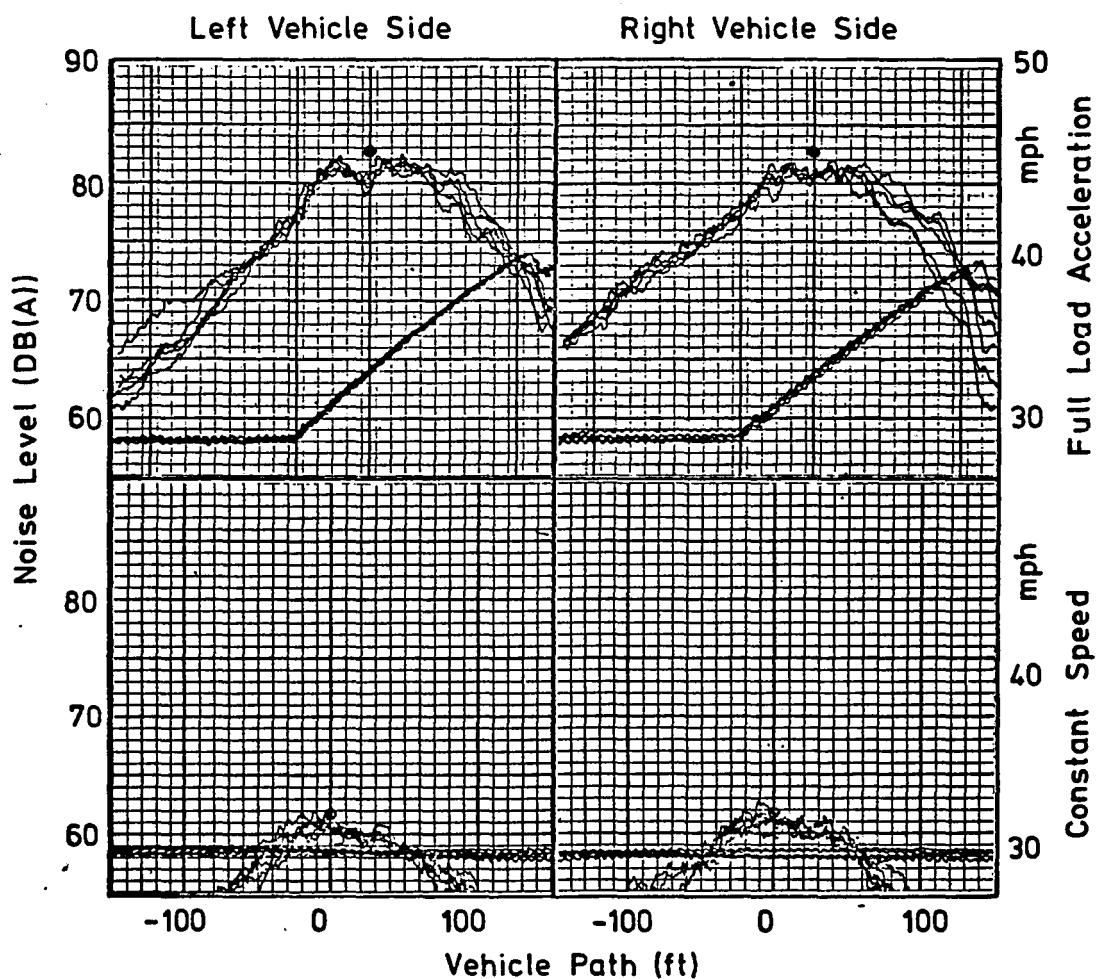

NOISE EMISSION

GOLF GLD WITH 70 HP TC E.G.R. DIESEL

Idle Noise 76 dB(A) exterior

54 dB(A) interior

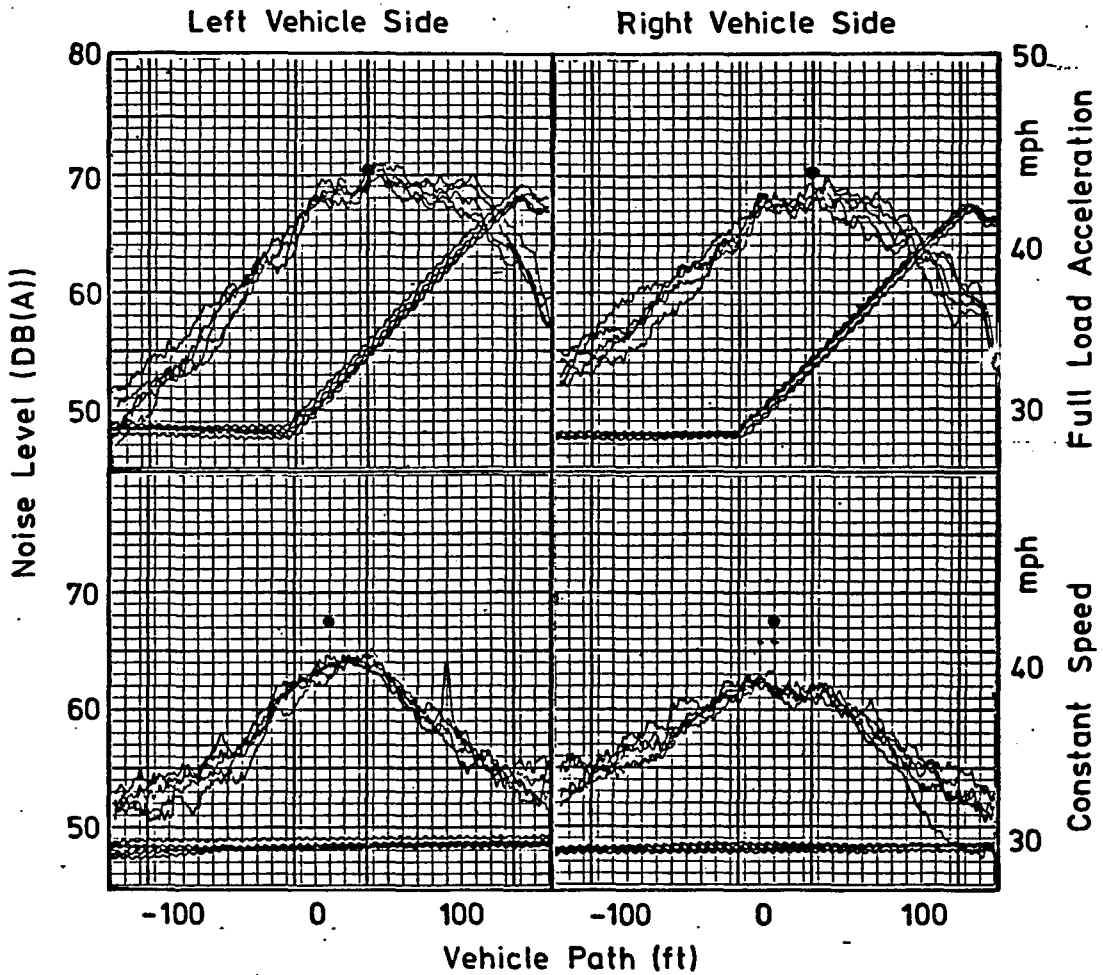

NOISE EMISSION

GOLF GLD WITH 70 HP TC H₂O DIESEL

Idle Noise 81 dB(A) exterior

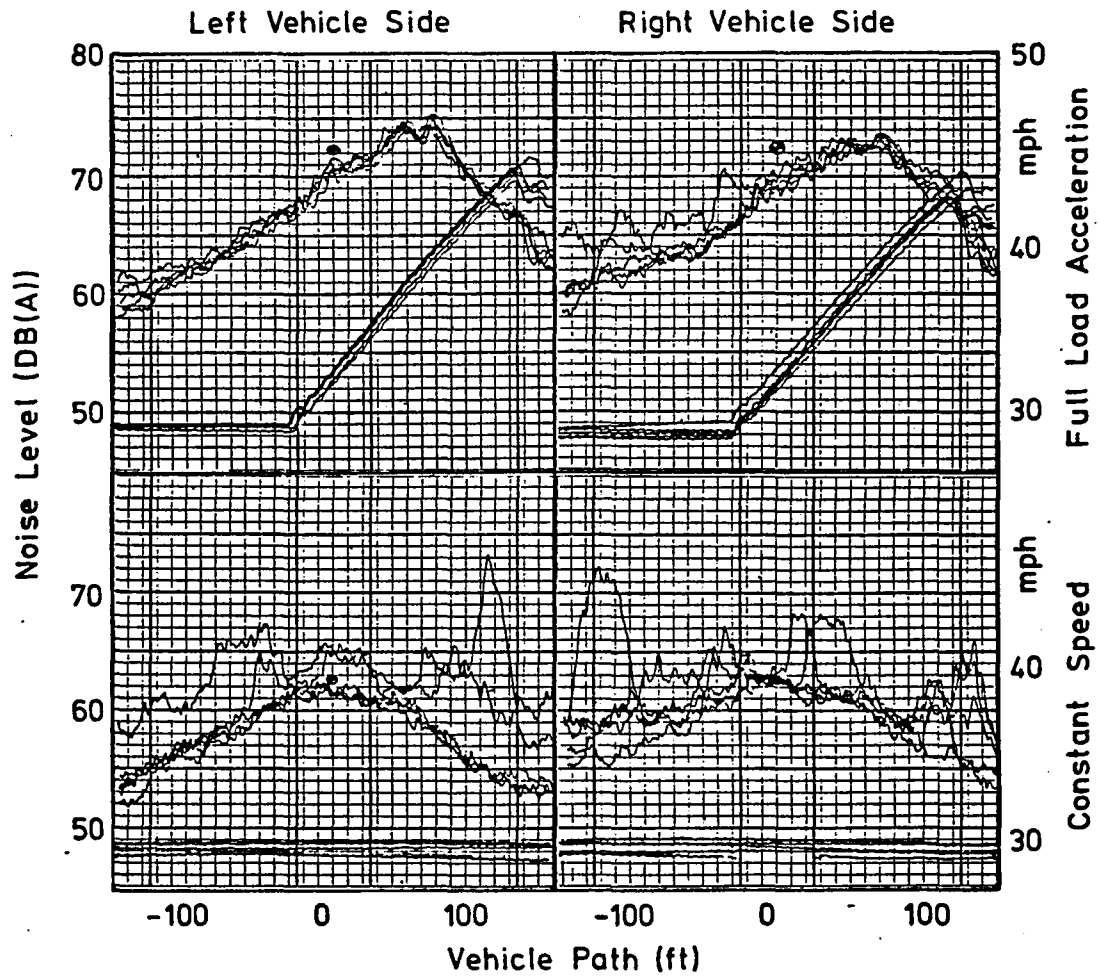

NOISE EMISSION

AUDI 100 WITH 5 CYLINDER N.A. DIESEL

Idle Noise 75 dB(A) exterior
55.5 dB(A) interior

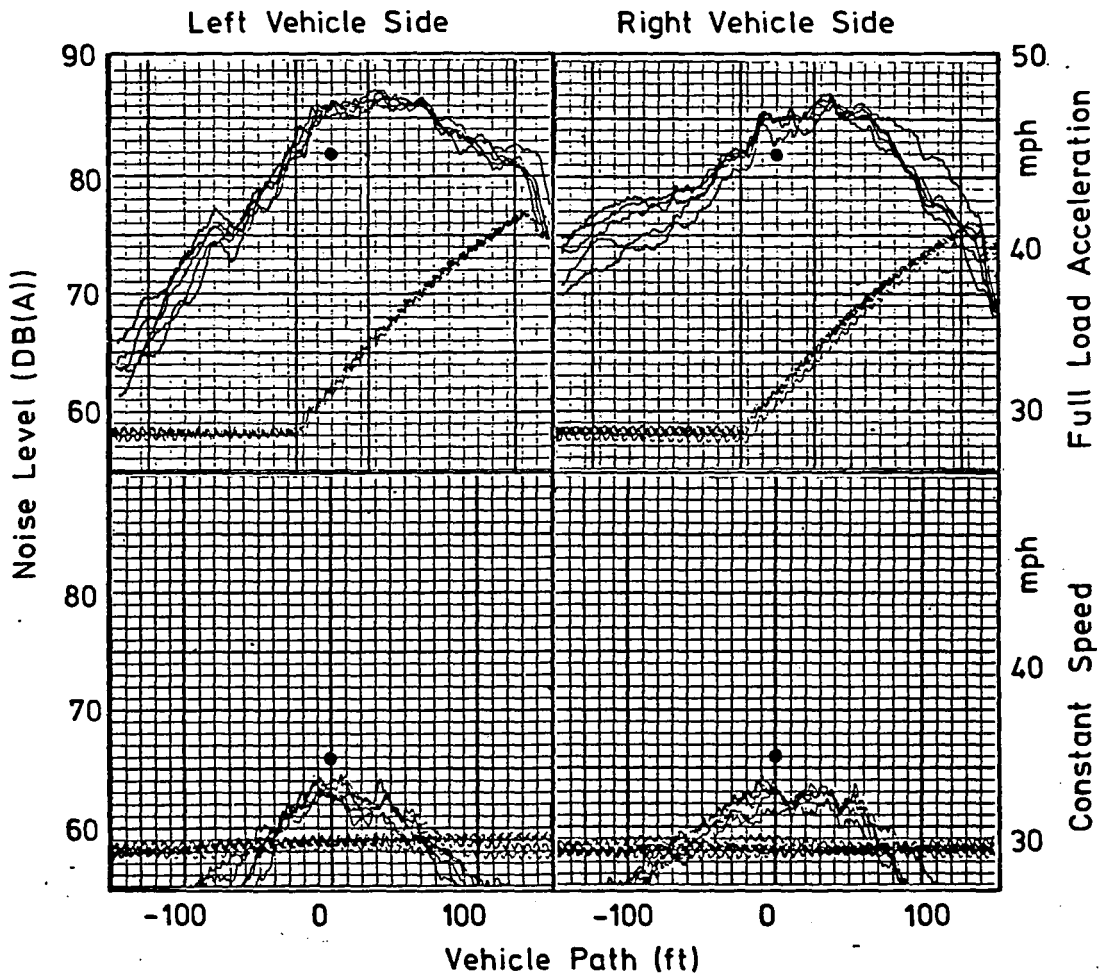

NOISE EMISSION

GOLF WITH 50 HP GASOLINE ENGINE

Idle Noise 74 dB(A) exterior

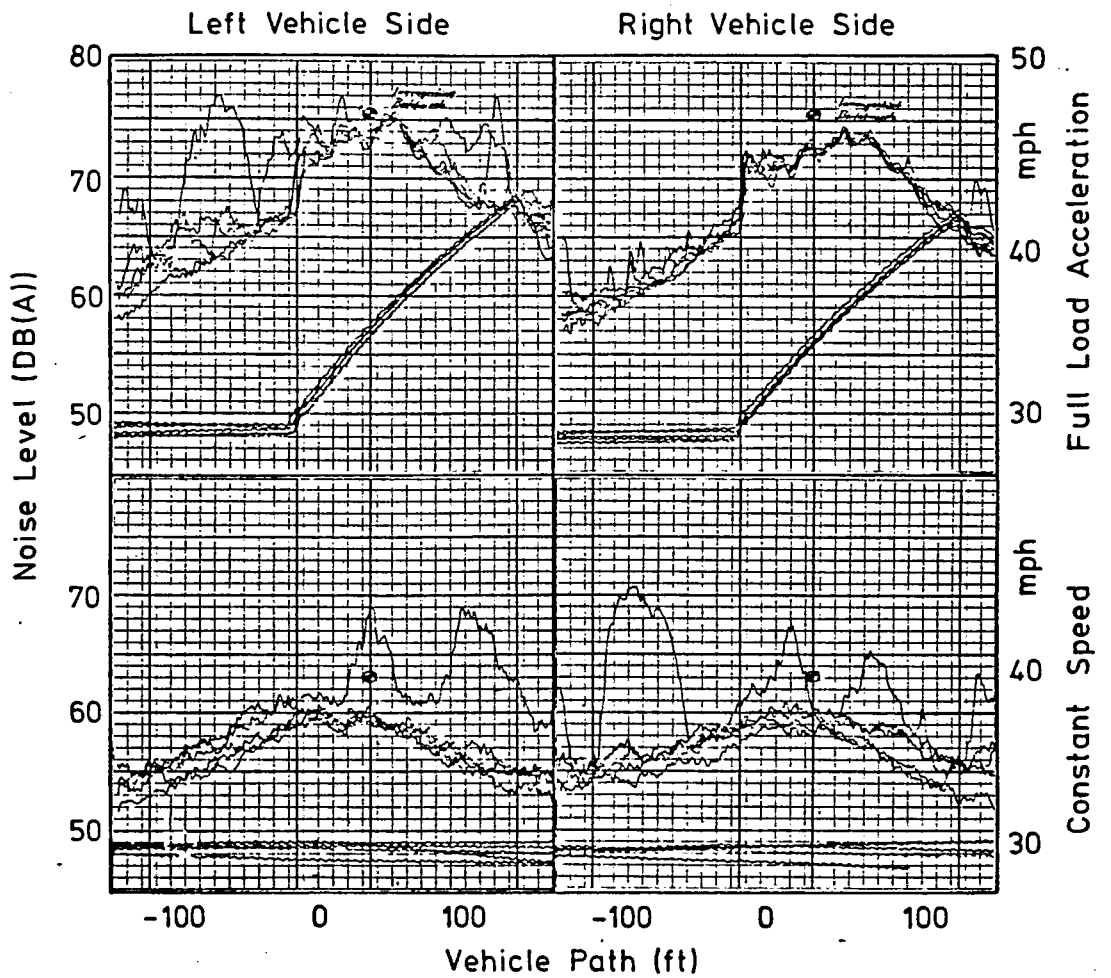

NOISE EMISSION

GOLF L WITH 50 HP GASOLINE ENGINE

Idle Noise 71 dB(A) exterior

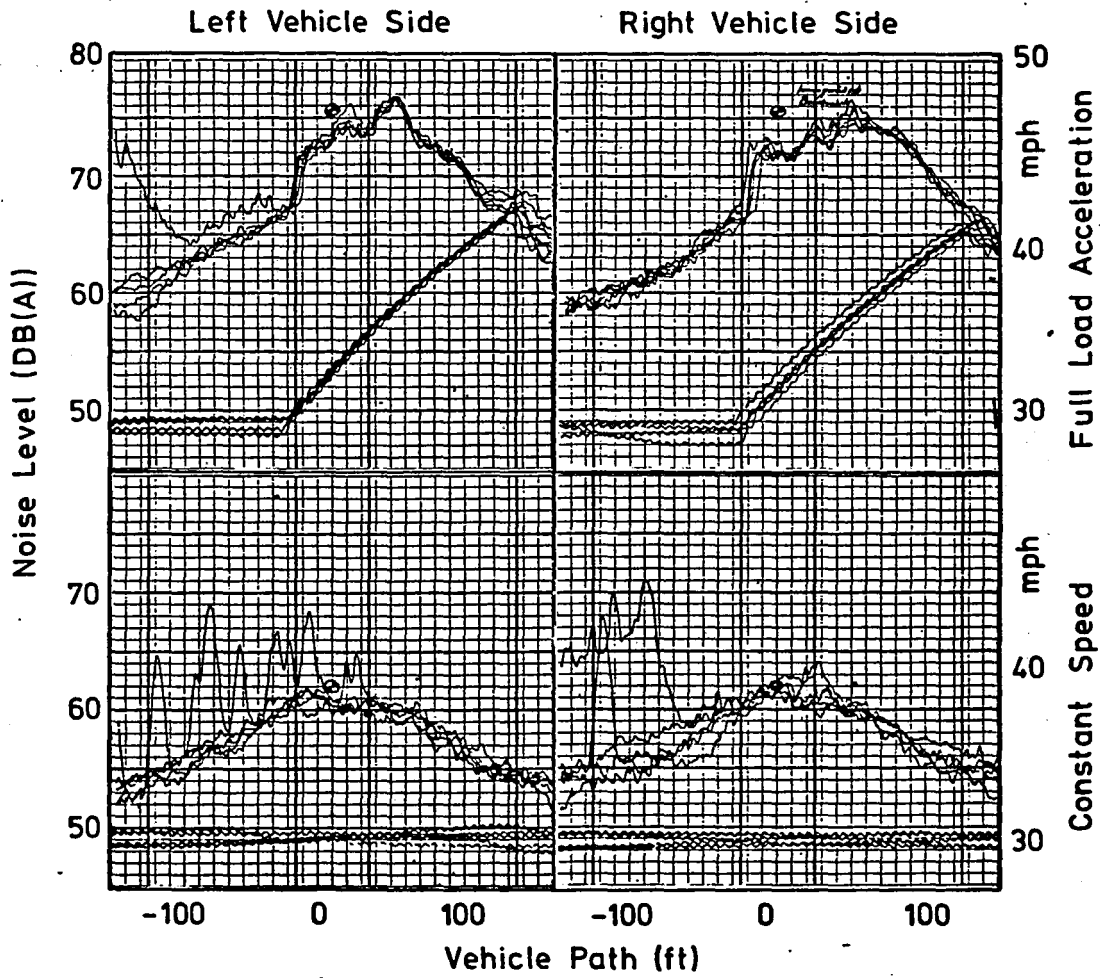

NOISE EMISSION

GOLF GL NO. 1 WITH 50 HP GASOLINE ENGINE

Idle Noise 76 dB(A) exterior

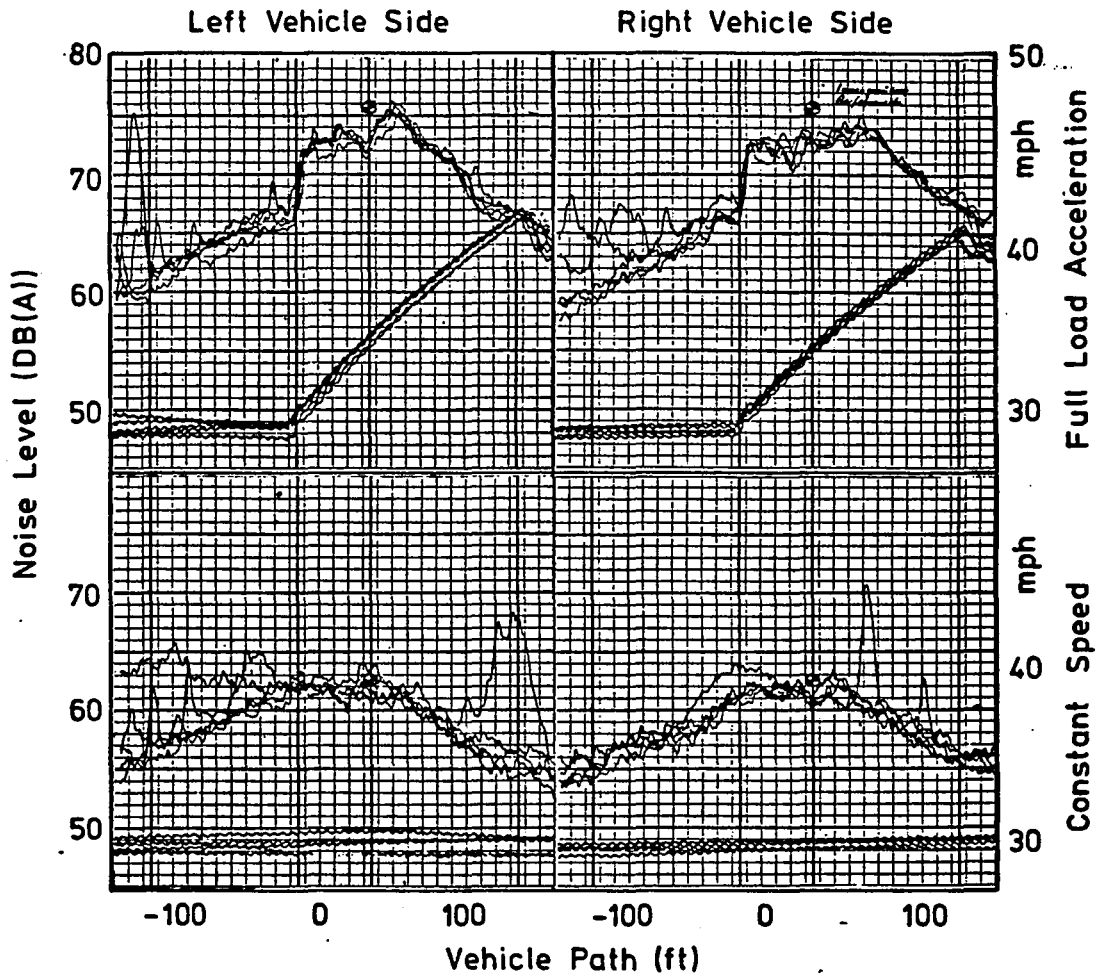

NOISE EMISSION

GOLF GL NO. 2 WITH 50 HP GASOLINE ENGINE

Idle Noise 75 dB(A) exterior

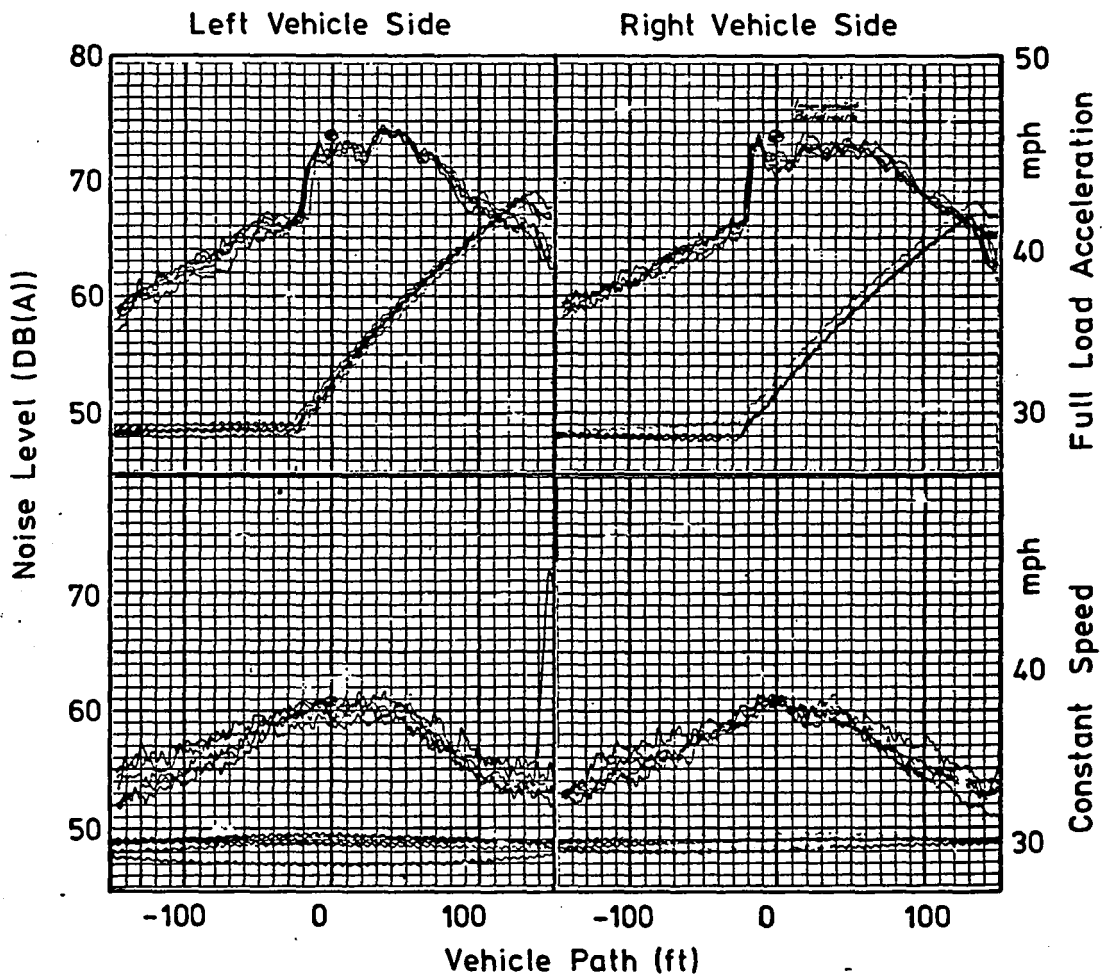

NOISE EMISSION

GOLF GL NO. 3 WITH 50 HP GASOLINE ENGINE

Idle Noise 75 dB(A) exterior

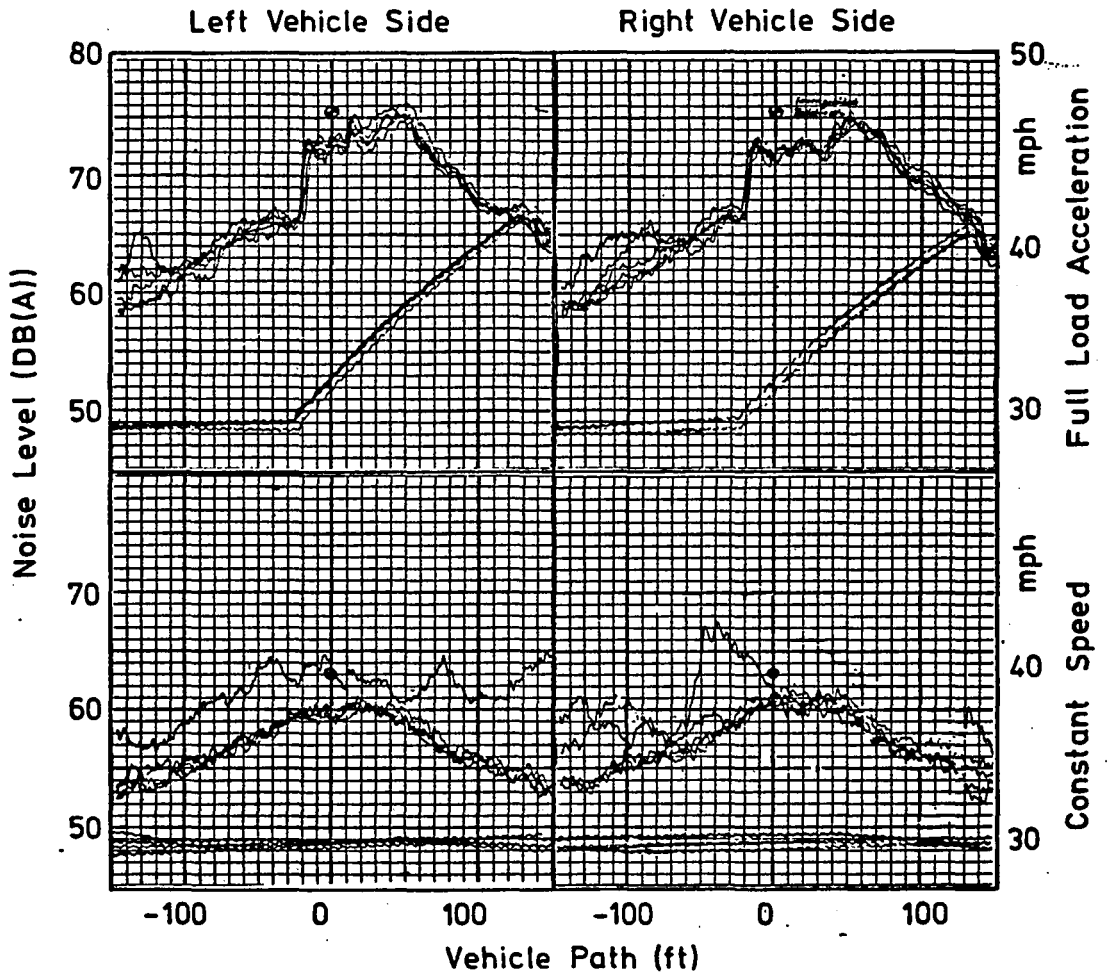

NOISE EMISSION

OPEL D WITH 60 HP PRODUCTION DIESEL

Idle Noise 83 dB(A) exterior

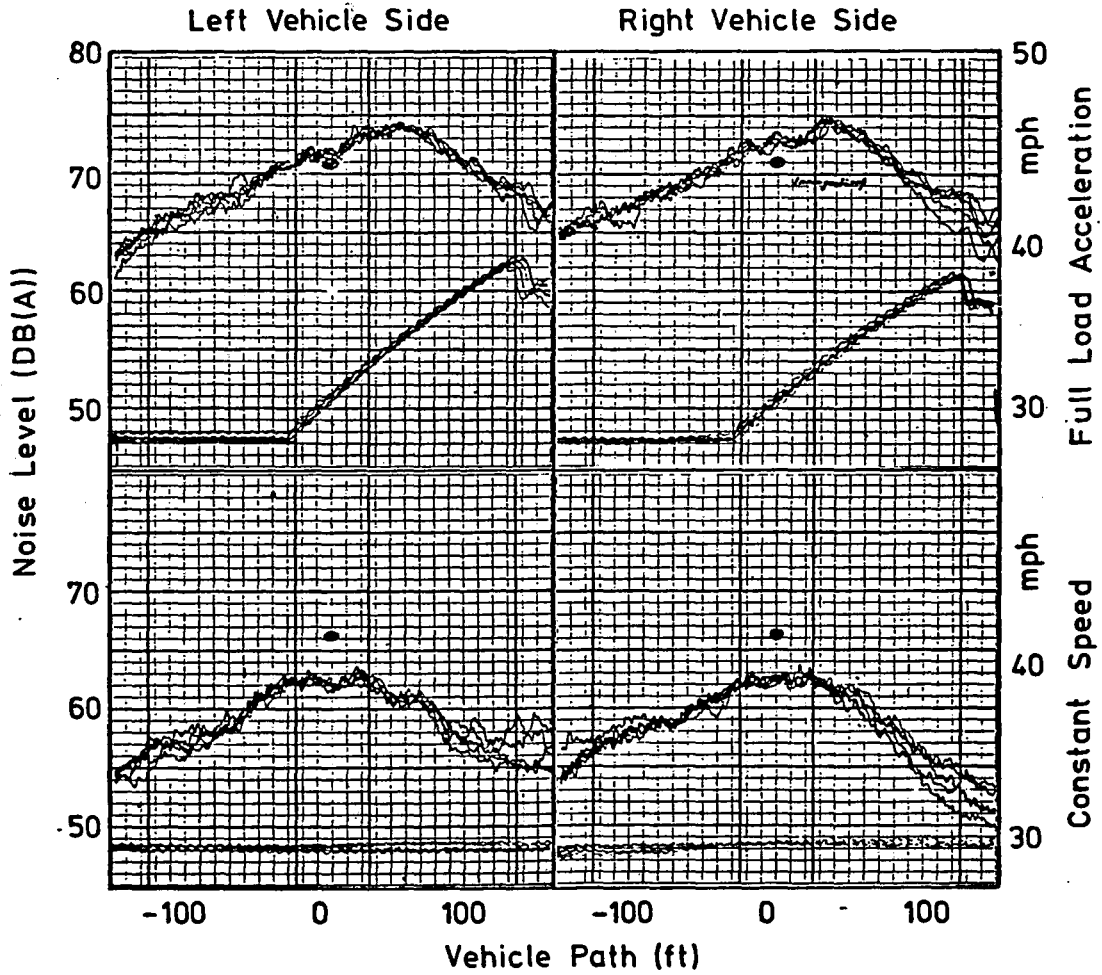

NOISE EMISSION

PEUGEOT 504 WITH 65 HP PRODUCTION DIESEL

Idle Noise 80 dB(A) exterior

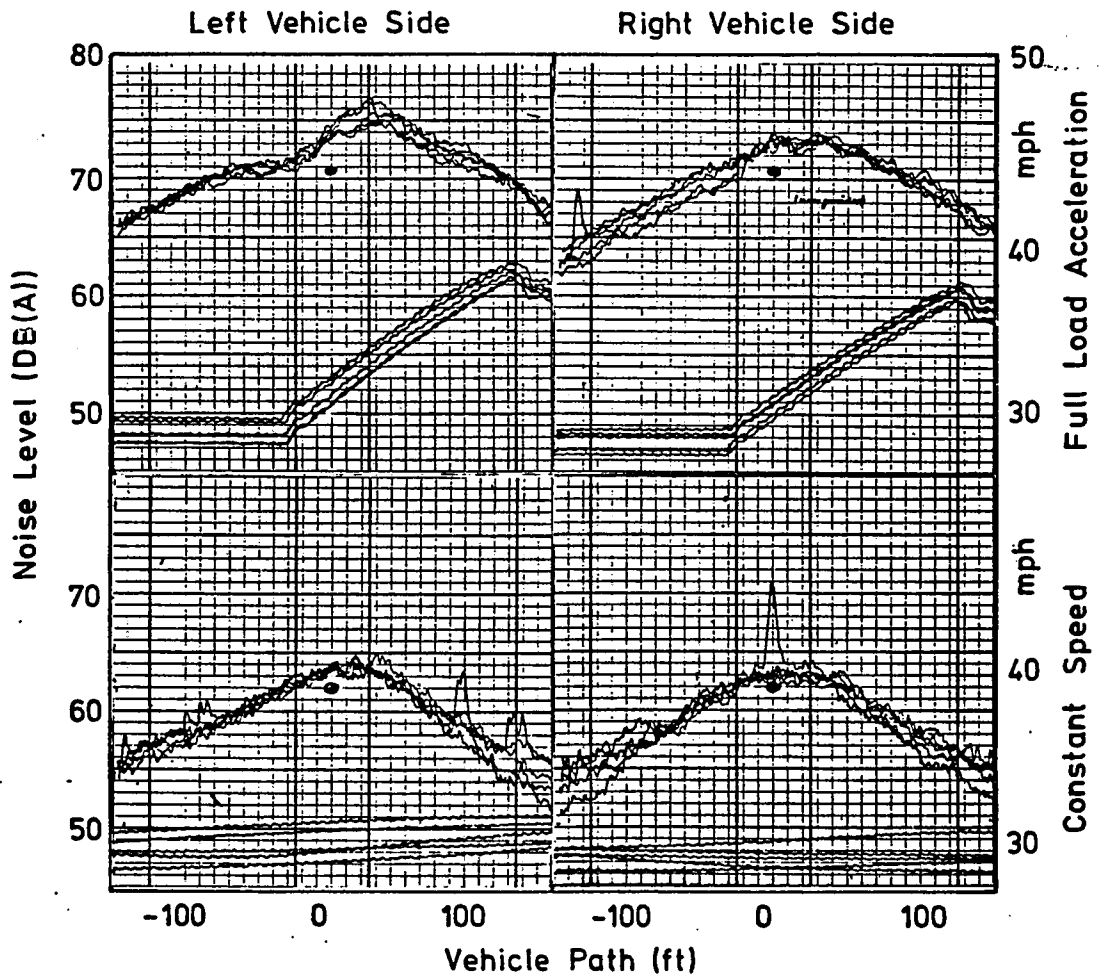

NOISE EMISSION

MERCEDES 300 D WITH 80 HP PRODUCTION DIESEL
Automatic Transmission

Idle Noise 81 dB(A) exterior

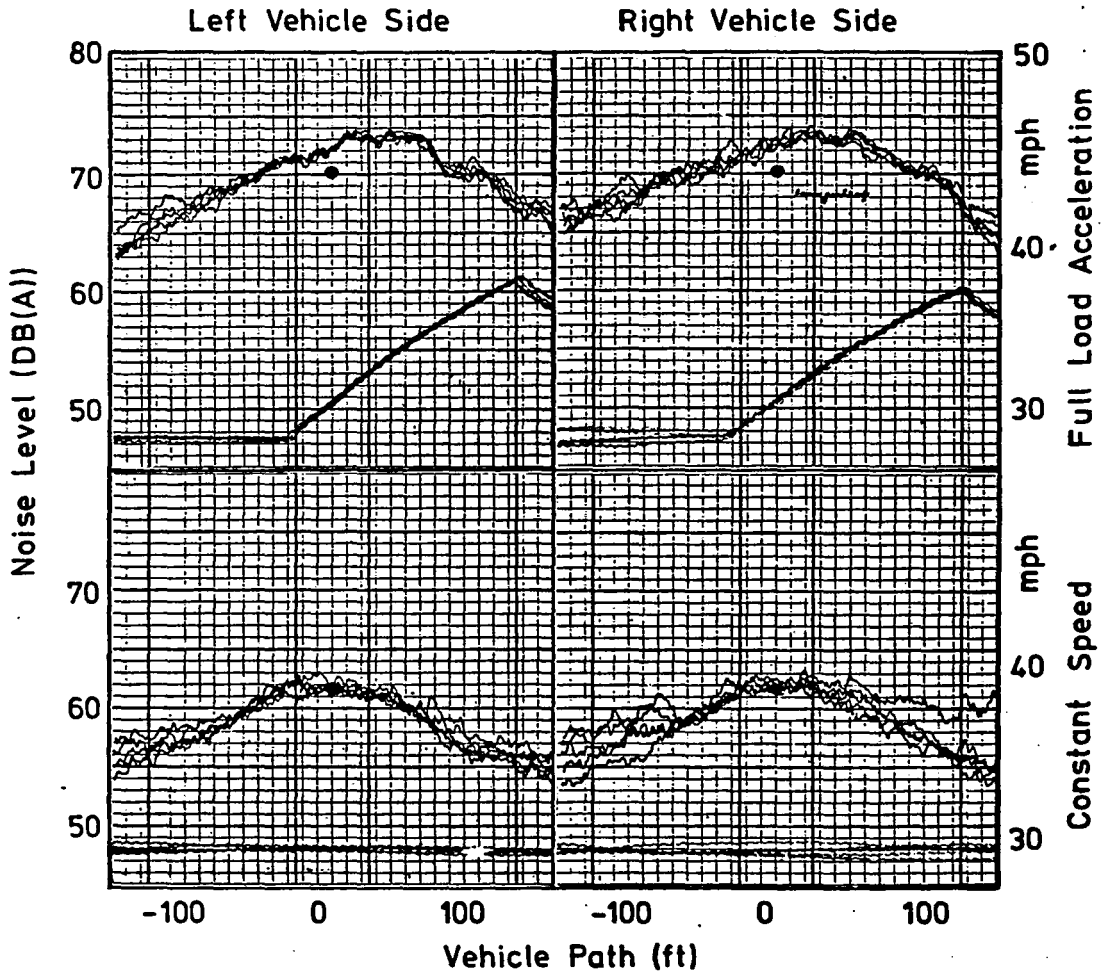

APPENDIX B
REPORT OF NEW TECHNOLOGY

The work performed under this contract, while leading to no new inventions has provided a detailed characterization of the engines studied with emphasis on fuel economy, emissions and driveability.